

911 SC

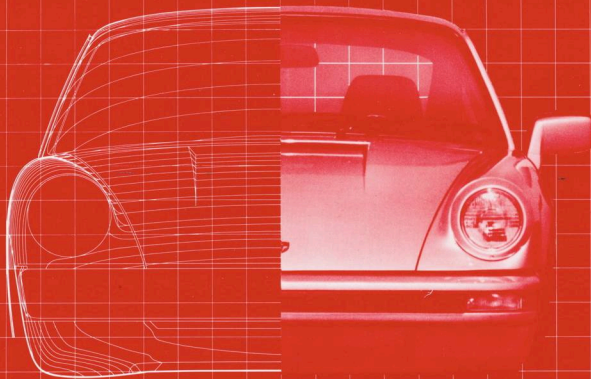

PORSCHE



Porsche. The Sports Car Specialist.

In the country that spawned many of the world's classic marques, Porsche stands alone as the only auto maker totally committed to the sports car. With all the facilities, imagination and creativity of the famous Porsche Development Center at Weissach. With all of the knowledge gained through generations of building one racing champion after another. And with all of the effort and enthusiasm housed in an automobile plant where hand-craftsmanship survives side by side with some of the most modern precision manufacturing techniques.



For more than three decades, Porsche engineers have chosen to produce only sports cars, honed through years of racing experience. By devoting themselves to the one type of car they know best and love most, the men of Porsche have created the world's largest independent manufacturer of sports cars. Today, Porsche offers the most versatile range of cars in its history. The classic Porsche formula, air cooled and rear-engined, is represented by the powerful 911SC.

Porsche has always limited its official participation in auto sports to those events in which knowledge gleaned will translate into data useful in the creation of superb road cars. Through thirty years of racing and rallying, Porsche has achieved an undisputed standing

as the most successful make in international auto sports.

Every Porsche, whether for the road or for the track, is built with a unique combination of performance and extreme reliability and endurance. They are the product of Weissach, one of the most modern and efficient research centers in the automobile industry. Staffed by designers, engineers, and stylists who have to their credit a host of world record cars.

The 911SC is the direct outgrowth of invaluable know-how derived from tough, highly competitive sporting events. It is a Porsche that has long set the standard among sports cars worldwide for performance, tenacity and reliability.



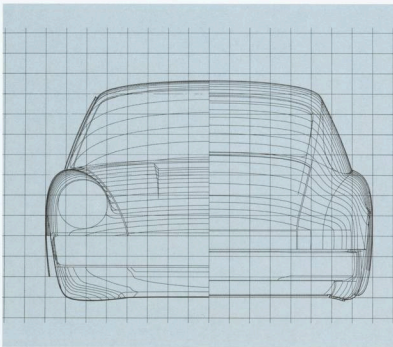

A Shape Makes History.

Porsche unveiled the shape of things to come nearly two decades ago, at the 1963 International Automobile Exposition at Frankfurt am Main.

Inherently aerodynamic, the body of the 911 quickly gained instant acclaim from driving enthusiasts. Its low drag aided the car's performance, gave it astounding insensitivity to crosswinds, and added the extra bonus of fuel economy.

Today, the 911SC lines are much as they were at the birth of this series in 1963. Yet still ahead of their time. And still representative of the Porsche commitment to emphasize design and engineering over mere fashion.

But for Porsche, time never stands still. And

throughout its 16-year life, the 911 series has received a continuing flow of improvements from the rich stream of data flowing from Porsche participation in racing and rallying. At the same time, the 911s have provided the technical foundation for the racing and rallye cars that have made Porsche one of the most successful marques in international motor sports.

Long-distance events, a principal area of Porsche participation, demand cars that combine optimal performance, maximum reliability, and minimal maintenance needs. These are features that provide meaningful advantages in everyday driving as well. The knowledge and experience gained in long-distance racing have been incorporated in the 911SC, fulfilling the classic Porsche concept of continuing interaction between racing and production cars.







Porsche 911SC: The Classic Sports Car Evolves.

The classic 911 line finds its culmination in the 911SC, powered by its 3-liter, 172 hp engine.

Power of this sort, while rarely if ever useful in highway driving, is meaningful in terms of the power available at low and medium speeds for safe passing and merging.

To match its powerful 3-liter engine, the 911SC has been fitted in the rear with wide, high-speed 215/60VR15 belted radial-ply tires beneath the deeply flared rear fenders. In front, the 911SC is fitted with 185/70VR15 tires. Optional forged light alloy wheels available for the 911SC have a larger 16-inch diameter, and carry the ultra-low profile radial tires originally introduced on the Turbo Carrera. These may well provide the finest road grip now available in a sports car tire.

For 1981, powerful quartz halogen headlamps have been incorporated in the 911SC. And the car is protected front and rear by unique Porsche bumpers. These are designed to help protect vital running lights from damage in minor accidents. Made of light yet rigid aluminum, the bumpers feature protective rubber moldings and bumperettes at the rear. Hydraulic energy absorbers permit them to move back in moderate impact of up to 5 mph, then restore themselves to their original position.

Specifications, options, and standard equipment subject to change without notice.

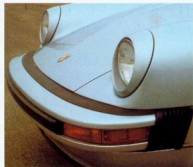
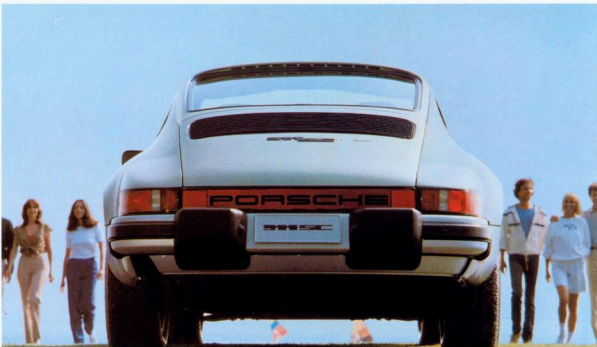

Porsche 911SC Targa. The Wind in Your Hair.

Here are all the comforts of the 911SC Coupé, with the additional pleasure of driving beneath a wide expanse of sky.

The light yet rigid folding roof removes easily and quickly stows away inside the car. The matte black, stainless steel, integrated roll bar provides rigidity and added safety.

The Targa roof requires no special maintenance. It is tightly sealed to prevent drafts and leaks in the rain or in a car wash. The fixed rear window has tinted glass and a two-stage electric defroster as standard equipment. For added security, the front trunk and the glove compartment can be locked, so that the Targa may be left open when parked.

Specifications, options, and standard equipment subject to change without notice.



Inside Porsche 911SC: Sumptuous Styling at Speed.

Improvements and refinements continue to raise the level of luxury offered in the interior of the 911SC. It is outfitted with exquisite, color-coordinated fabrics and materials that are as beautiful as they are durable.

In addition to new Berber fabrics and special leather upholstery, the 911SC offers its owners a host of practical amenities.

For an even more sporty look, there's a 3-spoke leather covered steering wheel just 38 cm in diameter. Drivers traveling alone will particularly appreciate the standard electric windows that eliminate the need for an uncomfortably long stretch when opening the co-driver's window. A practical center console offers handy storage for small change, odds-and-ends, and assorted necessities. The console also houses the air conditioning controls, as well as the blower and temperature switches.

Porsche seats are built for the long haul. They are adjustable for leg length and recline to the optimum position for drivers of virtually any build. And for 1981, there are new optional sport seats in all-leather or with Berber cloth inlays.

The driver of the 911SC receives a continuous flow of information on his car's functions from a highly legible bank of instruments housed beneath non-glare covers. The rack and pinion steering system is both sure and precise. And both the driver and co-driver receive a steady stream of fresh air from the efficient ventilation system, with precise control over heater temperature for comfortable cold-weather driving.

Specifications, options, and standard equipment subject to change without notice.



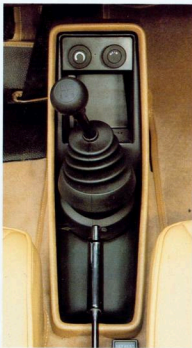

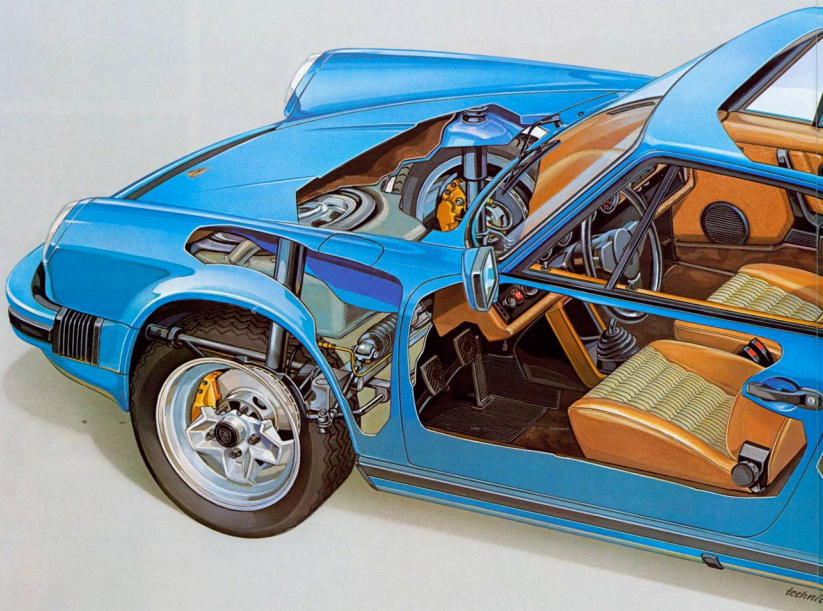

technic

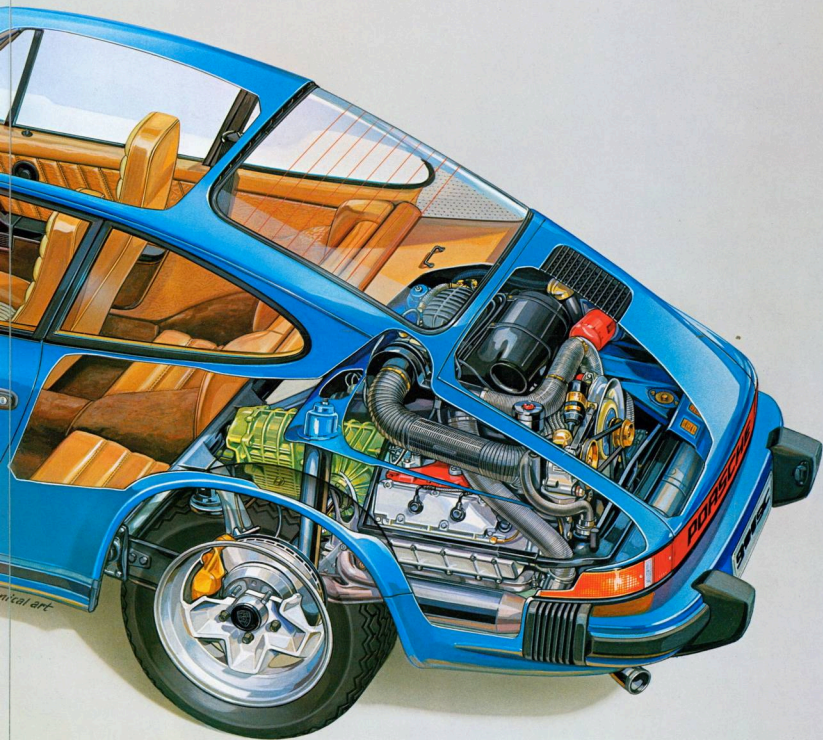

digital art





Powerplant of the 911SC: Heir to World Champions.

Built for high-endurance performance and the kind of stresses normally encountered only on the race track, the air-cooled, 3-liter engine of the 911SC traces its lineage to similar engines that powered many of Porsche's World Champions. As such, it is capable of sustaining maximum effort over long periods of time.

The rear-mounted, air-cooled power plant, with its horizontally opposed 6 cylinders, overhead cam, and inclined overhead valves in hemispherical combustion chambers, operates at a compression ratio of just 9.3:1.

The new tubular oil cooler, along with a host of other features, contributes to the ability of the engine to shrug off hour after hour of grueling high-speed driving on the race track. The precision-balanced forged steel



crankshaft, for example, is supported by eight main bearings. Dry sump lubrication, a system normally reserved for racing cars, maintains a steady flow of cooled oil to all vital points, even when driving through steep curves with high lateral forces.

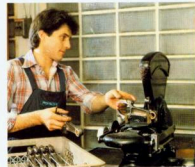
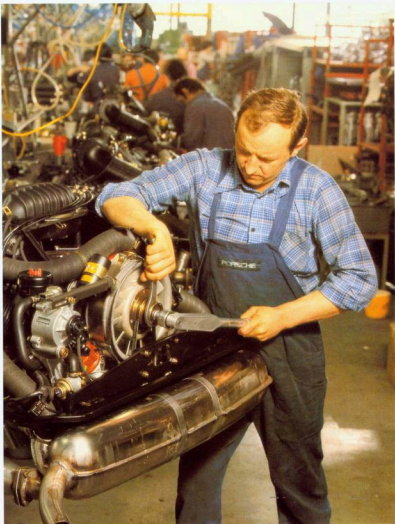

The large cylinder bore of the 911SC engine has made possible an output of 172 SAE net horsepower at 5500 rpm. This reserve of power gives the engine its flexibility and pulling power from low and medium speeds, making for safe, quick passing and merging.

For fast all-weather starting, the 911SC uses the proven CIS fuel injection system and maintenance-free breakerless transistorized ignition. The CIS fuel injection system provides a more efficient burning of the fuel for a combination of economy (Ⓢ estimated mpg, 26 estimated highway mpg)* and lower exhaust emission.

*1980 EPA estimates. Compare this estimate to the "estimated mpg" of other cars. Your mileage may vary with speed, weather and trip length. Highway mileage will probably be less. 1981 EPA figures not available at press time.

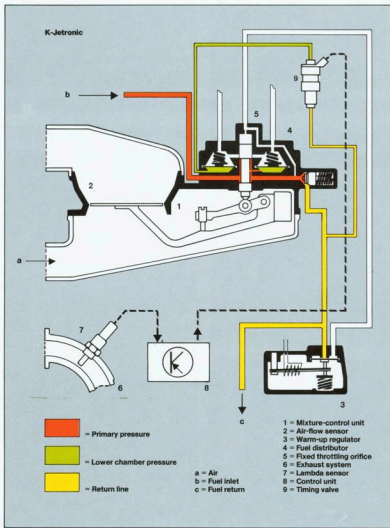

Every 911SC engine is run for a full hour on the test bench to prove that it is capable of meeting Porsche's expectations. After it is mounted in the car, the vehicle is run for ten minutes on a chassis dynamometer, and then over a 20-mile road test during which an experienced driver checks 180 different items. Only after all this, is the 911SC ready for delivery to its owner.



Shifting the 911SC:
Smooth,
Precise, Sporting.

Proven in years of use over a succession of 911 models, the locking synchromesh transmission makes it possible to operate the 911SC in the optimum rpm range at all speeds. Like its predecessors, the 1981 911SC is equipped with a five-speed transmission as standard equipment. The "long" fifth gear delivers the same top speed as previous models at 4.5% lower rpm's. At all times, the driver has at his command the right gear ratio for every situation. To save weight, the transmission housing is made of lightweight aluminum.

Specifications, options, and standard equipment subject to change without notice.

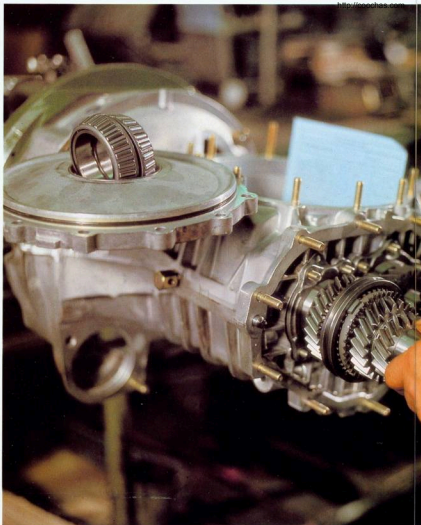
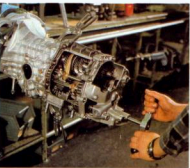
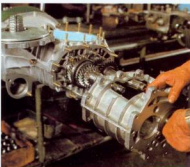
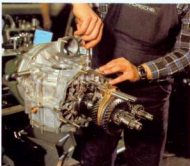

To stand up under the high torque output of the 3-liter engine, the 911SC utilizes a strong differential, identical to that of the Turbo and the 928. A limited slip differential with a 40% locking effect is available as an option.

Yet another drive-train refinement of the 911SC is a cushioned clutch disc that smooths the engagement of the spring-assisted clutch action.

Transmission Diagram

Power 11.5 hp/kwh 5.85 P - Number of teeth 3.07. The gear 2.76/3.07/3.31 - 2.25/3.07/3.31

Remark: This diagram shows gear ratios based on a standard gearbox which allows high revs. However, due to the design there can occur shifts in the gear and/or in the clutch action. The gear ratio and the number of teeth can vary without notice.

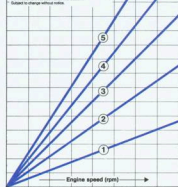

Acceleration Curve

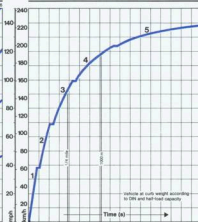

Full-power Curve

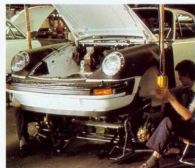
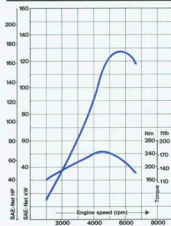



Chassis of the 911SC: Even "Faster" Than the Engine.

A sense of safety and responsibility has always dictated that the chassis of every Porsche be conceived in engineering terms as "faster" than the engine.

In the 911SC, the front wheels are individually suspended on cross arms, while the rear wheels are

individually suspended on light alloy diagonal arms. Carrying through a concept pioneered by Professor Ferdinand Porsche, the 911SC uses compact, efficient torsion bars to spring all four wheels. These springs are closely integrated with the suspension, which guides the front wheels with shock absorber struts and the rear wheels by means of rigid, yet light and corrosion resistant light alloy diagonal arms.

The suspension geometry has been carefully calculated to ensure that each of the tires will run at the

correct camber angles for optimum cornering through the full range of loads the 911SC may carry. Long-travel tubular shock absorbers play a role in this design. And the 911SC is tuned to the demands of sports car drivers through the addition of anti-roll stabilizer bars, 20 mm diameter in front, 18 mm diameter in the rear.

To preserve the balance of the 911SC chassis, the car has been fitted with rear wheels and tires that are wider than those in front. Standard in front are 185/70 VR15 tires on 6-inch pressure cast alloy rims. The rear wheels carry 7-inch rims that accept 215/60 VR15 radial-ply tires. These enhance both cornering and drive traction at the rear of the car. To make room for these wider tires, the rear fenders are more deeply flared.

As an option, the 911SC may be equipped with forged light alloy wheels designed to carry the 16-inch, ultra-low profile radial tires originally introduced on the Turbo Carrera. These tires set new standards for high-speed endurance, lateral control, swift, sure braking, and roll-off and water drainage.

Specifications, options, and standard equipment subject to change without notice.

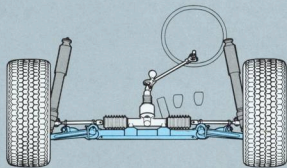

Front suspension

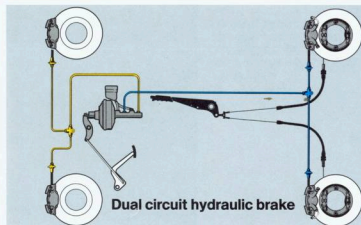

Dual circuit hydraulic brake

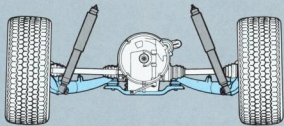

Rear suspension

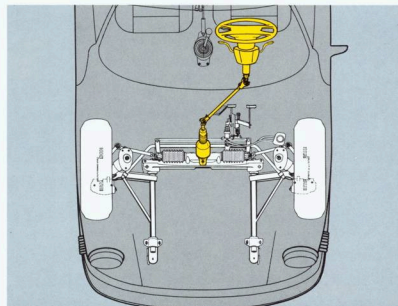

Front axle with steering assembly

Porsche 911SC: Quality Before Quantity.

All Porsches are manufactured in relatively small numbers. As a result, Porsche drivers do not see themselves coming and going at every stoplight. And there are significant differences in the way Porsches are assembled compared with the great mass of volume production cars.

Functions that take seconds at other auto plants are measured in minutes at the Porsche plant. Each worker, instead of performing two or three operations, is responsible for a significant "piece of his Porsche." The result is a justifiable pride in the product, and an identity with a heritage built up over a period of 30 years. This workmanship and involvement has earned the Porsche a worldwide reputation as a top quality product of German precision.

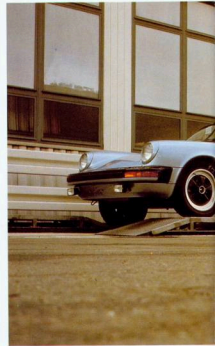
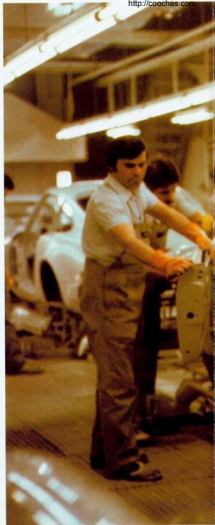



Beginning with the material-receiving division, and on through to the final quality control and inspection, each Porsche detail is subjected to a host of visual inspections, and functional and test-stand controls.

For example, prior to its installation in the car, each 911SC engine is subjected to a one-hour test stand run. It must demonstrate conformance to all values—power output, fuel consumption, exhaust gas emission, tightness, and noise—with zero deficiencies permitted and with tolerances maintained within an extremely narrow range.



By virtue of these stringent measures, Porsche owners are relieved of the necessity for strict adherence to running-in instructions. All that is required during the break-in period is avoidance of excessive and prolonged stress during the first 500-1000 kilometers.

In fact, every new 911SC has already been "driven" 20-30 km before reaching its new owner. Each new 911SC is subjected to an adjustment run of approximately 10 minutes on the dynamometer. Some are also taken on a road test. A total of 180 different check points are monitored by the critical eye, trained ear, and sensitive hands of an experienced test driver.

The result of these painstaking and expensive controls are sports cars exhibiting a level of manufacturing perfection not often found in today's market.

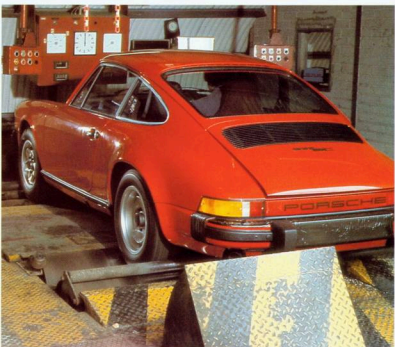
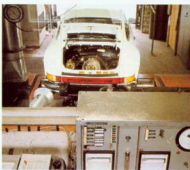



Porsche Proving Grounds Weissach, Cradle of Progress.

Covering some 450,000 square meters, the Porsche Research and Development Center in Weissach is even larger than the original production plant in Zuffenhausen.

While this ratio may seem paradoxical at first glance, it is fully understandable when one considers just how much thinking, innovation, programmed safety, automotive engineering, and racing experience is invested in every new Porsche. Seen in this light, the vastness and complexity of the Porsche "think tank" in Weissach becomes comprehensible.

Here, all Porsche ideas are processed within a constellation in which innovation and creativity are highly valued. Concepts take shape, beginning first as tentative ideas on the drawing board, then progressing through many stages.

Before Porsche engineers incorporate performance related ideas on a production car, it will have proven itself time and again on many factory team race or rallye cars built, tested, and tuned at Weissach.

Even more impressive than the race tracks, skid pad, and cross-country test tracks at Weissach are the computer-controlled testing and measuring facilities, developed in large measure by Porsche. It is these that make Weissach more efficient than most research centers with many times the area and personnel of Weissach. In fact, Porsche uses only half the available capacity for its own purposes. The other half is occupied with research studies and development work for government agencies, institutes, accessory and tire manufacturers, and even for participants in its racing competitions.

In the final analysis, it is the Porsche owner who profits from the problem-solving always underway at Weissach. Because in the end, all of the know-how and technology developed at this facility is incorporated in Porsche sports cars.

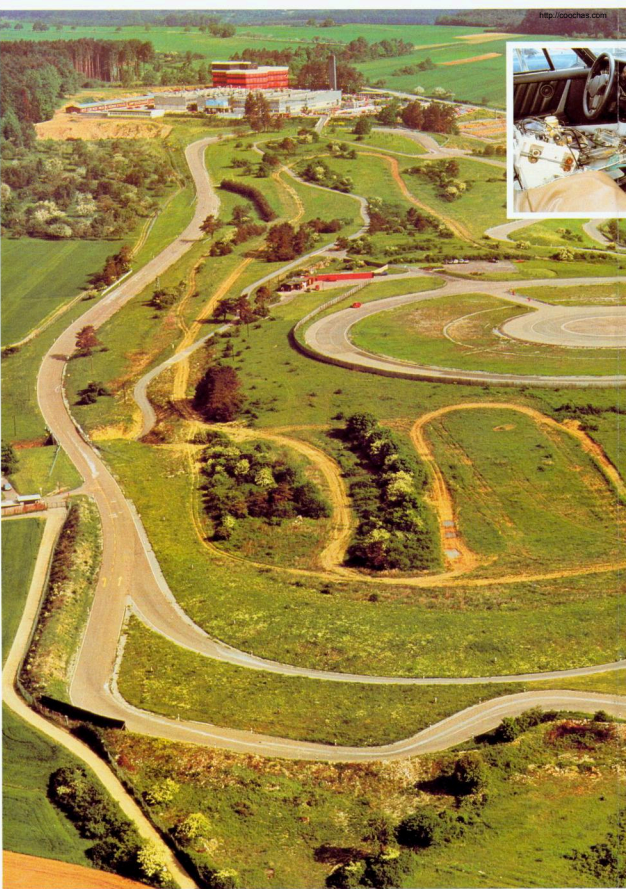



Porsche 911SC: Armed Against the Elements:

Every Porsche since the very beginning has used an advanced construction principle borrowed from aircraft design. The body and frame are an integral or monocoque structure in which the platform frame and steel body are welded into a rugged, rigid whole.

This, in part, accounts for the solid strength of the 911SC body and its stubborn resistance to developing squeaks and rattles over a very long lifetime. To match this strength, Porsche has taken extraordinary steps to help block corrosion that often mars and weakens ordinary steel auto bodies.

The entire bodywork sheetmetal of the 911SC has gone through a hot-dip galvanizing process on both sides to form a protective shield against corrosion. Galvanizing is costly and requires special methods for welding parts treated in this manner. If they use it at all, most auto makers apply it to only a few parts. In the interest of longer body life, Porsche makes the 911SC's body of material that has been treated by the Thyssen process. This permits Porsche to offer a seven-year limited warranty covering rust perforation of the body platform and all supporting body elements. (Ask your dealer for a copy of this warranty.)

Even this, however, is not in itself enough. Parts are also dipped in an electrically-charged bath of primer paint. And a thick layer of Polymer undercoating is baked on.

Similar "over engineering" of mechanical components of the 911SC results in minimal service requirements over the life of the car. For example, after the first 1000-mile servicing, major servicing and oil changes are required only every 15,000 miles (see Owner's Manual for details).

This distinguishes Porsches from many other sports cars. It makes a Porsche an ideal choice for tough, everyday use in any climate, and in any sort of traffic condition.

Specifications, options, and standard equipment subject to change without notice.



In harsh northern climates, for example, the heated outside mirror of the 911SC will be particularly appreciated.

Heating elements within the mirror assembly prevent it from becoming ice-covered or fogged-up. And the unit is electrically adjustable as well. Similar heating elements are also found in the rear windows of the 911SC Coupé and Targa.

For clear visibility in anything from a drizzle to a downpour, the front windshield wipers have three speeds plus an intermittent setting. Also, an optional headlamp washer system provides full lighting when it is needed most, in bad weather and on dirty roads.



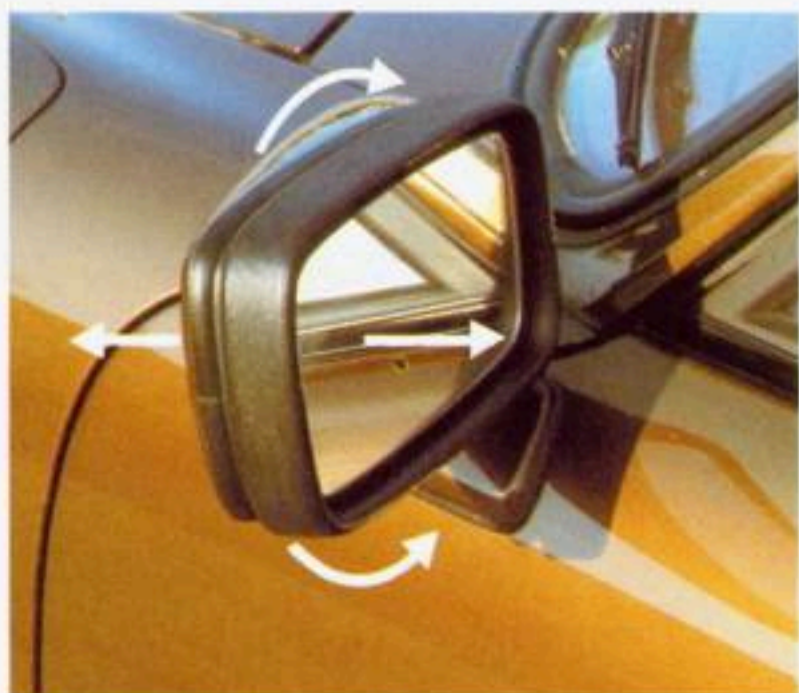
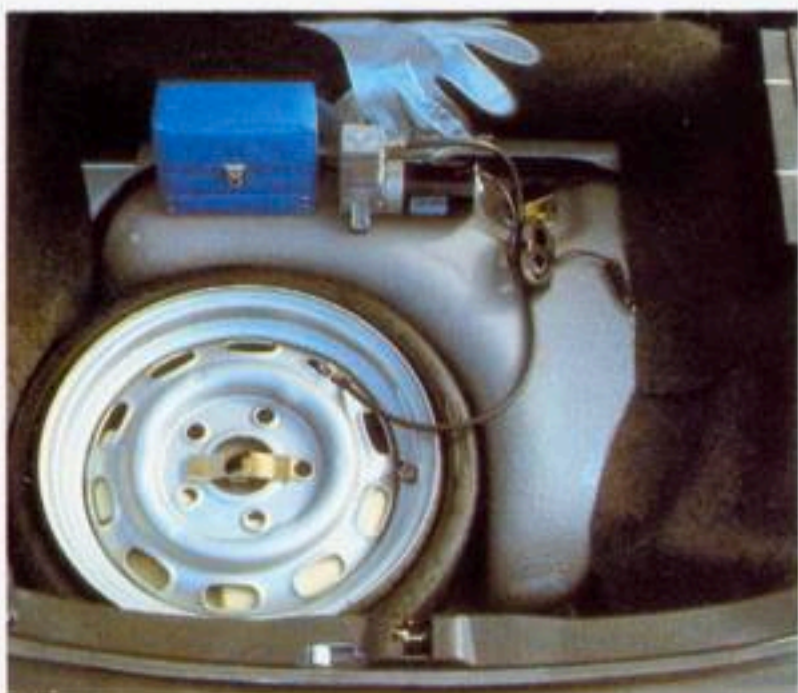

Porsche 911SC: Where Driving is Still Fun.

Driving a conventional automobile has never been pure fun, and perhaps is even less so today. In fact, the only true adventure left may be finding a parking space.

Driving a thoroughbred sports car can provide unalloyed pleasure, even with today's congested roads and numerous restrictions and regulations. Not because one can drive faster behind the wheel of a Porsche, but simply because one drives it more consciously. With greater concentration. And with an almost forgotten enthusiasm for its near perfect performance, responsiveness, and incomparable charm.

Porsche 911SC. One of the few places where driving is still fun.

Any catalog attempting to describe a product as dynamic as Porsche 911SC must, by definition, be two-dimensional. Even with the finest pictures and words, the information must remain incomplete, lacking as it does the dimension of motion.

Only by driving the 911SC can one discover the true appeal of a Porsche. Only then does one feel and experience it as a special enjoyment. As a truly living adventure. Only then does one sense its power, its acceleration, its sovereign perfection. Porsche 911SC captivates its driver as it flattens mountains, shortens passing maneuvers, shrinks distances, and makes driving time pass quickly and enjoyably. Behind the wheel of a Porsche, driving pleasure is always at hand, whether cruising down the avenue or breezing down a country lane in an open Targa.











Porsche 911SC: The Complete Sports Car.

Standard appointments geared to Porsche's highest level of luxury:

- 3.0 liter six-cylinder air cooled engine
- CIS fuel injection
- 172 Horsepower SAE net
- Oil cooler, front
- Five-speed fully synchronized transmission
- Four-wheel independent torsion-bar suspension with stabilizer bars, front and rear
- Welded unitized body
- Four-wheel vented disc brakes, power assisted
- Light alloy wheels
- Remote-controlled outside rear-view mirror with electric defroster
- Halogen headlamps
- Radial ply tires
- Rack and pinion steering
- Transistorized breakerless ignition
- Inertia-reel seat belts, front, and lap belts, rear
- Reclining bucket seats
- Leather-covered steering wheel
- Transistorized tachometer
- Trip mileage odometer
- Quartz clock
- Electric rear window defogger, two-stage
- Tinted glass all around
- Deep cut pile carpeting
- Electric windshield wiper with intermittent wipe cycle
- Air Conditioning

Porsche 911SC Options: Customizing Your Porsche the Porsche Way.

A wide range of options is available to help you personalize your 911SC. Some of your choices have already been mentioned, such as that between the Coupé and the Targa. Yet another is the Porsche



palette of body and interior trim colors. Or the special low-profile tires.

Here are more options to enhance your driving comfort:

- Digital cassette radio with clock, manual antenna, and speakers in doors
- Leather sport seats
- Electric sliding sunroof (Coupé only)
- Power windows
- Forged alloy wheels
- Black headliner—Coupé only
- Headlamp washers
- Fog lights, white
- Limited slip differential
- Automatic temperature control
- Automatic speed control
- Power antenna
- Front and rear spoiler
- Sport shock absorbers
- Luggage rack

Ask your Porsche salesperson for complete details on these options.

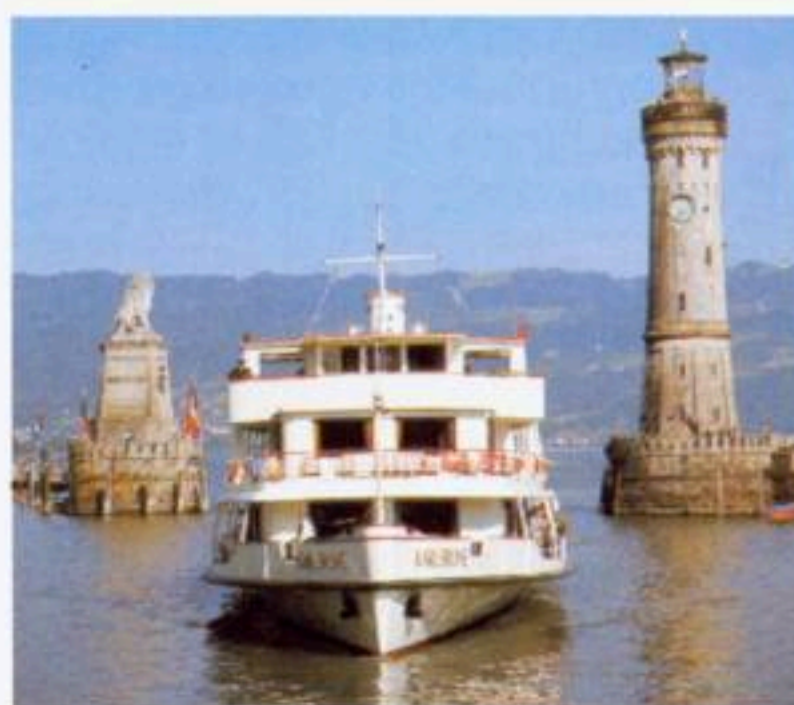

Volkswagen of America, Inc. believed the specifications in this brochure to be true at the time of printing. However, specifications, standard equipment and options are subject to change without notice, some of the vehicles and equipment shown or mentioned in this catalog may not be available in some areas.

PORSCHE

911 SC

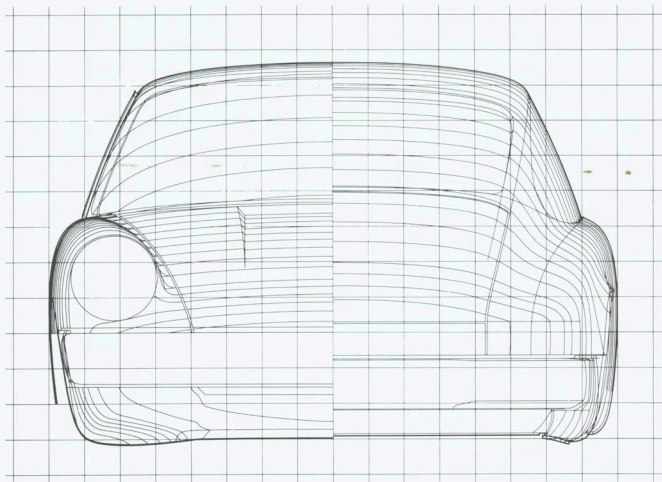

Technical Data
1981

911 SC

Chassis, Suspension	Self-supporting body shell, independent front suspension with wishbones and shock absorber struts
Front springs	Torsion bars
Rear suspension	Independent, semi-trailing arms
Rear springs	1 transverse torsion bar per wheel
Shock absorbers	Front and rear hydraulic double-acting shock absorbers
Stabilizers	Front and rear, 20/18 mm
Power-assisted brakes	With ventilated discs on all 4 wheels
Rims	6 J x 15 – front; 7 J x 15 – rear pressure-cast light alloy
Tires	185/70 VR 15 – front 215/60 VR 15 – rear
Steering	Rack and pinion
Capacities	
Engine oil	13.7 U.S. qts. (1.3 liters)
Gear box and final drive	3.2 U.S. qts. (3 liters)
Fuel tank	21.1 U.S. gal. (80 liters)
Windshield washer reservoir	2.2 U.S. gal. (8.5 liters)
Dimensions	
Wheelbase	89.5 in. (2272 mm)
Track, front	53.9 in. (1369 mm)
Track, rear	54.3 in. (1379 mm)
Length	168.9 in. (4291 mm)
Width	65.0 in. (1652 mm)
Height (unladen)	51.6 in. (1320 mm)
Ground clearance (laden)	4.7 in. (120 mm)
Turning circle diameter (curb to curb)	34.0 ft. (10.4 m)
Weights	
Unladen weight (DIN standard incl. fuel)	2756 lbs. (1250 kg)
Permissible gross weight	3417 lbs. (1550 kg)
Performance	
Top speed	139 mph (225 km/h)
Acceleration 0–60 mph	6.9 seconds

Specifications, standard equipment and options subject to change without notice.

1981 **911 SC****Engine**

Number of cylinders	6
Bore	3.74 in. (95 mm)
Stroke	2.77 in. (70.4 mm)
Displacement, effective	183.0 cu. in. (2994 cc)
Compression ratio	9.3:1
Engine output SAE net	172 hp (128 kW)
At engine speed RPM	5500
Max. torque – SAE net	175 ft. lbs. (237 Nm)
At engine speed RPM	4200
Fuel octane requirement	Lead-free only

Engine Design

Layout	Air-cooled, four-cycle, horizontally opposed
Crankcase	Light alloy
Cylinders (individual)	Light alloy
Valve position in cylinder head	1 inlet, 1 exhaust; inverted V-pattern
Valve operation	Single overhead camshaft for each cylinder bank
Camshaft drive	By double chain
Crankshaft	Forged steel, 8 main bearings
Lubrication	Dry sump with separate oil tank, thermostatically controlled oil cooling, full flow oil filter
Fuel supply	Electric fuel pump
Mixture supply	Continuous Injection System

Electrical System

Battery voltage V	12
Battery rating (Amp/h)	66
Generator	980 W alternator
Ignition	Breakerless capacitive discharge system

Transmission

Clutch, mechanically assisted	Single dry plate
Manual gear box	Porsche Synchromesh
Number of speeds	5 forward, 1 reverse
Final drive	Spiral bevel, pinion and differential
Rear axle half shafts	Double constant velocity joints
Shift lever location	Floor-mounted shift control
Final drive ratio	31/8 \approx 3.875 : 1

PORSCHE

© 1980 Porsche + Audi Division
Volkswagen of America, Inc.
W 73-711-6031
Printed in W. Germany

