

Leading-Edge Motorsport Technology Since 1990

Racecar engineering™

May 2011 • Vol21 No5 • www.racecar-engineering.com • UK £5.50 • US \$12.50

IT'S A BRAVE NEW WORLD

Charting the big changes coming for IndyCar in 2012

FORMULA 1 STOPPING POWER

The latest developments in cutting-edge brake technology

WORLD RALLY CHAMPIONSHIP

Why the new cars are setting the stages alight

HOW TO WIN THE INDY 500

Top engineer reveals strategy secrets for The Great Race



McLaren moves into NASCAR

Top name helps Sprint Cup switch to fuel injection



Introducing the open source racecar

A groundbreaking approach to design and development



The 1972 Parnelli VPJ1 Indy Car

Radical looks that flattered to deceive



Xtraordinary Fluid Delivery

Made in U.S.A. For Over 20 Years

High-quality American-made aluminum fittings from domestic alloys are what we do!

Do you know where your hose ends and adapters are really made? Beware of imported products with no country of origin markings. XRP's are made in the USA from proper aircraft-grade alloys, heat treated for strength and long durability. There is a difference!



Effective filtration. High-volume flow.
Ultra-lightweight, space-saving design.

NEW In-line Fuel Filters. Includes O-rings for alcohol or gasoline use.



10, 20 and 40 Micron elements are available.
-4 through -10 AN sizes.

THREE BODY STYLES AVAILABLE TO ADAPT TO A WIDE RANGE OF RACING APPLICATIONS



Threaded Body/AN ends



Clamshell Body/AN ends



Clamshell Body/Clamshell ends

METRIC ADAPTERS & HOSE ENDS



NEW Metric Thread to AN Adapters in sizes from 10mm to 30mm and -4 to -20 AN Flare. Hose ends with Metric DIN standard convex ball radius seats and Metric swivel nuts.

REDUCERS, EXPANDERS & TUBE ADAPTERS



NEW Reducers and expanders are designed for use with either our stainless steel braided CPE hose, XR-31 hose or our ultra-lightweight HS-79 hose. Tube adapters allow hardline to be fitted to AN adapters and hose ends.



XRP®

THE XTREME IN RACECAR PLUMBING

Go to www.xrp.com for catalog downloads & new products or contact us for our new 92-page color catalog available soon.

UNITED STATES XRP, Inc. sales@xrp.com tel 562 861 4765 fax 562 861 5503
EUROPE James Lister & Sons motorsport@lister.co.uk tel 44 (0) 121 525 5800 fax 44 (0) 121 553 5951



With the 2011 edition of the Indianapolis 500 marking the centenary of this famous event, it seems appropriate that this month's *Racecar Engineering* takes an in-depth look at the considerations that go into developing a winning strategy for the modern day version of 'The Great Race'. To do this, we asked Andy Brown, until recently senior engineer at Target Chip Ganassi Racing, to explain how teams prepare for this unique event. It makes for fascinating reading.

Interestingly, that first Indianapolis 500-Mile Race of 1911 - or the International 500-Mile Sweepstakes Race, as it was called - turned out to be something of a controversial affair. Held at the Indianapolis Motor Speedway on Tuesday, May 30, the event attracted widespread interest from racing teams and manufacturers on both sides of the Atlantic, with the distance of 500 miles being chosen so fans could arrive and return home in daylight. It also boasted a previously unheard of purse of \$25,000, with a further \$15,000 on offer in contingency prizes.

The history books record that local man, Ray Harroun, who came out of retirement to compete in the race, driving a Marmon-Nordyke 'Wasp' for Indiana businessman, Howard Marmon, was the winner. During the course of the race, however, there were problems with the timing wire of the Warner Harograph, a key component of the Speedway's timing and scoring system at the time, likely errors and omissions by the judges as the result of a multi-car pile-up and, setting the precedent for what was to become something of a motor racing 'tradition', the filing of a number of protests.

The morning after the race, with the third set of results having been posted, Harroun was confirmed as the winner, with Californian, Ralph Mulford, in a Lozier, second, and David Bruce-Brown's Fiat rounding out the top three. Harroun returned to retirement after the event, never to compete again, but having assured himself a place in motor racing history.

EDITOR

Graham Jones

For more technical news and content go to www.racecar-engineering.com



12 COVER STORY
Top engineer on how to develop a winning strategy for the Indianapolis 500

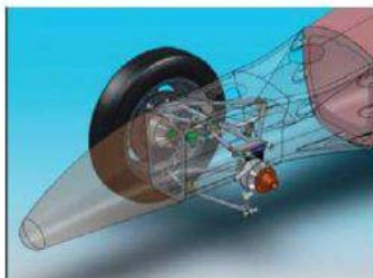

48 OPEN ALL HOURS
Open source could be the answer to keeping motorsport relevant



69 ON THE BRAKES
In the first part of an in-depth series, we focus on calipers and cooling

The International Journal of Motorsport Technology
Racecar
engineering™

NEWS

- 4** F1 for a racing rhinoplasty? New Le Mans Prototypes, Firestone tyres, new products
- 10** The Hispania Dallara is the subject of technical update this month

RACE PEOPLE

- 93** **People** who has gone where recently and what they've gone there to do
- 98** **Late Apex** Why motor racing should not be manipulated with rain, levers or banana skins

ENGINEERING SOLUTIONS

- 12** **Oval racing strategy** Andy Brown reveals his secret box of pit lane tricks
- 32** **Indycar 2012** The latest on the changes that will affect the future of IndyCar
- 53** **NASCAR Injection** Inside the new Sprint Cup ECU from McLaren Electronic systems
- 62** **Ford Fiesta** M-Sport's 2011 spec World Rally Car revealed in the first of a WRC two-part
- 69** **F1 brake technology** AP Racing explains what it takes to stop a grand prix car.

FIRST PRINCIPLES

- 21** **Aerobytes** Front wing endplate developments on the DJ Firestorm
- 25** **Consultant** Mark Ortiz on the subtleties of anti-roll bars and load transfer
- 29** **Databytes** Cosworth urges you to use more advanced mathematics

DESIGN AND INNOVATION

- 41** **Parnelli VPJ1** we take a look back at a time when Indycar meant innovation
- 48** **Crowd sourcing** Ben Bowlby explains why open source design could be the future
- 59** **Project Lightning** PTC unveils Creo, its vision for the next 20 years of 3D modelling

INDUSTRY

- 82** **Industry news** University courses under threat and Chris Aylett on motorsport to cars
- 88** **Technical Forum** Optical lift and how a curved surface is affected by the streamlines of passing energy

Subscribe to *Racecar Engineering* - find the best offers online
www.racecar-engineering.com

FORMULA 1

Formula 1 for a nose job?

FIA Institute looks to solve problem of launch accidents

The FIA is looking into changing the design of the noses on Formula 1 cars as it investigates ways of preventing accidents such as Mark Webber's horrific aerial crash at last year's European Grand Prix.

Webber's crash was caused when his Red Bull rode up the rear tyres of the slower Lotus of Heikki Kovalainen and was launched into a series of somersaults. Now the FIA Institute's technical adviser, Andy Mellor, has gone on record to say that it's looking at ways to solve the problems of cars launching after nose to wheel collisions.

'The key aspect is the nose height of the car behind, as this will determine whether or not launch occurs,' said Mellor in the FIA's new IQ Magazine, adding that it's not just a matter of banning high noses, as low nose designs will often mean a nose will 'submarine' under a rear wheel rather than lift up in a collision.

'Another influential factor is velocity and the resulting fore-aft acceleration and vertical acceleration,' Mellor said. 'Nose-to-wheel science is solved. There are very definite parameters by which these contacts do not cause a launch. The knowledge certainly exists, so it just needs to be eradicated.'

It's thought unlikely that the FIA will ban high noses completely, but rather there will be a redesign of the front wings, which will help to keep a car's nose down after a collision with a car in front.

Meanwhile, some F1 drivers, world champion Sebastian Vettel among them, have said that they believed that the new movable rear wing - a device to aid overtaking on specific parts of the circuit during the race - could cause problems during practice sessions and qualifying, when its use is not limited. It is thought that the new device could lead to cars

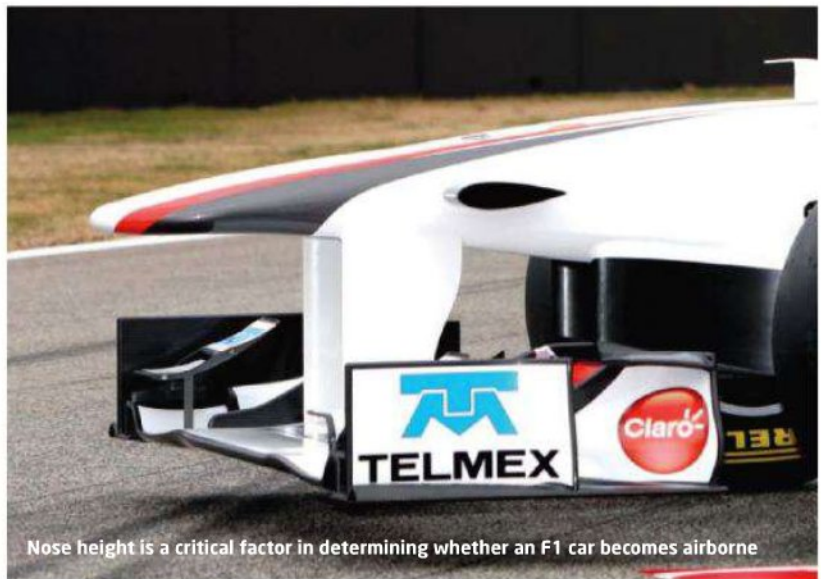

Nose height is a critical factor in determining whether an F1 car becomes airborne

becoming unstable in high speed corners, if the device is used in them.

Veteran racer Rubens Barrichello has also expressed concerns that drivers might become distracted as they try to use both the movable wing and KERS - making its return for 2011 - during a flying lap.

In other F1 news, the sport's ringmaster, Bernie Ecclestone, has told the Australian Associated

Press that he does not believe environmentally friendly engines - such as the four cylinder units coming in 2013 - will be good for the sport. 'I'm anti, anti, anti, anti, moving into this small turbo four formula,' he said. 'We don't need it, and if it's so important it's the sort of thing that should be in saloon car racing.'

The F1 boss also admitted he was in

disagreement with FIA president Jean Todt over the issue: 'He's not a promoter and he's not selling Formula 1. To be honest, Jean and I are a little bit at loggerheads over this engine. I don't see the reason for it.'

Ecclestone added: 'We had the KERS system and this was supposed to solve the problem that Formula 1 is not green and now we've got something else.'

SEEN: MCLAREN MP4-12C GT3



The all-new McLaren MP4-12C GT racer has started its test programme, rolling out for a shakedown at MIRA. The car, which has been developed by McLaren in conjunction with GT team CRS Racing, is based on the McLaren carbon MonoCell chassis, while race spec composite body panels and a fixed rear wing have been added. The same 3.8-litre twin turbo V8 as in the production car is used, tuned to race specification, and a bespoke paddle-shift system operating an all-new Ricardo-designed gearbox is fitted. A new aerodynamics package has been developed by McLaren Racing, incorporating a new front splitter, door blade, rear wing, diffuser and louvers in the front fenders. Because of GT regs, the 12C GT3 does not feature the road-going 12C's ProActive Chassis Control System, which negates the requirement for an anti-roll bar. Instead, the 12C GT3 uses a configuration comprising race-specific roll bars and dampers.

ENDURANCE

LMP1 petrol challengers hit the track

The two petrol fuelled racecars most likely to take the fight to diesel dominators Audi and Peugeot for top honours at Le Mans this year have been out on track for the first time, with the Aston Martin AMR-One making its testing debut and the HPD ARX-01e impressing at Sebring.

Aston Martin's new AMR-One LMP1 hit the track at Prodrive's Warwick test facility and then at Snetterton in March, and now faces a heavy test programme until its race debut at Paul Ricard in April.

The AMR-One is open-topped and powered by a 2.0-litre turbocharged straight six Aston Martin Racing-built engine, a surprise to many who expected it to pack a normally aspirated 3.2 V6. George Howard-Chappell, AMR team principal, said: 'We have chosen to run with a six cylinder turbocharged engine because we believe this offers the best potential within the petrol engine regulations. With the ACO's commitment to effectively balance the performance of petrol and diesel Le Mans entrants, our hopes are high that we'll see the closest racing yet in the premier LMP1 category.'

AMR has chosen the



Aston Martin Racing has gone with an open-top design and turbocharged straight-six power for its AMR-One LMP1 contender

open-top approach, as opposed to the coupe, because of its practicalities, it says, but is still confident of the car's radical aerodynamic package, which was developed using CFD and not in a wind tunnel.

Meanwhile, HPD's LMP1 ARX-01e made an impressive debut at the recent Sebring 12-hour event, where it raced to a fine second place after very little testing. The car is an updated version of the LMP2-spec racer HPD used to take last year's ALMS title, but features new suspension and aerodynamics developed by Wirth Research plus the requisite power hike to move up

into the top class. The V8 is now fed through a larger air restrictor, allowing the engine to develop greater power.

Steve Eriksen, HPD vice president, said: 'The way the rules have gone this year, it seemed like a natural fit to take the engine that has been so successful in the LMP2 class and use the basis of that for the LMP1 class ... With the change in restrictor size and wheel/tyre package available, we believed we could have a pretty competitive package, especially considering the ACO's desire to better balance the performance of the diesel and petrol powered cars.'

BRIEFLY...BRIEFLY

NEW TEAM FOR BMW

BMW has chosen a brand new outfit as one of the three works teams for its DTM comeback next year. Reinhold Motorsport has been set up purely with the intention of running the Munich marque's cars in Europe's premier tin top championship, and the squad includes experienced staff from GTs, WRC, F1 and DTM, says its founder, Stefan Reinhold. The other BMW teams are marque stalwarts Schnitzer and RBM.

SPEED BOOST

The SPEED EuroSeries for CNC prototypes has been awarded FIA official series status. EuroSeries will run at Le Mans Series races this year and at one stand-alone event at Donington in June, bolstering its claim to be a viable LMS feeder formula. SPEED struggled for entries when run as a UK championship last year, but now it's expecting grids of at least 30 cars with chassis from Ligier, Norma, Juno, Wolf and WFR to the fore. Meanwhile, British Sports 2000 constructor Loaded Gunn Racing is also looking at fielding an evolution of its Gunn TS11 in SPEED.

ROUND AND BLACK AND...

New F1 tyre supplier Pirelli has revealed the colour codings it will use so that spectators and TV viewers will be able to distinguish between the six different types of tyre to be used throughout the 2011 season. The colours will be carried on the 'Pirelli' and 'PZero' logos on the tyre walls. Tyre/colour combinations are: wet (orange), intermediate (light blue), supersoft (red), soft (yellow), medium (white) and hard (silver).

FORMULA 1

HRT leaves it late

For the second year running, Spanish F1 outfit HRT was forced to start its season with no testing after its new car was prevented from running at the final pre-season test, at the Barcelona circuit.

The HRT F111 was unveiled just the day before the last day of the test, when it was due to run, but it was then discovered its dampers were held up in customs. Just like last year, then,

the car's first run will have been at the opening grand prix of the new season.

HRT's F111 is said to be a completely new car with absolutely no parts carried over from last year's Dallara-built machine. Colin Kolles, team principal at HRT, said shortly before the launch: 'The F111 is being made by Hispania Racing with several groups of engineers ... There are approximately 40

designers finalising the first spec, under the leadership of Geoff Willis as technical director and Paul White as chief designer.'

Perhaps the most interesting feature of the new car is its gearbox, hydraulics and rear suspension package, all of which is a direct carry-over from last year's Williams.

Aerodynamic touches include a unique nose treatment, with the outer edges blending into the camera mounts, and a three-element front wing with



relatively simple endplates.

Meanwhile, the sidepods feature a forward undercut and gentle bumps atop, showing how the radiators have been squeezed into the tighter space.

Performance Starts Here...

Supertech Performance



High Performance
Engine Valves, Pistons and Components



INDYCAR

Last gasp Firestone deal for IndyCar

IndyCar has agreed a deal to keep long-time tyre supplier Firestone in the championship after a concerted effort by the teams helped to change the tyre giant's mind about quitting the USA's top single seater series.

Firestone, which is Bridgestone's American tyre operation, had announced that it was to end its latest spell in top line US single seaters, which dates back to 1996, after initial talks with IndyCar came to nothing, largely because Firestone was asking for a far higher price for its rubber if it was to continue beyond the 2011 season.

However, the team bosses have now agreed to pay Firestone double last year's rate and the tyre company has signed a new three year deal, giving the championship much needed stability on the tyre front as it goes into its new formula next year.



After some hard bargaining, Firestone will now remain as IndyCar's official tyre supplier

IndyCar CEO Randy Bernard said: 'We had reached the deadline where both organisations had to make a decision regarding the future to prepare our individual operations for the long term. This is one of those decisions that it is

imperative that you have the team owners 100 per cent behind you. We called a meeting to walk the team owners through the process and to hear their input. As a result, I'm happy to say we walk as one with Firestone.

'We feel that this

new supply agreement will benefit everyone. It provides a proven safe and reliable Firestone product for the transition to the all-new cars for 2012. We have to thank everyone at Firestone for working with us to help ensure the best for the long-term growth of our sport.'

Dennis Reinbold, co-owner of IndyCar team

Dreyer and Reinbold, said: 'IndyCar called a meeting to inform the team owners of Firestone's departure. When we learned of this, we encouraged IndyCar to check with Firestone to see if there might be any chance to continue. We feel that it is important to maintain continuity with their excellent tyres as we transition to the new car for 2012.'

Reinbold added: 'The team owners are collectively very relieved that Firestone had an open mind and that they were able to reach this agreement with IndyCar. Firestone Racing tyres are not only important from a safety and reliability standpoint, but they contribute greatly to the wheel-to-wheel competition for which our sport is famous.'

The Firestone brand has been associated with Indy-style racing since 1911, when its tyres were on the winning Marmon Wasp in the inaugural Indianapolis 500.

WRC

Volkswagen set to enter World Rally Championships

As Racecar went to press German motor giant Volkswagen was thought to be close to rubber stamping its entry into the 2012 World Rally Championship.

The long-rumoured arrival of VW in the WRC is a massive fillip for the championship, already boosted by the arrival of Mini and the success of the new WRC formula. Up until this year, the WRC had been the preserve of just two manufacturers, Citroen and Ford.

VW is thought to be planning a well-funded assault on the championship, with some WRC insiders suggesting a budget as big as £80m a year.

The company would not be drawn on details of its assault, but it's believed that despite recent speculation that its Scirocco would provide the base car,

the Wolfsburg concern will now build its WRC challenger around its Polo model.

Francois-Xavier Demaison has been entrusted with the design of the car - he has previous experience with Subaru, Peugeot and Citroen - while former WRC champion, Carlos Sainz, is expected to take on an advisory role in the team.

Meanwhile, VW has put paid to rumours that it's to be involved in NASCAR, Ulrich Hackenberg, VW head of technical development, saying: 'Nothing for us. There is certainly the one or the other person out there in the world who would wish for that, but we don't have that on the programme.'

He added: 'I should know what I am talking about, since it would come out of my budget.'

▶ WATCH THIS

Go to www.racecar-engineering.com to discover the secrets of Laurel Hill and how Ben Bowlby has reinvented the wind tunnel.



The one in the middle wins races



DS1.11® & DS2.11®

SILOXANE TECHNOLOGY

BRAKE PADS



FEDERAL MOGUL

The best brands in the business

Relative Performance Characteristics of Ferodo Racing Range Under Heavy-Duty Conditions

	Pad Life	Disk Life	Average mu	Fade	Pedal Travel	Release
DS 2500	Good	Good	Good	Good	Good	Good
DS 3000	Good	Good	Good	Good	Good	Good
DS 3000+03	Good	Good	Good	Good	Good	Good
DS 3000E	Excellent	Good	Good	Good	Good	Good
FER 4003	Good	Good	Good	Good	Good	Good
DS 1.11	Excellent	Good	Good	Good	Good	Good
DS 2.11	Excellent	Good	Good	Good	Good	Good

Excellent
Good
Moderate

www.federal-mogul.com/ferodoracing

Race Proven

- DS1.11 - suffix "W"
- A1GP
- FIA FT
- Touring Cars
- Formula Cars
- Group N
- Stock Cars
- DS2.11 - suffix "X"
- WRC
- Rally Group N
- Touring Cars



Circuit Supplies (UK) Ltd

Unit 8, Eden Court, Eden Way

Leighton Buzzard, Beds LU7 4FY

Tel: 01525 385 888 Fax: 01525 385 898

info@circuitsupplies.com www.circuitsupplies.com

WORKSHOP

WELDWIDE GAS ANALYSER

Welding equipment supplier, Weldwide Solutions Limited, has released two new models of weld gas analysers that will both accurately and reliably measure the oxygen content in purge environments. The idea is to provide optimum conditions for stainless welding, which is especially important in high-stress applications. Furthermore, the gas analysers will immediately indicate whether unwanted oxygen penetration occurs during welding, and therefore eliminate weld oxidation and costly repairs, and considerably improve weld quality.

The Ar-Gone WGA is already a well-known model in the industry and provides accurate measurements down to 0.01 per cent oxygen, together with ease of handling and long-lasting performance. The Argo-Naught WGA is a new design that gives precise measurements down to 0.1 per cent oxygen and combines exceptional stability,



easy, push-in sensor change and an air and watertight casing for ease of use and longevity.

For more information see www.weldwidesolutions.com

HARDWARE

WELDON SPORTSMAN PUMP

US-based fuel pump producer, Weldon Racing Pumps, has announced a new and innovative fuel pump with an integral bypassing regulator. Called the Sportsman, it is light weight (4.1lb) and supports race engines producing over 1200bhp. Rated as continuous duty and with a convenient, hand-adjustable knurled knob on the bypassing regulator (no adjusting tools required), the pump features multiple mounting provisions on its base and is therefore easily

interchangeable with most similarly rated fuel pumps. **For more information see www.WeldonRacing.com**



DRIVETRAIN

LUNATI CAMSHAFTS

US Camshaft manufacturer, Lunati, has announced a new series of asymmetrical camshafts, the TL2 and TR2 series, designed for use in small and big block Chevrolet racing engines. Both series of camshafts are designed using the latest technology and feature increased lobe lift. Depending on valvetrain weight,

the manufacturer claims the new camshafts can provide stability up to 8,800rpm.

The two new profiles have been specifically developed for short track Modified, Dirt Late Model, Sprint Car and drag racing applications.

For more information visit www.lunatipower.com

SENSORS

GILL LMS OIL SENSOR

UK sensor specialist, Gill Sensors, has designed a bespoke catch tank oil level sensor for use in the 2011 Le Mans Series. Specified as a compulsory monitoring device in the 2011 series regulations, the sensor is designed to be installed in the top surface of the oil catch tank on every race car in the series, providing a continuous analogue output relative to the level of oil within the tank. The sensor has been introduced by the ACO with the aim of preventing the over-filling of oil tanks, which can lead to oil spillage and unsafe racing conditions.

For more information see www.gillsensors.co.uk

MANUFACTURING

JET EDGE WATER JET CUTTER

New from water jet specialist, Jet Edge, the Jet Edge mid-rail gantry water jet cutting machine is capable of producing complex parts out of virtually any material, and features an exposed tank that easily accommodates overhead loading. It comes standard with one abrasive jet cutting head, though a second cutting head can be added to increase

productivity. Additionally, the machine is ball screw-driven for higher accuracy, while its sturdy, heavy wall, tubular steel construction eliminates vibration and increases longevity. The mid-rail gantry utilises an industrial PLC controller and can be configured so that all three axes are fully

programmable (Z optional). It also features direct-couple AC brushless digital servo motors and single or double carriages, while critical bearing components are protected with heavy metal covers with brush seals and positive air pressure.

For more information see www.jetedge.com



FORMULA 1

Hispania F111 - Cosworth

Despite announcing an all new car for 2011, the new HRT chassis is effectively a mildly developed Dallara F110 retaining many of its predecessor's major features

Hispania struggled to get its two cars ready for the Australian Grand Prix in Melbourne, with only a single installation lap completed in practice. As the 2011 nose had not passed the mandatory FIA crash test, a 2010 Dallara nose was fitted



The Hispania Racing Team (HRT) dispelled a few rumours when the F111 took to the track for the first time in free practice 2 at Albert Park. After rolling out the car at the final pre-season test in Spain, the team was unable to run the F111 due to a lack of parts - an issue that continued at Melbourne.

HRT sat out all of free practice 1 and most of free practice 2 at Formula 1's opening event of the 2011 season as chassis 1 was

built into a running car. With just four minutes of the second session remaining, driver Tonio Liuzzi took the F111 out of the pits for a single installation lap.

The Hispania F111 was rolled out towards the end of the final test at Barcelona. It is a clear evolution of last year's underdeveloped Dallara F110. Geoff Willis oversaw the work of the team's chief designer, Paul White, while the livery comes from world renowned vehicle concept designer and visionary illustrator,

As with the roll hoops, the upper portion of the sidepod is carried over from the Dallara. It houses the side impact structures

Daniel Simon.

'Starting the programme to develop the F111 has been an enormous challenge,' explains Willis. 'The group of engineers working from many separate locations had to produce the 2011

HRT chassis to meet the new regulations, package the Williams LG14 transmission, design all new rear suspension to suit, and develop a complete aero package. Given the tight time frame, I am very impressed with the result



The Hispania F111 (right) retains much of the Dallara F110 (left) in its design, with the roll hoop being identical, as well as the wing mirrors and turning vanes. One of the only updates to the F110 in 2010 involved these components, the other being a new fuel tank.



The front suspension of the F111 (above) is carried over in its entirety, and displays no changes compared with the F110 (right).

and the enormous effort everyone has put in to achieve the objective. However, we have to be realistic in our expectations of performance; this is very much a baseline car, which the team must develop in 2011.'

The Dallara roots of the car are clear to see, with the upper section of the Carbotech constructed monocoque identical to the F110, as can be seen from the roll over structure and cockpit surround.

It also appears that the upper side impact structures - mounted above the radiator ducts in the

sidepod - remain unchanged. The sidepods themselves have been revised with much smaller openings than the F110, albeit of similar shape.

The F111 and F110 roll over structures are identical, as the F111 retains the top half of the Dallara chassis. This also means the Italian manufacturer's front suspension layout is carried over.

What is new on the HRT, as mentioned, is the rear end, which employs the 2010 Williams gearbox and a new rear wing. This has led to a different rear suspension layout. The front of

the car, the nose and front impact structure have been revised and a totally new front wing installed. In Melbourne, though, the F111 was fitted with the F110 nose and front wing, as the 2011 components had not yet passed their mandatory crash tests.

Hispania was one of four new teams granted an entry to last year's World Championship, at that time, under the name Campos Meta 1. It subsequently struggled to make the first race of the 2010 season and conducted no pre-season testing - a pattern that is repeating itself this year. 

+ TECH EXTRA

www.racecar-engineering.com

More updates on the Racecar Engineering website

- Mercedes cooling problem
- Full GP technical previews
- Full GP technical reviews
- Latest comment from key team members

 **ONLINE RACE-BY-RACE FORMULA 1 TECHNICAL ANALYSIS AT**
[**www.racecar-engineering.com/formulaone**](http://www.racecar-engineering.com/formulaone)

How to win the Indy 500

In the new dawn of IndyCar, strategy is everything. An expert lets us in on some of the teams' secrets

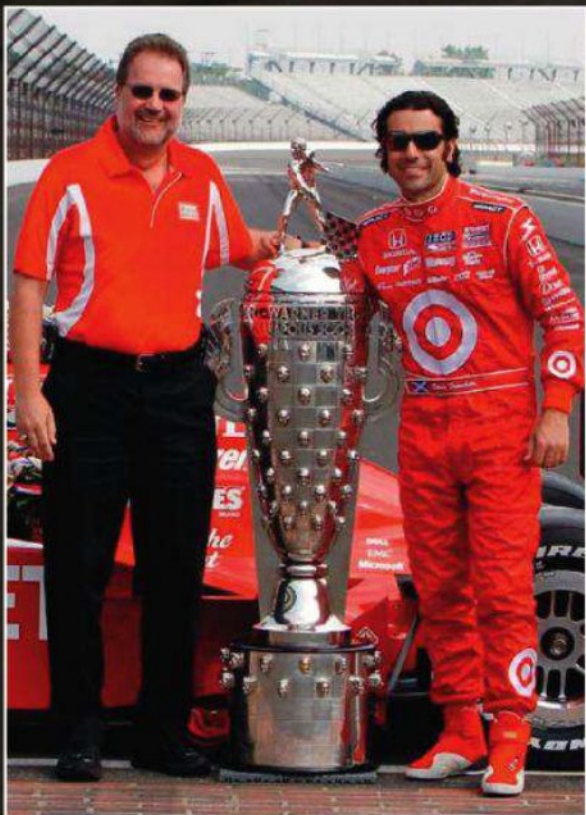

To the victor, the spoils. Andy Brown (left) and Ganassi driver, Dario Franchitti, savour the results of a winning strategy at Indy



Formula 1 race strategy is always on the lips of commentators, endless experts lining up to dissect every small decision made by the teams. But what about that other great open-wheel race, once itself part of the F1 calendar, the Indianapolis 500? On the North American ovals, because of the caution periods and the need for multiple pit stops for fuel and tyres during an event, 'strategy' has always been a significant feature.

Andy Brown has engineered the winning car at the Indy 500 more than once and has

been chief engineer at Chip Ganassi Racing, so has plenty of experience in this complex area. In this article he explains what the critical factors are in developing a winning strategy for the Indy 500.

TYRES

I've found the main strategy factor to be tyre management. In line with the worldwide trend of trying to reduce the cost of racing, the teams are now limited to 33 sets of tyres for the entire event, and 1200 engine miles (on one engine) for practice and qualifying. In my experience, though, you run out of tyres before running out

of engine miles.

The teams on a smaller budget will try and do the entire event (practice, qualifying and the race) on one engine; they are then limited to 800 practice and qualifying miles and 26 sets of tyres. If they can buy the extra sets of tyres to bring them up to 33 sets, then engine miles can become an issue.

Usually, the first decision to be made is how many sets of tyres to allocate for the race, in order to determine how many sets are available for practice and qualifying sessions. In deciding this, an educated guess needs to be made as to

how many pit stops you think you will make on race day.

Following a disastrous attempt at partial re-surfacing during the 2004/'05 off season, after the NASCAR race had chewed up the turns, the track surface was ground to eliminate the bumps and the changes in grip level due to the different patches of tarmac. This grinding process has left a series of longitudinal grooves around the entire length of the lap and, with the tyres sliding in the turns, the 'cheese grater' effect of the grooves pretty much wears out a set of tyres during a fuel stint of around 30 laps. It is therefore not unusual to see





The Indy 500 has become somewhat processional, or what Andy Brown refers to as a 'track position race'. It makes pit strategy vital

a line of chords begin to appear through the tread toward the inside shoulder of the right rear tyre by then, and so should you pit after 10 laps on a set of tyres as you are not going to have a chance to do another 30 laps on that set should another yellow not come up before you have to pit again?

Should there be *no* yellows, for a 200-lap race with 30-lap fuel stints you would need seven sets of tyres, and with the wear rate you want these to be 'sticker' tyres, not 'scuffs'. This would require six pit stops, of course, but how many extra pit stops will be required if (when) yellow flags punctuate the race?

For these reasons, I don't think it unreasonable to hold back 10 sets of stickers for the race itself. (In 2007, I was wondering if even this was going

to be enough, as by lap 100 I had already used six sets of tyres! Look at the yellow history for that event and you'll see we stopped during each one, so I was a little relieved to see the race halted short of the 200 laps because of rain).

In the Firestone era, tyre degradation has really not been a factor as the cars, if anything (and as long as set up correctly), get a little faster in terms of average lap speed as the fuel load lightens, and so this does not enter into the strategy decision-making process.

FUEL STOPS

Rule changes in this particular area have in many ways reduced the strategy options available to the teams. Two of the most influential changes have been the pit lane speed limit being

reduced to 60mph, and the reduction in fuel tank size to 22 US gallons. Prior to these factors coming into play, one rule of thumb regarding race strategy used to be that if a yellow came out, you would pit if you had used more than half a tank of fuel, otherwise you would elect to stay out. If the cars were close to a half tank being used then, if the leaders pitted, some competitors running behind them would be tempted to stay out and try and catch a later yellow as a way to get to the front and hopefully stay there. But, if the leaders chose to stay out, then those behind would possibly pit, hoping the leaders would then have to pit later under green flag racing conditions. Then - hopefully - a yellow would come out just after the early leaders had taken their green flag pit

stops and let the 'stay outers' stay at the front.

That does not happen any more as, with the pit lane speed limit currently being so slow and the rest of the field still lapping at around 220mph, you basically lose an entire lap compared with the opposition when you make a green flag pit stop. Therefore it is effectively the end of your chances if the guys you're racing against are able to make a yellow flag pit stop after you've pitted under green. And with the smaller fuel cell meaning that a 'fuel stint' is shorter than it used to be (around 30 laps at the current rate of fuel consumption), if you decide to stay out, there are relatively few laps' worth of fuel left in your car before you have to pit, so you are therefore hoping for another yellow to come out relatively quickly in



Tyre management in the Indy 500 dictates most of the strategy calls. The Speedway now has a highly abrasive surface, which is hard on race rubber

order to make your 'stay out' strategy work.

So now six or seven gallons of fuel used seems to be the cut-off point. Naturally, this has had the effect of increasing the number of pit stops you will potentially make during the race.

You may think that pitting after only this small amount of fuel has been used (less than 10 laps) you might choose not to change tyres. And indeed that would have been the case, but not now with the highly abrasive nature of the current track surface at Indy.

The result of all this is the Indy 500 has now been termed a 'track position' race by the teams, meaning you need to get to the front (the front of the pack at least) and stay there. And this begins with qualifying.

The trouble is it is not possible

to just throw everything at a good qualifying performance, as doing so means that your race car could end up being 'undriveable' on race day.

So teams will have a pre-race strategy meeting to discuss the basics, and then push out a few

It is not possible to just throw everything at a good qualifying performance

'what ifs?' and discuss possible responses to these situations. The length of a fuel stint and how many pit stops to expect will be a major topic of discussion and, as a result, methods of saving fuel will be a topic, too.

With Indy being a 'race position' event, where overtaking is difficult, one of the main

strategies employed is to hold station behind the car in front, but try and use less fuel than them, and thereby extend your fuel window by a lap or two in comparison. This should pay off when they pit earlier than you either by a) you then being

able to put the hammer down for a quick lap before your own pit stop and therefore come out in front of them after your stop, or b) if you're really lucky, they will pit under green and immediately afterwards a yellow flag comes out in time for your stop. Extending the fuel window by as much as possible is also

important then in order to give yourself the best chance of catching a yellow flag period during which to make your stop.

MIXTURE SETTINGS

Up until last year, there were different fuel mixture settings available in the cockpit and, when running in the pack, drivers would use as lean a setting as possible without losing time to the car in front. However, with Honda having the monopoly on engine supply, I guess they didn't see the point of this and the feature was removed last year. 'Full rich' and 'full lean' (the latter only to be used when running under yellow) are now the only settings provided. The drivers now have to revert to good old fashioned feathering of the throttle, preferably while also running in the tow, in order to save fuel.



Ways of saving fuel when running under yellow include simple things like switching to the full lean fuel setting as quickly as possible, using as high a gear as possible, not weaving from side to side trying to keep the tyres 'clean' and / or warm, using as constant a throttle pedal setting as possible, staying as close as possible to the car in front (even if it's the pace car), all make a difference. These all need to be stated before each race, and sometimes over the radio during the race as well.

CAUTION PERIODS

By such methods, caution periods can usefully extend a fuel stint. The ratio is generally considered three to one (ie three laps behind the pace car uses the same amount of fuel as one green flag lap) so the difference can be seen clearly. If we take the figures stated already, a stint is currently around 30 laps but, if you expect three yellow laps in a stint, you can stay out for a total of 32 laps. If you expect six yellow flag laps, a total of 34 laps will be your fuel stint.

While modern 'ship-to-shore' radio systems are on the whole very reliable, there's always the chance that a failure may occur, and when this happens it is useful for the driver to know the first lap that he can stop on and then reach the finish without running out of fuel.

Fuel consumption checks in practice will have told the team



The fuel cans (top) play a part in the race strategy, with the slower flow rate as it empties encouraging teams to short fill to maintain track position. This can also mean a quick getaway from the stop is essential. The current generation of Firestone tyres wears rapidly at Indy but the performance does not drop off

the exact length of a stint at full speed, and then a study of the probability of yellows coming out in the final phase of the race will define the 'get home' lap.

A study of the caution periods since 1997 shows the average number of yellow flags there have been in the last 30 laps as seven. So, if a green flag fuel stint is indeed 30 laps, seven yellow flags would extend this to 34 laps, so pitting on lap 166 might just get you home, especially if a yellow flag is out at that point in the race.

HISTORICAL DATA

One can also turn to other historical data to help with this decision. A study of last year's lap chart shows that most cars pitted under yellow at the end of lap 163, and the first six cars to finish the race did so without pitting again - just. And there were only four yellow laps following this round of yellow pit stops. Fortunately for those

top six, two of these yellow laps came right at the end of the race (or unfortunately, if you were Mike Conway and Ryan Hunter-Reay, see page 56).

The previous year also saw yellow flag pit stops on lap 163, but there was an extended yellow flag period (from laps 174 to 182) that year, which meant everyone could get to the finish without the dramas that we saw last year.

The drivers also have available to them on the dash a lap average mpg figure or, in some cases, a 'gallons per lap' figure. After the final pit stop, or maybe earlier if you're trying to extend the fuel stints in order to make one less pit stop overall, the driver will be told a target value that he has to match (or better) in order to complete the required number of laps.

SHORT FILLING

This is a common strategy option used to maintain track position, meaning a fuel stint that is not always the maximum length. The pit tanks at Indy are mounted quite low (for safety reasons, as this makes them less likely to be pulled over if a car departs with the hose still attached) and, as they are not pressurised, the fuel flow rate into the car is relatively slow. This means filling the car normally takes longer than changing all four tyres, especially as the level of fuel in the pit tank gets relatively low toward the end of the race. One option is to 'pull the fuel' as soon as the tyre change is complete, and hence gain places compared with those taking on a full load. This is especially effective when pitting under yellow and a whole train of cars has pitted nose to tail.

However, short filling can also be a dangerous strategy, as this now leaves you facing a shorter fuel stint than the cars around you. As we've seen before, if this causes you to have to make a green flag pit stop and the others, by virtue of staying out longer, can make a yellow flag pit stop, you may have gained a few places following the 'short fill' pit stop, but then lose out by even more at the next round of pit stops.

I've personally only ever used this technique when trying to get a lap back, especially if pitting under yellow when a lap down



Congratulations & Thank You

to the *ROLEX 24 at Daytona* 2011 winners*
and thanks to 77% of the entire field
who used *PAGID RS* race pads.



The logo features a blue square on the left containing a white and black stylized 'P' shape. To its right, the word 'PAGID' is written in a bold, white, sans-serif font, and 'RS' is written in a blue, italicized, sans-serif font.

One, Two overall winners:
Chip Ganassi Racing / BMW Riley

GT class winner:
TRG / Porsche GT3 Cup



TMD
FRICION

bt
Brake Technology

GERMANY
BT Bremsen Technik GmbH
info@bremsentechnik.de
www.pagid.com

USA
BT Brake Technology
pagid@braketechnology.com
www.braketechnology.com

* overall position 1 to 7 for Daytona Prototypes and 1, 2 in GT class, all on PAGID RS racing brake pads.



Rototest
www.rototest.com



Image courtesy of Andretti Green Racing

Powertrain measurements **Redefined**



Flexible & Productive (1Q operation)
Complete vehicle testing with engine dynamometer accuracy
Considerably more cost-effective than traditional test systems



Dynamic & Regenerative (4Q operation)
Full drive cycle capability with inertia simulation
Cutting edge test system for hybrid/electric car development

but running on the road just behind the leaders - the plan being to get out of the pit lane ahead of the leader.

Before the track goes green, cars running behind the pace car but ahead of the leader are waved around the pace car until the leader is the first car in line. You are therefore now back on the lead lap, but at the back of the pack. Now you hope for another yellow coming out soon after the re-start to enable you to come in and top off your tank and hence stay on the lead lap.

However, a short fill is fairly common practice for the final pit stop, depending how close to the end of the race that stop takes place. If you've pitted with only 20 laps to go, there's clearly no point putting in more than 20 laps' worth of fuel, or staying in the pits longer than necessary, losing track position as a result and then carrying unnecessary weight around in the run to the flag. Another reason for saving fuel up to your final pit stop is in order to make this pit stop quicker than anyone else's, and hopefully leapfrog some cars on the way out.

The decision here is whether to take tyres or not, a decision helped by inspecting each set of tyres that come off the car during the race and monitoring your tyre wear. There's a school of thought that says as the track 'rubbers in' during the race, your rate of tyre wear will improve, but I don't think the track surface at Indy really 'rubbers in' at all, as those peaks in the grooves still poke through any deposited rubber and work their cheese grater effect.

If you're lucky enough to be running mostly in clean air and therefore not sliding so much over the track surface, though, you may have an advantage with regard to tyre wear. Should you get within five laps of the finish before your stop, you would most likely turn the 'short fill' into a 'splash and go' and not take tyres.

SET UP

It may not be immediately obvious, but qualifying and the race require significantly different set ups, with downforce level being the main factor.

Qualifying at Indy, as at all US ovals, involves the cars running



Car setup is different for the race and qualifying (top), and could this be the future of pit stops at Indy (above)

alone on track in clean air, on sticker tyres and with a low fuel load. And so relatively low wing settings can be run. Under these conditions, controlling the CoP ie pitch of the car is more relevant than looking after the tyres, so the qualifying set up is on the 'stiff' side.

But running in traffic in the race, especially with worn tyres and at the end of a fuel stint, requires significantly more downforce, maybe as much as 25 per cent more in terms of wind tunnel numbers. A more forgiving mechanical set up is also required, but not one that makes the car 'too comfortable' in traffic, as that will also make it impossible to stay in front should you get into the lead, since the car will be carrying too much aero

drag and hence be slow. Because of all these factors, the correct level of race downforce to run needs to be determined in the practice session.

One strategy is to start the week with the race set up, then switch to qualifying trim as Saturday (Pole Day) approaches. The big decision, of course, is when to switch...

To work on the race set up, you need traffic out on the track willing to work with you (multi-car teams, of course, have the advantage here) and the chassis tuning features that are available during the race will be discussed in the pre-race meetings.

WING ANGLE CHANGE

Help during the pit stops can be provided by wing angle

adjustments (both front and rear can be adjusted at Indy via small t-handles) and is fairly common practice to help fix understeer (add front wing) and oversteer (reduce front wing). These are adjusted by the front tyre changers, as these guys normally finish fitting their new tyres before the rest of the pit crew has completed its tasks.

Adjusting the rear wing is a more convoluted procedure, normally involving the use of a speed brace on a threaded adjuster mounted at the base of the wing pillars. Whatever 'merry dance' is evolved with the mechanics to achieve these changes, the stop will take significantly longer than a stop for only tyres and fuel. And, as we have seen, Indy is now such a track position race that everyone needs their pit stops to be as quick as possible, so rear wing adjustments are now fairly rare.

Tyre pressures can also be adjusted and will, of course, alter the handling of the car, either by changing the dynamic corner weights, 'freeing up' one end of the car, or adjusting ride heights.

Clearly, there is a lot more to this strategy business than just deciding when to pit, but hopefully this will have given you some insight into the equally important 'trackside engineering' that's as much part of the Indy 500 as the racecars and drivers themselves.





Eibach Springs | Quality Unsurpassed

PERFORMANCE PERFECTED

- Ultra-Lightweight for Reduced Unsprung Mass
- Maximum Deflection in Combination with Smallest Block Heights
- Exceptional Block Resistance and Durability
- Precision Tolerances - The Tightest in the Industry
- Precision Planparallel and Square End Configurations Under Unloaded and Loaded Conditions to +/- 1 Degree
- Lowest Side Loads with Load Center Ideally Located Relative to Spring Axis
- Highest Linearity and Guaranteed Rate Consistency Within 2% Of Advertised Rate
- Each Spring Individually Tested and Rated
- Eibach Springs Lifetime Warranty

Eibach produces the finest racecar springs in the world. When other springs sag, or need frequent replacement, top race teams, from F1 to WRC, from Le Mans to NASCAR, inevitably turn to Eibach. And wonder why they didn't choose Eibach in the first place.

To produce springs with unparalleled precision and repeatability, Eibach uses the world's finest Hi-Ten spring steel, produced to exceedingly precise tolerances-according to Eibach specs.

We use world-renowned German CNC coilers, as well as many machines engineered and built specifically by Eibach. In short, we use state-of-the-art technology, in every step of the manufacturing process.

But it's not just about machines and technology: it's about people. Most notably, the Eibach Springmeisters, working at production plants in Germany and the USA: Talented, expert craftsmen, each committed to creating the finest race springs in the world.

www.eibach.com

Germany

Heinrich Eibach GmbH
Phone:+492721 - 5 11-342
eMail:eibach@eibach.de

USA

Eibach Springs Inc.
Phone:+1 951 256 - 83 00
eMail:eibach@eibach.com

China

Eibach Springs (Taicang) Ltd.
Phone:+86 512 53 59 23 88
eMail:fyw@eibach.com

United Kingdom

Eibach UK
Phone:+44 14 55 - 28 65 24
eMail:sales@eibach.co.uk

Japan

Eibach Japan Co., Ltd.
Phone:+81 4 67 61 - 36 10
eMail:eibach@eibach.jp

Australia

Eibach Suspension Technology
P.T.Y. Ltd.
Phone:+61 2-99 99-36 55
eMail: eibach@eibach.com.au

South Africa

Eibach South Africa P.T.Y. Ltd.
Phone:+27 41 - 4 51 53 11
eMail:eibachsa@telkomsa.net





FIRST PRINCIPLES

Simon McBeath offers aerodynamic advisory services under his own brand of SM Aerotechniques - www.sm-aerotechniques.co.uk. In these pages he uses data from MIRA to discuss common aerodynamic issues faced by racecar engineers

Produced in association with MIRA Ltd



Tel: +44 (0) 2476 355000
Email: enquiries@mira.co.uk
Website: www.mira.co.uk

Single-seater details

This month, front end plates, foot plates and flip ups

As we have seen in the previous two issues, the technical regulations in UK hillclimbing offer a great deal of latitude in aerodynamic design. However, one regulatory constraint is maximum bodywork width ahead of the front wheels, which is limited to 1500mm. The overall width across the front wheels of the DJ Firestorm is approximately 1680mm, so the wing width is quite a bit narrower than this. This is more analogous to the pre-

2009 rules in Formula 1, where the maximum front wing width was 1400mm and across the tyres was 1800mm, than to the current rules where the front wingspan is the same as the maximum width at 1800mm. So a new front end plate for the Firestorm, based on

fitted a pair of these end plates to the car early in 2010, the owner / driver Wallace Menzies reported the difference immediately and insisted they stay on the car henceforth, suggesting a worthwhile gain in downforce. The wind tunnel revealed the

flow through the underbody was enhanced

differences, as shown in table 1, below. (Note:

a prototype made by the author in 2005, and that essentially copied the key elements seen in F1 front end plates of that period, would hopefully function well and provide some benefit.

a 'count' is equivalent to a coefficient change of 0.001, so 200 counts = a change of 0.200). For a seemingly fairly small alteration, the change from a flat to this more complex front end



The baseline configuration used simple flat front wing end plates

TABLE 1

	CD	-CL	-CLfront	-CLrear	%front	-L/D
Old end plates	0.768	1.481	0.589	0.893	39.8	1.928
New end plates	0.771	1.778	0.772	1.005	43.4	2.303
Change, counts	+4	+297	+183	+112	+3.64	+375
Change, %	+0.5%	+20.1%	+31.1%	+12.5%	+ 9.2%	+19.5%

TABLE 2

	CD	-CL	-CLfront	-CLrear	%front	-L/D
Change, counts	-10	-17	+26	-41	+1.89	+8
Change, %	-1.3%	-0.9%	+3.4%	-4.1%	+4.3%	+0.4%

change in the numbers, with a sizeable increase in downforce for a negligible change in drag. As expected, there was a downforce gain at the front end, although an increase of over 30 per cent was unexpected. So too was the increase in downforce at the rear, which was a definite extra bonus. Let's speculate on some mechanisms at work here.

First, the span of the front wing elements was made to accommodate the new, wider end plates, while remaining within the regulation front bodywork width. So with the simple flat sheet end plates that the car started with here, the front wing was approximately 200mm narrower than it could have been, at just under 1300mm. However, even if that extra span were present and gave a downforce increase commensurate with the increase in wing plan area, that would not amount to 30 per cent, even allowing for the overall chord dimension of the outer portions being larger than the central portion. In other words, these new end plates were worth more than the equivalent extra span of wing would have been.

FOOT PLATES

It's well known that horizontal 'foot plates' act like deeper end plates and enable a front wing to generate more downforce. The foot plates also see reduced pressure beneath and raised pressure on top, so generate an increment of downforce themselves. Being located just ahead of the front wheels can also see the raised pressure that occurs on the front face of the tyres exerting its influence on the top of the foot plate, too.

But what of the inverted semi-circular section channel running fore and aft along the foot plate, and the hollow quarter cone shape let into the rear, lower part of the vertical face of the end plate? It is thought that the former generates a vortex that

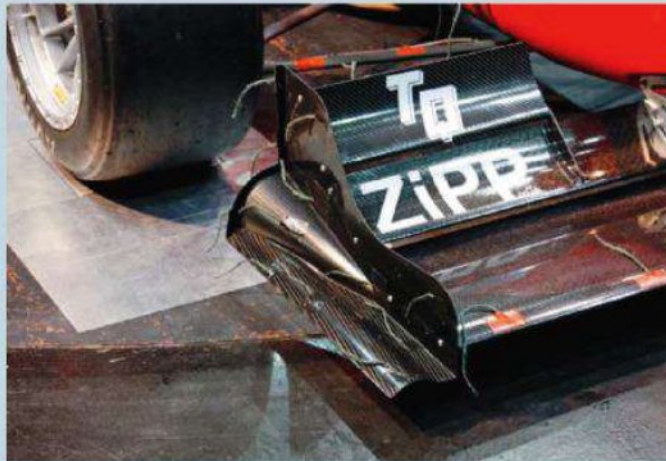

This front end plate design achieved substantial gains, better even than the equivalent extra span of front wing would have achieved



These front end plate flip ups operated similarly to some dive planes on closed-wheel cars, and showed a modest drag benefit

passes along the channel, adding to the effect of a deeper end plate by reducing flow under the wing, and that the latter entrains the tip vortex that ordinarily rolls in under

Then there's the gain in rear downforce to explain. It seems fair to say, as there was effectively no change in drag, that this rear downforce increment did not

the new end plates were worth more than the equivalent extra span of wing would have been

the wing, allowing more of the full span of the wing to function 'normally', less impaired by the presence of the vortex. Again, both of these would add to front wing downforce.

arise from the new front end plates somehow improving the flow to the rear wings, because rear wing downforce increments invariably come with an increase in induced drag. The most probable

alternative explanation is that the flow through the underbody was enhanced or improved in such a way that it developed more downforce with the new front end plates, and because the underbody was designed to concentrate its downforce contribution below the c of g, this increment was spread between front and rear. As such, some of the additional front-end downforce probably also came from the underbody too, and not just the front wing.

FRONT WING FLIP UPS

Another frequently seen device on pre-2009 F1 front end plates was the 'flip up', usually a mildly curved thin plate. But what effect would these have on the Firestorm? Table 2, above, illustrates the changes as they were fitted to the new end plates.

So these flip ups reduced drag slightly and improved efficiency, as indicated by the slight increase in -L/D. They also shifted the balance to the front, should that ever be needed. But overall downforce was reduced slightly, and rear downforce reduced by more than the front increased. So what was going on here? The additional increment of front downforce probably simply came from the flip up acting like a simple inverted wing. The reduction in drag would probably have resulted from the flip up diverting some air over and around the front wheels that otherwise would have impacted on their front faces, and the passage of this air became more efficient as a result. The reduction in rear downforce may have been partly due to the mechanical leverage from the additional forward-generated downforce and possibly also to some modest but adverse interaction with the rear wings. In this respect then, these flip ups behaved very similarly to some of the dive planes we have tested on closed-wheel cars.

More details next month. 

Racecar Engineering's thanks go to Wallace Menzies and all at DJ Engineering Services Ltd.

The **Most** Trusted Name In Racing Clutches

There is a reason the world's top racers put their trust in Quarter Master® driveline products. With the industry's most in-depth testing program and continuous investment in the latest computerized design and manufacturing processes, Quarter Master® always delivers a superior product backed by "racer friendly" product support.

Pro-Series Clutches

The staple of the Quarter Master® clutch line-up, the Pro-Series is proven to offer unsurpassed performance and durability for demanding road racing applications.

- Race-Tested Design Is A Proven High Endurance Performer
- Closed Housing For Strength & Contaminant Protection
- Low Moment Of Inertia & Exceptional Race Durability
- 7.25" Unit Available With Steel Or Aluminum Cover

4.5", 5.5" & 7.25" Dia.; SINGLE, DUAL & TRIPLE DISC UNITS AVAILABLE



SINGLE & DUAL DISC UNITS AVAILABLE

7.25" Rally V-Drive Clutch

A specially engineered version of the race-proven V-Drive clutch tailored to handle the rigors of rally & road racing. This clutch utilizes thicker frictions (.250" thick versus the normal .104") to withstand the punishment of a grueling off-road environment.



Tech & Sales: +1 847.540.8999
quartermasterusa.com

85576



LAMINATING FINAL ASSEMBLY DESIGN SERVICES 5-AXIS CNC LOST TOOLING

FOR NEARLY 30 YEARS CROSBY COMPOSITES HAS BEEN MANUFACTURING CFRP COMPONENTS. OUR CURRENT INDUSTRY SECTORS & COMMON PRODUCTS INCLUDE:

- FORMULA ONE
- WORLD RALLY
- WTCC & BTCC
- GT SPORTS CARS
- AUTOMOTIVE
- SPORTSWEAR
- HOME AUDIO
- ART

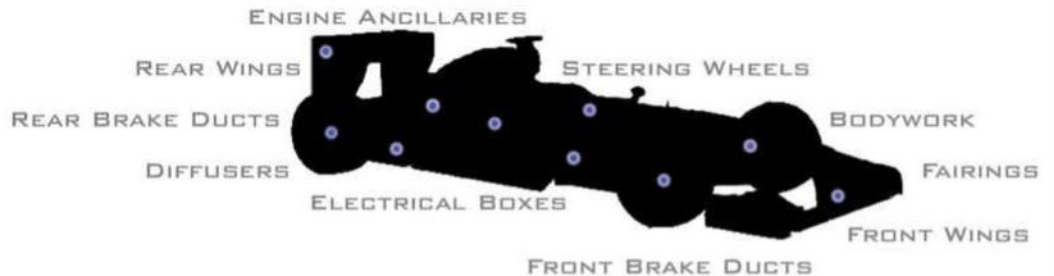

USING THIS VAST EXPERIENCE OF MANUFACTURING CFRP, WE ARE NOW OFFERING OUR DESIGN SERVICES FOR ALL TYPES OF INDUSTRY. SERVICES AVAILABLE ARE:

- DESIGN FROM SCRATCH
- MODEL FROM DRAWINGS
- SCAN PHYSICAL PARTS
- CONVERT SCANS TO CAD
- GENERATE DRAWINGS
- SUGGEST LAMINATES
- PRODUCE TOOLING ASSEMBLIES
- MANUFACTURE



T: +44(0)1280 840630 E: INFO@CROSBYCOMP.CO.UK W: WWW.CROSBYCOMP.CO.UK
 UNIT C, NIGEL COURT, BUCKINGHAM ROAD INDUSTRIAL ESTATE, BRACKLEY, NORTHANTS. NN13 7LF

Investing more in technology

Our technology centre is the most advanced in Europe.

Extreme engineering and precision other performance cam manufacturers cannot match. Like a negative radius of -35mm, giving the fastest valve opening possible. You might not need such extreme technology but it's nice to know that all our camshafts and ancillaries have been developed by the best to be the best.

Nº1

Kent Cams – the best in Europe:

- No.1 for product development expertise
- The greatest performance increase of any single modification
- The widest range of camshaft ancillaries produced on site

The most advanced technology:

- Negative radius to -35mm
- CBN wheels with constant surface speed
- Multi-angle lobes with CNC dressing
- Marposs 3D C and Z axis position probe
- Microphonic wheel dressing
- Lotus Concept Valve Train software



**HIGH PERFORMANCE
ENGINEERING**

www.kentcams.com

Cams + Pulleys, Belts & Chains :: Valves & Valve Springs :: Performance Cam Kits & Valve Spring Kits :: Followers & Tappets

Great things don't change, they evolve.



World Leading BMW Performance



- Vanos Elimination Kits**
- Race Seat Installation Kits**
- Underdrive Pulley Sets**
- Racing Oil Pumps**
- Dry Sump Kits**
- Oil Cooler Kits**



VAC supplies engineered BMW solutions for racing.
With over 25 years of experience, our components have been used successfully in racing cars all over the world.



Online store with over 3000 Products



www.vacmotorsports.com

Tel: 215.462.4666

Phila, PA USA

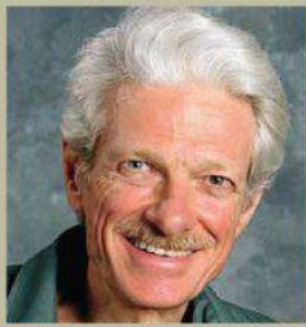

FIRST PRINCIPLES

Mark Ortiz Automotive is a chassis consulting service primarily serving oval track and road racers. Here Mark answers your chassis set-up and handling queries. If you have a question to put to him

Email: markortizauto@windstream.net

Tel: +1 704-933-8876

Write: Mark Ortiz
155 Wankel Drive, Kannapolis
NC 28083-8200, USA

More on Stock Car sway bars



THIS MONTH:

Q Is traction on the inside front tyre reduced by the upward pressure of the anti-roll bar?

A Yes, the bar does unload the inside front wheel and reduce front grip, but no more so than any other method of obtaining the same front roll resistance

While it is illegal in such as the Camping World Truck series to pre-load anti-roll bars at static, teams use unequal anti-roll bar motion ratios on the left and right to fine tune wheel rate and contact patch loads

In V21N3, a questioner mentioned Ron Hornaday's truck being higher on the left after breaking an anti-roll bar (sway bar) arm, and wondered if that would imply the bar was pre-loaded. I said it seemed to me that it would.

Actually, that would be so if the truck was higher on the left when sitting still, and if no pit stops including chassis adjustments occurred. However, if it was only higher on the left on track, and at speed, there is also another possibility. I owe a tip of the hat here to Mike Keena-Levin of Morse Measurements in Salisbury, NC on this. Morse Measurements does kinematics and compliance (K and C) testing, and does a lot more work with top division NASCAR Cup and Nationwide teams than I do. What Mike divulged to me about current bar set ups is evidently so commonplace nowadays that

they do not consider it a breach of confidentiality to share it.

It is illegal in the uppermost divisions to pre-load the anti-roll bar at static, so nobody does that. However, they do use highly unequal anti-roll bar motion ratios on the right and left. This produces some interesting effects, especially when the bar is stiff and the springs soft.

The unequal motion ratios are achieved by using an arm on the left end of the bar that applies its force to the lower control arm at a point further inboard than the right one does. These cars have what is known as a soft link on the left front. Instead of a conventional drop link connecting the bar arm and the control arm, there is a pad that allows the bar arm to lift the control arm, but not draw it down. One reason for this is to keep the bar from de-wedging the car too much if the driver puts a wheel on the apron.

Another reason is to facilitate enforcement of the prohibition against bar pre-loading.

With a bar arm / control arm connection like this, it is easy to have a selection of bar arms with different bends, creating different top-view offsets, that produce a variety of contact points and bar-end-to-tyre-contact-patch motion ratios.

If the motion ratio is dramatically less on the left than on the right, some remarkable things happen when the vehicle is on the K and C rig and the front end is displaced in pure ride (equal displacements right and left, car held level in roll but moved up and down). The wheel rate in ride for the left front wheel can be negative and the load at the contact patch can decrease as the front end compresses. In extreme cases, the left front tyre will actually lift into the air, even as the



bodywork above it is coming down and the overall front tyre pair loading is increasing.

When a set up like this is on track, and subjected to aero or banking loading, with only the relatively meagre rear elastic roll resistance to work against, the car leans to the left under such loading and gains wedge, due to

the action of the bar. If something in the bar system breaks, and the bar becomes ineffective, the car will run higher on the left as it goes around the track. However, it will not sit higher on the left when stationary, if there was no bar pre-load in that condition.

Another thing that could make the truck sit higher on the left,

even stationary, is the adjustment to the rear jacking screws that the crew would likely make to compensate for the broken anti-roll bar arm. The crew would need to put more wedge or diagonal percentage into the vehicle and, in most cases, would use the rear jacking screws to do this, since the fronts are less accessible.

They would need to raise the left rear corner and perhaps also lower the right rear, and this would tilt the vehicle to the right. This would have to happen on a pit stop. If the arm broke late in the race, and the truck did not pit after that, *and* was higher on the left in the static position, that *would* suggest a pre-loaded bar.



Q It seems to me that at full load, where all the car's weight has transferred to the outside wheel, springs and bars would have the same effect. But while in transition, while the outside is compressing, the way the bar resists that compression is by exerting upward force on the inside wheel. Would that not decrease grip on the inside tyre, as long as it would otherwise still have corner weight (downward force) pressing the tyre to the surface?

Here's a scenario: in a vehicle with 1700lb of weight on the front end, 100lb/corner of unsprung weight, 500lb/in springs and 1200lb anti-roll bar resistance, the car should roll one inch when all 1700lb has transferred, but at 1/2in of roll, approx 425lb will still be on the inside corner, and 1275lb on the outside. The inside corner should then be exerting 425lb of force on the inside tyre against the ground, giving it grip. The spring is being compressed by 325lb of corner weight, and so will be compressed .65in by that. The anti-roll bar will then be exerting 600lb of force in the other direction, and so will compress the spring another .83in.

Is the amount of force exerted on the tyre reduced by the upward pressure of the anti-roll bar, therefore reducing the traction on that inside tyre? Is it correspondingly placing load on the outside tyre then?

A The questioner is confused on a number of points. First of all, springs, anti-roll bars and all other inter-connective springing devices are purely displacement sensitive. None of them has any different effect due to the suspension having a roll velocity, they are only sensitive to roll displacement. Dampers create forces that affect load transfer when the suspension has roll velocity, but anti-roll bars and springs do not.

The scenario posited has a number of problems. Conventionally, the 100lb/wheel of unsprung weight is not treated as transferring through the suspension. However, if there is zero camber recovery in roll, the unsprung masses do create a roll moment that the suspension must resist. So for simplicity, let's suppose that the effective mass acting on the suspension in this half-car model really is 1700lb.

If that's so, the weight or load transferred due to cornering is not 1700lb. At most it is the load on the inside wheel so, if the half car is assumed to be symmetrical,



Adding roll resistance at the front increases front but not total load transfer

that's 850lb transferred. At that point, the inside tyre is at the point of impending lift.

If the wheel rate in roll is 1700lb/in (500 from the spring and 1200 from the bar), the half car has a displacement of only 1/2in per wheel at 100 per cent load transfer. Any further roll moment will lift the inside wheel. At half of that load transfer (425lb), roll displacement is 1/4in per wheel. In either case, it would not matter if there were no bar and the spring rate at the wheel was 1700lb/in, the half car would act exactly the same.

The tyres do not know where the roll resistance comes from. They only respond to how much of it there is in total, at a particular instant. The roll resistance may be elastic (from bars and springs), frictional (from intentional and unintentional damping) or geometric (from linkage-induced support forces), but wherever it comes from, it can only hold the car upright by exerting force on the ground, through the tyres. There is a simple, inexorable relationship between roll resisting moment, load transfer and track width:

- Load transfer through the suspension times track width equals roll resisting moment for the wheel pair.
- Roll resisting moment for the wheel pair, divided by track, equals load transfer through the suspension.

This is true, regardless of what part or characteristic of the suspension generates what portion of the resistance. The total roll resisting moment from the front and rear wheel pairs together always equals the roll moment created by sprung mass inertia in response to acceleration. The relative roll resistance of the front and rear suspensions controls the front / rear apportionment of the total, but not the overall magnitude of the total. Adding roll resistance only at the front increases front load transfer, but not total load transfer for the vehicle. It follows then that rear load transfer must be less.

So yes, the bar does unload the inside front wheel and reduce front grip, correspondingly increasing rear grip, compared to the same set up without the bar. However, it does not do this any more or less than any other method of obtaining the same front roll resistance.

killer instincts.

**.2 seconds Quicker
or your money back***

USA 866 392 9936

www.PerformanceFriction.com
motorsportsteam@performancefriction.com

© Copyright Performance Friction 2010.

*see website for terms and conditions.

**PERFORMANCE[®]
FRICTION
BRAKES**

MADE IN THE USA





Call us first...



Unit 31 Silverstone Circuit Towcester Northants NN12 8TN
 T: 01327 857822 F: 01327 858096 www.tridentracing.co.uk



One Company. One Solution

PMI Europe B.V. is located in The Netherlands and the European hub of Performance Motorsports Inc of the USA which owns the brands shown below. PMI Europe B.V also distributes ARP, Cometic and Carrillo to serve you as a one stop supplier.

New!



Innovate Motorsports Diagnostic equipment (AFR-OBD-II)



K1 Cranks & Rods



ARP Bolts & Studs



Innovate Motorsports



Cometic Gaskets



Wiseco Forged Pistons



Carrillo Rods



PMI Europe BV
 Pesetaweg 32
 2153 PJ Nieuw Vennep
 The Netherlands

Tel: +31 (0) 252 680437
 Fax: +31 (0) 252 684643
 Email: info@pmi-europe.nl
 Web: www.pmi-europe.nl



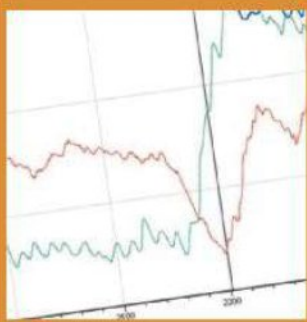

FIRST PRINCIPLES

Databytes gives insights to help you improve your data analysis skills each month as Cosworth's electronics engineers share tips and tweaks learned from years of experience with data systems. Plus we test your skills with a teaser each month.

To allow you to view the images at a larger size they can now be found at www.racecar-engineering.com/databytes

Further maths

More on how advanced mathematics can improve your racecar engineering

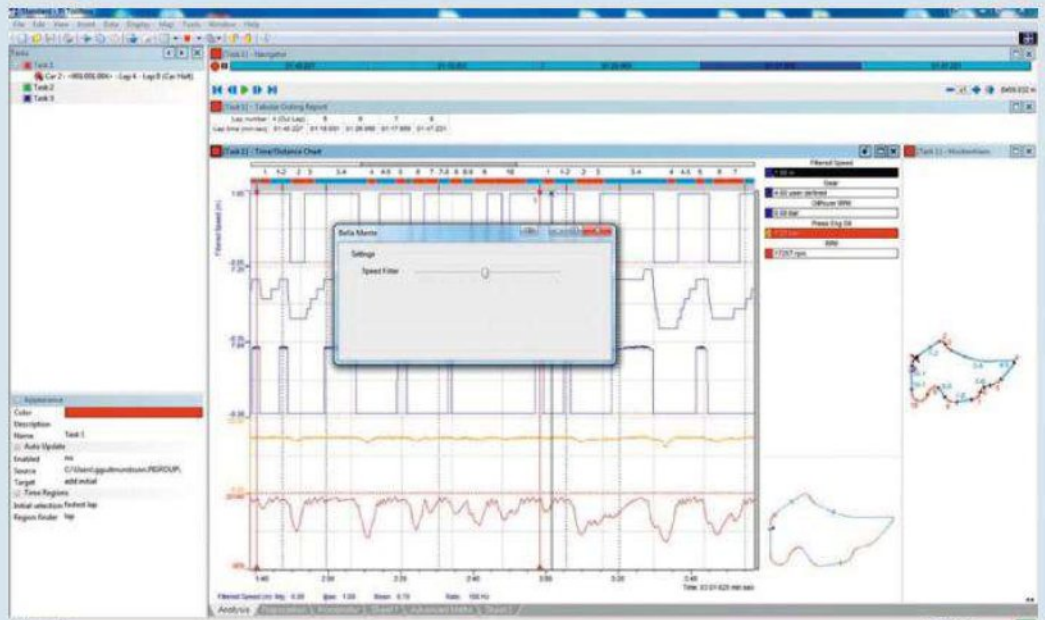

Figure 1: custom control to adjust the severity of a filter

In last month's Databytes we introduced the concept of advanced mathematics and how it is possible to use a specific code file to hold maths channel information, allowing far greater control over the equations, constants and the final output.

However, we can go even further with the advanced mathematic or programmable maths. As with anything that allows program-level access to code, the possibilities for creation are almost limitless. In the case of advanced mathematics, it is not just possible to write equations, it is also possible to create user interfaces and graphics. This, for example, allows the engineer to create a new style of graph, or to create an additional user

interface that can be used to adjust any number of constants.

In the example shown here, we can see a slider control that was created to adjust a custom filter made using advanced mathematics. The ability to completely customise the software like this might not be

program and, as such, if one part of the code is wrong, the whole program will not compile, and none of the calculations will work. This is why it is very important to have effective version control and also look into the possibility of running several different advanced mathematics

if one part of the code is wrong, then the whole program will not compile

for everyone, but it opens up some very interesting options for teams and engineers.

There is one important pitfall that must be considered when using advanced mathematics, however, and that is the fact that it is effectively a computer

code sheets. For example, there could be a separate document for tyre analysis, another for suspension and yet another for aerodynamic calculations. This way the risk of failure is spread and it will be easier to identify any error in the code.

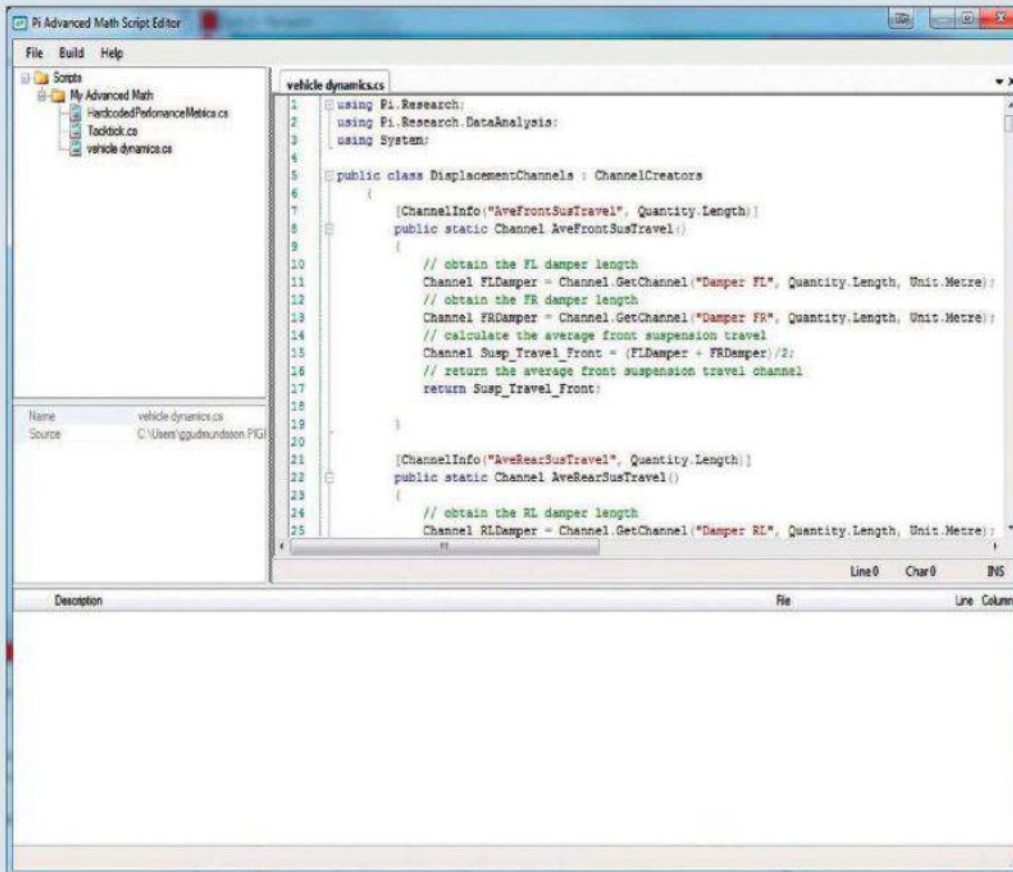

Figure 2: several different advanced mathematics program documents are visible on the left, with the code displayed on the right

The advanced mathematics function also brings some interesting possibilities for sharing and controlling the maths channels in use.

As the equations are stored separately, it is possible to have a central mathematical equation document that is

the maths channels across different vehicle classes, as long as they all have compatible data systems.

Another interesting opportunity to share maths channels like this would be in a one-make series or a series that has a mandatory one-make data

who have limited programming knowledge to still have access to some useful maths channels.

If we continue looking at the situation where a full grid of cars has compatible data systems - for example, where there is a specific scrutineering data system installed in every car - a similar architecture to the advanced maths system can be used to create a very effective scrutineering tool.

By creating a custom program, it is possible to link the mathematical equations to an SQL database and then create a separate user

interface that would flag any instance when a controlled parameter is out of its operating window. For example, if turbocharged engines are being used in a series, the turbo boost pressure limit would be one of the constants and then the user interface would indicate if the vehicle boost pressure exceeded this limit.

it is possible to have a central mathematical equation document that is shared between engineers

shared between engineers in a multi-car team. Not only does this save time and make sharing easy and simple, it also allows the team to keep a good record of any changes and control version history. When this type of sharing system is used, each engineer takes care of his / her own constants, as they may vary between cars and drivers. This makes it possible to share

system. Series' organisers could create an advanced maths channels document that would be available to all competitors. This document could either be distributed as a compiled piece of code, so the competitors can only access the channels in the data but have no access to the code itself, or as an editable document. In this case it is, for example, possible for those

COSWORTH

Produced in association with
Cosworth
Tel: +44 (0)1954 253600
Email: ceenquiries@cosworth.com
Website: www.cosworth.com/motorsport

Bosch, turning all corners into the home stretch

125 Years  Bosch
1886-2011



All components in perfect harmony: Engine/data management, displays, sensors and software – everything from a single source. And all this combined with the development expertise of the world's largest automotive components supplier. We are there for you around the clock, anytime, any place.

www.bosch-motorsport.com



BOSCH
Invented for life



The original CONNECTORS

METICULOUSLY ENGINEERED TO CONNECT

ADEL WIGGINS Flexible Tube Connectors

THE POWER TO SECURE

Stay connected with Adel Wiggins Flexible Tube Connectors! The difference between winning and losing is in the connection. Do not sacrifice a win to a simple hose blowout or burst. This occurs when conventional hose clamps or barbs fail to secure the hose located between the connections or components. Adel Wiggins Flexible Tube Connectors eliminate these failures. This is why so many professional racers today confide in them.

THE POWER OF EFFICIENCY

Adel Wiggins Flexible Tube Connectors are very efficient when it comes down to valuable time sensitive installation or removal. They can be quickly removed and installed with only one hand, whether they are being used with tubing or hose. The locking latch design eliminates troublesome and time-consuming installation of safety-wire or the necessity of tools to make the connection. The electrical bonding feature eliminates the external clamps, fasteners and jumper wire required in some applications. The W900 series minimizes weight and unit cost, while retaining the proven performance and reliability of other WIG-O-FLEX connectors.

GET CONNECTED!

Adel Wiggins Flexible Tube Connectors are offered standard in lightweight aluminum and are available in stainless steel or titanium upon special order. They feature an operating temperature range from -120° F to 800° F and are able to withstand boost and pressure levels in excess of 125 PSI.

CONNECTOR APPLICATIONS:

- Full Engine
- Radiator
- Intercooler
- Oil Cooler
- Turbo & Blower
- Throttle Body

GET CONNECTED!



FCP
Fluid Control Products, Inc.

Australia: Rocket Industries 02 8825 1900 | England: Goodridge UK 01392 369090 • BMRS 0175 355 3610 • Earts UK 0132 785 8221
Germany: Goodridge Deutschland 06321 60168 • Krontec 09401 52530 | Italy: Technauto SRL 02 738 8773
Japan: SiFo Corporation 03 5420 4154 | New Zealand: Turbo Vehicles Ltd. 09 525 6696

Toll Free in NA: 800-541-2345

Worldwide: 217-324-3737

www.fluidcontrol.net

Indy Car 2012

"It is never going to be equal"

With the DeltaWing abandoned, the premier US open-wheel series is back to different engines and a choice of aero kits, but still the name Dallara dominates

BY IAN WAGSTAFF



Motorsport has reached a point where creating a new series has become a catch 22 situation. A spec series offers close racing but is derided by virtually all, while an open formula simply does not make economic sense. The IndyCar Series' administrators are very aware that it is impossible to go back to the type of multi-chassis racing that they once enjoyed but, in trying to create a third way, are having to write the rules as they go along.

'It is essential for us to be on the offence,' says IndyCar Series CEO, Randy Bernard. 'That means having a technical team that can continue to change the bar and keep the engineers on their toes.'

Bernard had asked his advisors, notably the committee appointed under the ICONIC (Innovative, Competitive, Open wheel, New, Industry relevant, Cost effective) name, about how they would define an IndyCar. 'Everybody had the right answer, but there

of exclusive vs non-exclusive.'

IndyCar Series project manager, Tony Cotman of NZR Consulting, points out that what the series has decided to do instead means it is now 'designing and building a car at the same time.' Around

member Tony Purnell who, Barnard recalls, 'was sold on the DeltaWing.' However, he became concerned. If the concept did not do everything it promised, where would that leave IndyCar? It was then that Purnell came up with the idea of an alternative aero kit fitted to a single safety cell design. The cars will be named after the aero kit supplier, not Dallara, the cell manufacturer, leading Cotman to admit that the aero kit rule is '85 per cent marketing ploy', significantly adding that, if it had not been for the fact that there will be engine manufacturer competition, 'it would not work for me.'

Cotman's longest lead time concerned the engine, with its minimum weight and avoidance of expensive materials, so

an alternative aero kit fitted to a single safety cell design

were 15 different right answers,' he says. 'There was no true clarity.' He also recalls a sense of depression after the committee had analysed various proposals for a new IndyCar. 'Our goal was to have three different chassis, but we underestimated the cost

Indianapolis there is perhaps disappointment that a more radical technical challenge has not be laid down, but there is also a willingness to make a success of what has been decided upon. And this is epitomised by the attitude of ICONIC committee



Not the new IndyCar design, but part of a line up of past Indy cars designed to illustrate the diversity of machinery that has tackled 'The Great Race'



the basic architecture for that was decided upon first. The middle of last October was the cut-off date for participation in 2012, with Lotus joining Honda and Chevrolet at the last minute. Cotman admits that he thought after the Chevrolet announcement - at which it was announced its supplier would be Honda's current partner Ilmor - 'that was going to be it, but Lotus flew in under the radar.'

Where Lotus engines are to be made is yet to be announced, although Cosworth would appear to be the logical place, given Kevin Kalkhoven's ownership of both KV Racing (currently sponsored by Lotus) and of Cosworth itself, though Lotus has indicated it may eventually run its own team. Bernard predicts 'a couple more engineer manufacturers in 2013,' and says they 'could be some powerful brands. We had some fantastic conversations with OEMs for 2012, but we ran out of time.'

THE ENGINE PACKAGE

'Apart from [Audi's] Ulrich Baretzky, all the manufacturers we talked to showed more

However the aero kit concepts pan out, one thing seems certain - fans of IndyCar racing will have to accept a change in the style of competition

interest in a twin turbo, 2.4-litre V6,' said Cotman. 'Selfishly, I'd love to see an in-line four, but this is not going to happen in 2012, though one could be accommodated later down the line.' The three baseline power levels originally quoted of between 550 and 700bhp for road, street and ovals are

The three baseline power levels of between 550 and 700bhp for road, street and ovals are being maintained

being maintained, but in January the displacement was reduced to 2.2-litres. While the engine regulations have been given to the manufacturers, they have yet to be released to the public. Likewise, the aero kit parameters have now gone to interested suppliers, but will not officially be announced until nearer May,

Around 80 per cent of the component vendors to the new formula had also been decided by December, but only transmission supplier Xtrac had been finalised. In some cases, there may even be dual sourcing, although the products will have to be identical.

Deciding upon the engine package took all of Cotman's time

until the beginning of November, and it was only then that he could turn his attention to other projects. 'I realise that three different engines are not going to produce the same amount of power. I am not prepared yet to discuss too much about how we will police any difference in engines, but we have approached

it in depth and will monitor many parameters. The engine manufacturers understand our intentions.' The use of turbochargers will make it easier for the governing body to control engine power outputs.

'We must learn from our mistakes. In the past, one engine has dominated and driven the others out of business. I don't think there is anything wrong in having potential deficiency clauses in your regulations. It is how you handle these that we are looking at. You need to have a ceiling on what people can do. It will be wrong if someone is deficient by three per cent and, having been given permission to make changes, they then forge ahead by three per cent. All that does is to force the others to develop. Having deficiency clauses is okay, but I think there needs to be some strict parameters so that we don't have a never-ending engine development escalation.'

The other question arises as to how the fields will be split in terms of engine allocation. 'We have a couple of ideas about this. The first to hear about these will



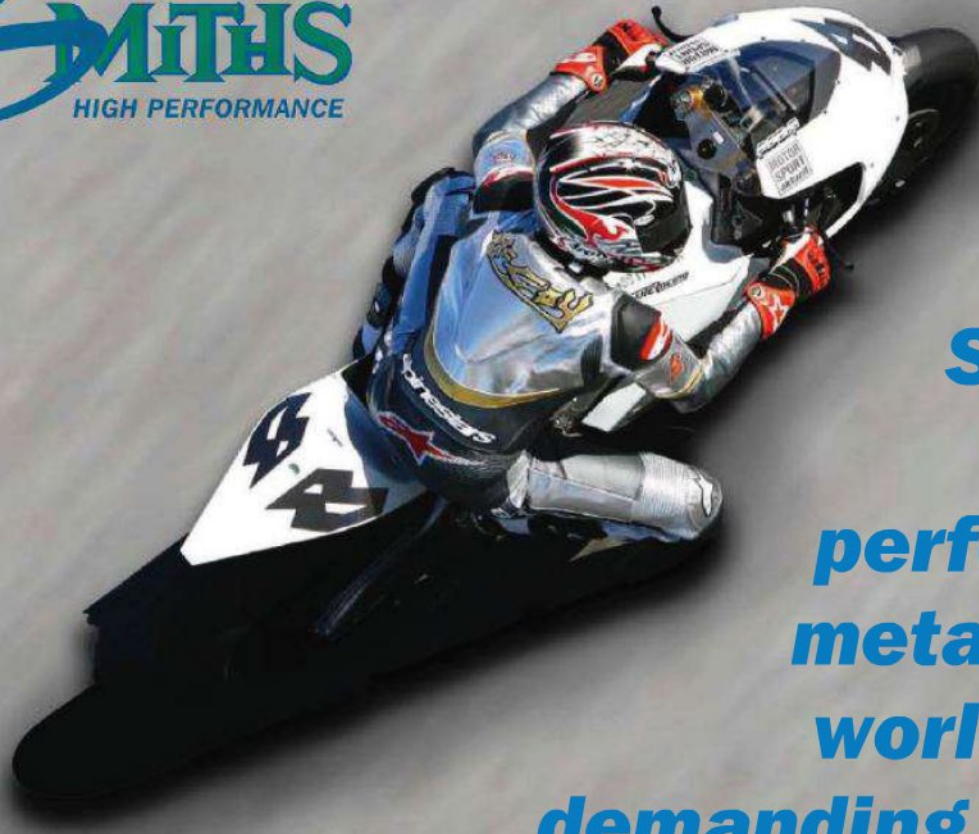

**Stockists
of high
performance
metals to the
world's most
demanding markets**

ALUMINIUM ALLOYS

- **7068**
- **7075**
- **4032**
- **2024**
- **2099**
- **2195**
- **2618**
- **2014**
- **Bar, Plate & Forgings**

Smiths High Performance Unit 0, Stratton Business Park, London Road, Biggleswade, Beds SG18 8QB

Tel: +44 (0) 1767 604 708 Fax: +44 (0) 1767 312 885

www.smithshp.com

competitive
fast
reliable
professional



Your high-performance stockist for:

- Titanium and titanium alloys
- Aerospace-grade materials
- Nickel-based alloys
- Special steels

Application areas:

- Aerospace
- Motorsport
- Medical technology
- Military engineering
- Ultrasonics
- Special purpose machinery manufacture
- Electroplating

Headquarters + warehouse:

Im Grund 5
D-21435 Stelle
+49 4174 6694-0
+49 4174 6694-26

Sales office:

Wertstraße 23
D-40549 Düsseldorf
+ 49 211 230999-0
+ 49 211 230999-26

Email : info@s-dspezialstahl.de

www.s-d-spezialstahl.de

At last - TPMS without the "dreaded" batteries!!!

Stack's unique Tyre Pressure and Temperature Monitoring System (TPMS) has eliminated the electronics and batteries from the sensors, providing new limits of performance for TPMS, and significantly increasing sensor life to 5 seasons or more! We've reduced the first year cost, and eliminated on-going maintenance costs.

- Less weight – only 10g (0.35oz).
- Sampling rates up to 10Hz without reducing sensor life.
- Auto-detect wheel changes without pre-programming.
- Maintenance free - longer life, significantly lower running costs.
- Higher continuous operating temp – up to 150°C (300°F) or above.
- CAN output for connection to existing systems.
- Measures both pressures and temperatures.
- Specialist high sampling rates – up to 40Hz.



**STACK
STACK
STACK®**

To find out more call +44 (0)1869 240404
or visit www.stackltd.com

...when only the best will do!

be the team owners, but we still need to beat this around with the engine manufacturers.' An announcement is expected soon, although it is already known that exclusivity will be banned, preventing such as Penske and GM from domination, despite the fact that the former has brought the latter to the table.

AERO KIT PARAMETERS

The final draft form for the aero kit package had been completed by the beginning of December to be 'mulled over' by interested parties, though the list of suppliers does not have to be finalised until October. 'A lot of the parameters that are going to be placed around the aero kit have not been designed yet,' says Cotman. 'They will be inserted as we move through the build process. We need to get a car up and running by early July and then decide if we need to make any changes from there. That will dictate how quickly the rules get finished for aero kits. We will come to forks in the road and have to make decisions.'

Dallara's US representative, Sam Garrett, says that head designer for the project, Antonio Molinari, and his team 'have been under pressure to design a car that is safe and yet allows other people to come along and dress it up. The aero kit suppliers will be more concerned with performance, but we have to shoulder the load for the safety aspect. The monocoque will look like most monocoques but what will be unique will be what we do to allow people to attach different shapes to it without compromising the integrity.' Garrett reports that the teams seem to have been most concerned about driver comfort and how easy it will be to adjust their cars for different-sized drivers.

The teams will be able to buy a Dallara aero kit when they purchase the Dallara-built safety cell, or they can either make their own or else ask a third party to supply one. The maximum amount they will have to pay will be \$70,000 per body kit. Teams will be able to use two different, homologated versions per year, preventing the larger operations from using multiple kits. It will be



Computer generated image of the proposed 2012 Dallara chassis - 'a car that is safe, yet allows other people to come along and dress it up,' is how the company's US representative, Sam Garrett, describes it

possible to buy a car without the default kit, otherwise this would count as one of the two. IndyCar Series senior technical director, Les Mactaggart, says that the alternative kits should fulfil the same parameters as the default kit and be capable of running at all events, but it remains to be seen whether teams might end up running one of their two choices on the ovals, the other on the road and street circuits.

Until Dallara finalises the design dimensions for the safety cell, though, the exact dimensions for the aero kit cannot be determined. 'These will consist of volume boxes that people will be able to design, such as engine covers, sidepods and front and rear wing assemblies within,' explains Mactaggart. Dallara's initial

and engineers will find a common solution in terms of efficiency. It's physics and you can't get away from that!

SAFETY IMPROVEMENTS

Mactaggart uses the word flexibility when he points out that the eventual design will have to give the aerodynamicists opportunity for originality. Andrea Toso, Dallara's head of R and D, adds that safety will be improved over the existing IndyCar, and this will include measures against interlocking wheels, improvements in aero stability and cockpit accessibility, improvements in the crash worthiness of the front and rear structures and, maybe, use of the F1 roll hoop test. There will probably also be a structure behind the rear wheels

forward.' However, he expresses himself 'disappointed that we don't have a more open formula, that the IndyCar Series has only addressed the desire for innovation with the bodywork and not with the chassis.' Even if it did not choose the DeltaWing, he feels the ICONIC committee should at least have looked at what those behind it were trying to say.

Already it seems that, in addition to the default Dallara kit, there will be alternatives from Lotus and Chevrolet, and more are predicted. 'I am convinced there will be four or five in total,' says Cotman, 'and I think people will be surprised by who is planning to build them. Some of the interested parties are huge companies...'

Says Bernard, 'The goal with the aero kit is to see new money being brought into the sport. It would be good to get major aerospace companies to come in and re-define how we look at aerodynamics.'

Cotman: 'Ultimately, one set of bodywork could dominate, and then everybody would want to use it. We need to stay one step ahead of this. We can evolve the rules over a period of time, allowing for different developments in different areas. The expectation from the teams under the current rules is that they must all have the same thing, yet two of them are currently dominating. Good

there needs to be some strict parameters so we don't have a never ending engine development escalation

renderings suggest that the results are unlikely to look radical. Fans should not be looking for noticeable differences in the appearance of the cars, although Mactaggart says that is one of the objectives. However, he admits, 'form follows function

to prevent the car behind from taking off in the event of contact. 'It's a positive step,' says Mike Hull, team managing director of Target Chip Ganassi Racing, of the aero kit idea. 'We now have a direction from the sanctioning body that will enable us to move

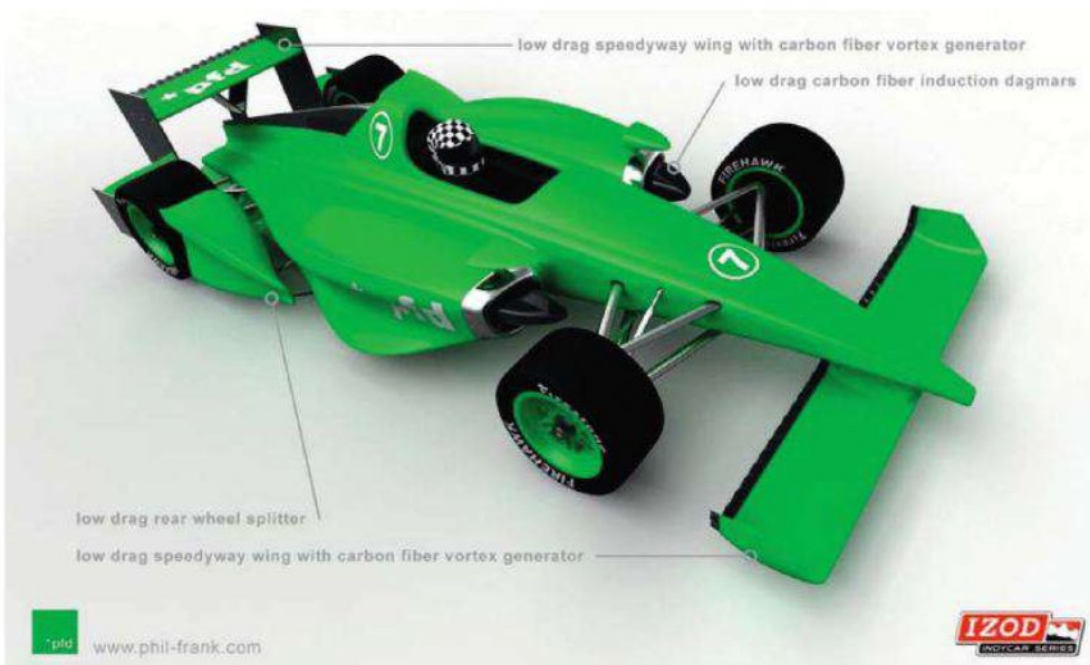

Teams will have the option of buying a Dallara aero kit, making their own or asking a third party to supply one. The maximum spend will be \$70,000 per kit and two different, homologated versions will be able to be used per year

teams are always going to come to the top and I believe that we should not penalise anybody who does a better job than somebody else. We need to be realistic. We need to keep an eye on costs, allow everybody the same set of parameters, while making sure that nobody is going to come out exactly the same.'

THE AERO KIT BUSINESS CASE

Hull predicts that it will cost at least \$1 million to develop an aero kit and that it will not be financially viable to sell enough at \$70,000 each. However, Dallara's CEO and general manager, Andrea Pontremoli, points out that two aero kits should be purchased for each car, believing that there is a business case for somebody who could supply for about 10 cars and therefore sell 20 kits for \$1.4 million. It should be remembered, though, that Hull's figure of \$1m is just the development and not the manufacturing cost. Swift president, Jan Refsdal, observes how different the costs could be if it were a team, or third party, hiring a supplier to manufacture the kit, or a company such as his own producing in house. 'Certain absorbed costs that we have in the business could make it more attractive. However, it's tough to say what will make sense until the rules have been finalised.'

For the OEMs, though, whose ultimate goal is to sell more road cars, or even the conjectured

aerospace companies, this will not be part of the equation. 'The fact that you have to sell the kit for \$70,000 is completely irrelevant,' says former Indy 500-winning designer, Bruce Ashmore. It would make no sense for the conventional racecar manufacturers to produce such kits on their own. However, should the engine manufacturers want the whole car to be named after themselves, then it is to these that they are likely to turn. 'If an engine manufacturer came to Swift, that would be an attractive proposition,' says Refsdal.

“ The goal with the aero kit is to see new money brought into the sport ”

Pontremoli says that his company could supply not only its own aero kits, but also help rival firms develop their versions using Dallara's Varano de'Melegari wind tunnel. Perhaps significantly, Lotus director of motorsport, Claudio Berro, points out that Lotus already has a strong working relationship with Dallara, which assisted on the aerodynamics for the former's Evora Cup car.

Toso observes that there will be four parts to any kit - the sidepods, engine cover and front and rear wings. A manufacturer

will be at liberty to supply all four components or to choose to make just some of them. If the latter is the case, then the remaining components must come from Dallara. As such, it will be quite possible to use a 'Lotus' engine cover with Dallara sidepods, but it will not be possible to mix and match with other suppliers' parts. 'The Dallara kit will be a common denominator,' says Mactaggart. 'If you allow mix and match, there will be so many alternatives that the costs will go out of control.'

So, if use is made of a Dallara kit and just the front wings changed, what will the car be

to design a car that can go faster than the drivers can cope with, and therefore he believes passionately that the sport should come up with designs that work within social parameters. He does not believe that simply offering different bodywork will meet these requirements.

NO COMMENT

Other specialist suppliers are refusing to commit themselves either way until after the regulations have been finalised. Lola executive chairman, Martin Birrane, for example, is known to be examining the situation following the failure of its bid. However, Lola's Sam Smith states that the company is, at the moment, making no comment. Teams could produce, or have produced, their own kits and there has been speculation that some will take advantage. However, reigning champion team owner, Chip Ganassi, is among those who have said they will not comment until they have seen the rules.

Finally, Cotman concludes that, whatever happens, the fans are going to have to expect changes in the style of racing, and that the close racing brought about by having a grid of identical cars will probably be a thing of the past. 'Racing will change. Any time you have multiple manufacturers of anything, it is never going to be equal, but isn't that why we are here?' 

Ferrea
RACING COMPONENTS

Competition

Hollow Stem Valves

LIGHTER | STRONGER | FASTER = MORE POWER

22% lighter than conventional stainless steel alloy valves



Ferrea Racing Competition Plus Hollow Stem Valves are 22% lighter than conventional stainless steel alloy valves. Their proprietary manufacturing process gun drills and micro polishes the bore of the valve stem. These valves are also made from Super Alloy materials which resist heat much better than conventional Inconel materials.



- Friction Welded Tips
- Radial Grooves
- Avionic Chrome Plated Stems
- Seat Hardness up to 42 HRC
- Super Flo Design to Improve Flow
- Available in 5/16, 11/32 & 3/8 Stem Diameters or Semi Finished Blanks

Download your QR Reader app to your smartphone to scan our code for more exclusive information.



FOLLOW US ON:  

FERREA RACING COMPONENTS

Tech Line: 954-733-2505 • Toll Free: 888-733-2505 • www.ferrea.com www.ferreatv.com

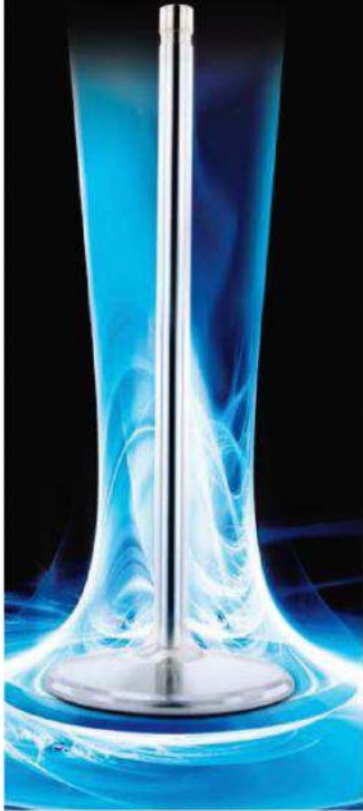

Choice of Champions

www.ProFabrication.com

704.795.7563

PRO FABrication
Racing Exhaust Systems

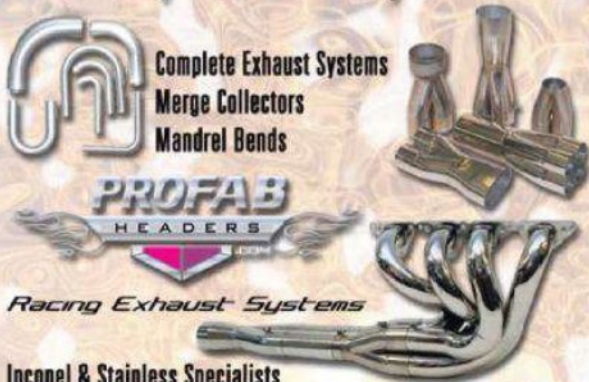

Complete Exhaust Systems
Merge Collectors
Mandrel Bends

PROFAB
HEADERS

Racing Exhaust Systems

Inconel & Stainless Specialists
Cad Capable
Custom Header Builder



There's no such thing as
OVER-ENGINEERING
when your goal is TO WIN!



We may be known for our cooling system solutions but C&R Racing also provides engineering solutions for our customers that improve designs and reduce manufacturing costs. As a long standing leader in design and manufacturing for the motorsports arena, we have the experience to turn ideas into products quickly and competitively for any industry.

- Engineering Services
- Integrated Manufacturing
- Manufacturing and Supply Chain Management

Our focus is to develop a close relationship with you to deliver design and lean manufacturing solutions.

Contact us for your next project!

C&R RACING
INCORPORATED

Motorsports Engineering & Manufacturing,
Cooling, Drivetrain, and Performance Parts
C&R Racing, Inc. - Indianapolis IN - +1 (317) 293-4100
C&R Racing, Inc. - Mooresville NC - +1 (704) 799-0955
www.crracing.com

OBR

Control Systems

WHY FOLLOW WHEN YOU CAN..... **LEAD**

1ST 2ND 3RD

IN 2010

LE MANS 24 HOURS

OBR technology was also used by cars finishing 4th, 7th and 9th, taking victory in the unofficial LMP1 Petrol class as well as 2nd and 4th in LMP2.



Specialising in engine / power management systems and a complete range of data logging, displays, sensors, actuators and wiring

Ole Buhl Racing (UK) Ltd is a world leader in the supply of motorsport electronics. Our range of innovative products are used in the world's most demanding environments ensuring performance and reliability.

WWW.OBR.UK.COM

AERODINE COMPOSITES GROUP



ADVANCED COMPOSITE TECHNOLOGIES
FAA CERTIFIED REPAIR STATION RDMR624X

- STRUCTURAL COMPOSITE ENGINEERING
- PRODUCT & TOOLING DESIGN
- CAD/CAM
- FINITE ELEMENT ANALYSIS
- PROTOTYPING
- MANUFACTURING
- STRUCTURAL REPAIR

Serving the Motorsports Industry Since 1989

www.AerodineComposites.com

Tel. +1 001.317.271.1207 • Fax. +1 001.317.271.4455

8201 Indy Lane, Indianapolis, IN 46214

DOCKING

Advanced Cooling Systems

Water Radiators
Intercoolers
Oil Coolers
Heat Exchangers
System Design
Ancillary Products

Manufactured to your requirements by the UK's leading supplier.

25
YEARS
SERVING MOTORSPORT SINCE 1984

Tel 00 44 (0) 1327 857164

Fax 00 44 (0) 1327 858011

Website www.dockingengineering.com

Unit 15 Silverstone Circuit • Silverstone Northants • NN12 8TL • United Kingdom

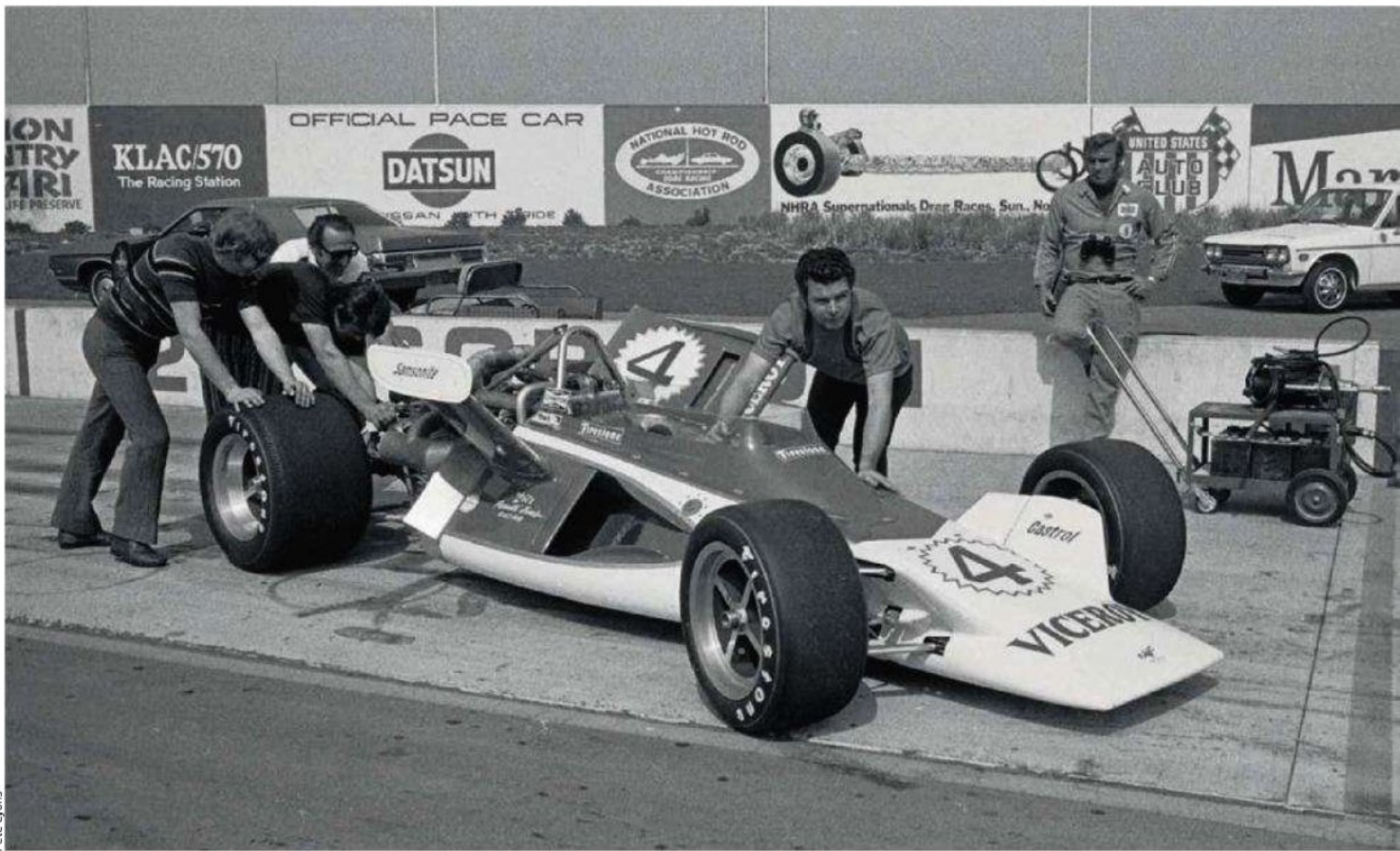

Pete Lyons

A step too far

The Vel's Parnelli Jones VPJ1 Indy car generated considerable excitement on its 1972 debut. As it transpired, however, the radical looks flattered to deceive

Before becoming a team owner with business partner Vel Miletich, Rufus 'Parnelli' Jones was a renowned racing driver who won the 1963 Indianapolis 500 and was less than 10 miles from a second win in 1967, when a transmission failure stopped his STP Paxton gas turbine car. Two years after Jones retired from circuit race driving, a Vel's Parnelli Jones Racing Team (VPJRT) Colt-Ford turbo driven by Al Unser won the Indy 500 in 1970, and the team and driver repeated the feat in 1971. For good measure, VPJRT driver, Joe Leonard, also won the USAC National Championship in 1971. With increased financial support from Firestone tyres and the Brown & Williamson tobacco company,

BY ALAN LIS

through its Viceroy cigarette brand, Jones signed driver Mario Andretti to race alongside Leonard and Unser in 1972, and hired Maurice Phillippe, who had recently left Team Lotus, to design an all-new chassis for his 'super team'.

For the Parnelli VPJ1, Phillippe adopted an adventurous design philosophy, the most outlandish feature of which was an aerodynamic approach that employed large dihedral aerofoils mounted alongside the cockpit and smaller versions incorporated into the bodywork between the front wheels.

In a 1972 interview in *Machine Design* magazine, Phillippe is quoted as saying, 'The primary purpose of the

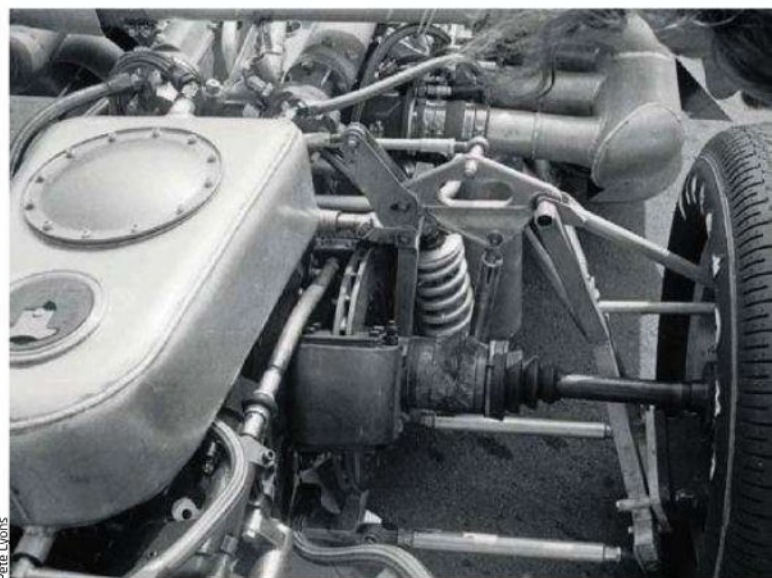

Pete Lyons

Camber compensators - first used by McLaren in 1971 - were initially fitted but discarded after the VPJ1's first test. The oil tank located above the gearbox in this picture was later moved to the left side of the engine

**“Our objective -
to consistently satisfy
motorsport’s demand
for the best connection
system, bar none.”**

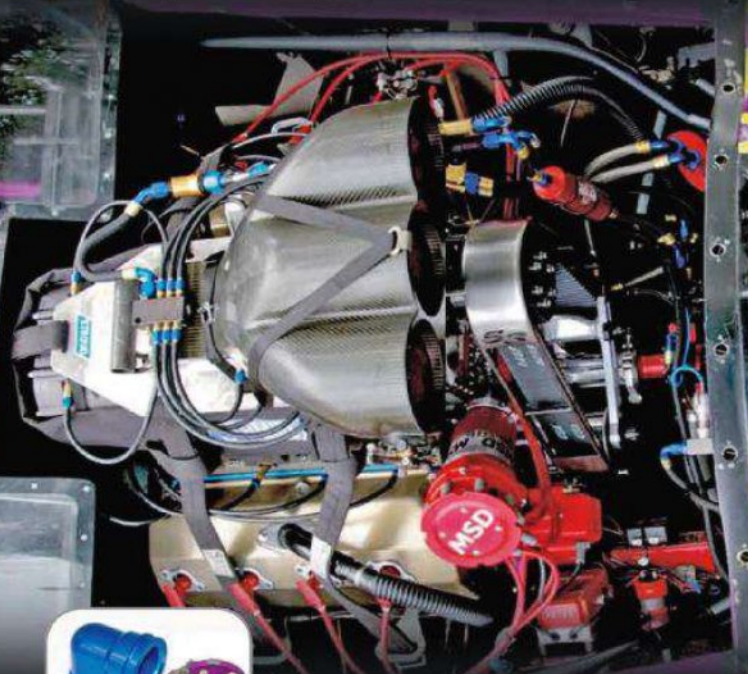

• **2008 Champions use BMRS hose:**

NASCAR Sprint Cup, Truck, Nationwide Owners, Grand Am GT, USAC Silver Crown, Hooters USAR, ASCS National and Mid-West, Knoxville & Williams Grove Track, Rally America, European FIA Top Fuel Champion.



• The lightest hose and fitting combination available



- Crimp and reusable hose end options
- Excellent bend radius - less hose used
- All one piece ‘billet’ fittings, no brazing
- Four exterior braid options



- Custom CNC tube bending service
- Engineering design service - part of your team

Brown & Miller Racing Solutions



Professional Race Hose & Fittings

www.bmrs.net

USA: BMRS Concord +1 (704) 793 4319
UK: BMRS Slough +44 (0)1753 545554



DESIGN • FABRICATION • RACING SERVICES

Clients in Formula categories, LMP and Rally find consistent value in our component manufacturing services for prototypes and short-run production. We seamlessly combine CNC precision with traditional fabrication techniques to produce high value, high performance parts.



Championship winning Ohlins racing dampers custom built for any application supported by a full testing and service facility, complimented by Hypercoil chassis springs and hydraulic perches.



Exclusive North American agent for Farrington Instruments. Contact us for details about their range of superb race car data acquisition equipment and analytical tools.

00 1 413 256 0861 Amherst, Massachusetts, USA www.snapdragonms.com

Contact: Gordon Riseley
email: griseley@ringspann.co.uk



High Performance

Motorsport

Gearshift & Throttle Cables



www.RCScables.com
Tel 01234 342511

RCS - Cables and Controls



Pete Lyons

In addition to their aerodynamic deficiencies, the drivers also hated the dihedral wings because they restricted lateral vision and made it constantly feel as if another car was running alongside

[dihedral] wings is to help us get through the corners faster. They weren't meant to contribute much downforce on the car; they are not efficient in this respect because they also produce a horizontal component. It's the asymmetric effect in cornering that we are after.'

Team owner, Parnelli Jones,

recalls, 'If you were up high in the grandstands in turn one at Indianapolis and looked down on a car going through the corner you would see that even though it was understeering, the back end of the car would still be hanging out a bit. Maurice's idea was that as the car got more and more sideways in a turn,

the angle of the dihedral wings would release the right side of the car and increase the load on the left side on the inside of the corner, effectively helping to hold the car in the turn. That made sense to me.

'Maurice kept talking about yaw, so I guess he thought the car would be going sideways

through the corners,' says Mario Andretti, 'and since all the corners on ovals are left handed, the left side plane would be very active in putting enough pressure on the chassis and the centre of gravity to give the desired downforce.'

In late 1971, Phillippe's theory was put to the test in a one-third scale wind tunnel test programme carried out in the GALTIC 10ft tunnel at the California Institute of Technology (CalTech) in Pasadena.

Although originally built in the 1920s, the GALTIC tunnel was capable of generating wind speeds of 200mph, and the results of the tests were sufficiently encouraging for the full-size car to be built, with the intention that it would race only with dihedral wings.

As news leaked out about what VPJRT was planning, great anticipation built up during the early months of 1972, ahead of the VPJ1's launch, which would take place at a specially organised test at the Ontario Motor Speedway (OMS) in California.

A two-and-a-half mile, four-corner super speedway, OMS

PARNELLI VPJ1 - INNOVATIVE FEATURES

➤ The construction of the VPJ1's unusual, triangular section monocoque followed contemporary practice with the tub being formed of aluminium sheet riveted and bonded around fabricated aluminium bulkheads. A water radiator was mounted in either side of the tub, their leading edges raised slightly from horizontal, with air fed to them by large NACA ducts sunk into the sides of the monocoque section.

When fitted to the car, the rearward dihedral wings were mounted on either side of the cockpit on thin wall, tubular 4130 posts. While the front section of each wing was fixed, there was an adjustable flap at the rear. In addition to their aerodynamic function, the dihedral wings were also used to house the engine oil coolers. 'I didn't like that,' says Dilamarter. 'If there was ever in accident and the wings hit the wall, there would be 230degF oil flying

around. Also having the oil, lines and coolers up by the driver's head raised the centre of gravity.'

'After losing the dihedral wings, the oil coolers were relocated behind the water radiators and we had to add cowls on the tub to feed air to them. To help the air exit, small flaps were added behind the water and oil radiators to create a low pressure area that would

the dihedral wings were also used to house the engine oil coolers

pull the air out. They worked well and we never had any cooling problems with the cars.'

The VPJ1's front suspension bulkhead was a complex piece, which formed two pillars to which the front suspension links were attached and also housed the pushrod-operated, co-axial coil spring and damper units.

Some sources claim that the VPJ1 was originally equipped with torsion bars, but Dilamarter refutes this: 'Unequivocally, that car had coil springs, not torsion bars. What it did have was rising rate suspension and camber compensators at the rear.'

'The principle of the camber compensator was to try and change the camber of the rear wheels in cornering. On an oval

diabolical to drive. The camber compensators were the first things that were thrown away.'

In Dilamarter's view, the use of rising rate suspension was another addition that wasn't necessary on the VPJ1. 'It was way too complicated and not needed on an oval track,' he says. 'On a big, smooth super speedway, the attitude of the car barely changes. The driver doesn't make hard use of the brakes so there's no violent shift of weight at the front or rear. You have centrifugal force, but you definitely don't have the sudden movement that you'd have in a road race car from violent braking, acceleration or changes of direction.'

'Our in-season development work on the VPJ1 was, bluntly, to simplify things, and one of the main things we did was negate the effect of the rising rate rear suspension. All it really did was add weight to the car and make it complex to set up.'

track, ideally you want the left side rear wheel to have positive camber and the right side rear wheel to have negative camber. On the VPJ1 there were camber compensators on both sides, but they didn't work.'

'The net result was that the car wouldn't roll at all,' observes Andretti. 'That made it



Pete Lyons

Pete Lyons

A characteristically messy Offenhauser engine installation would not have been a problem if the VPJ1's dihedral wings had worked as intended. Ahead of a conventional rear wing, though, it called for a steeper angle of attack

was effectively a replica of the Indianapolis Speedway, save that the track was slightly wider and featured banking on its short straights, which meant that lap speeds at OMS were typically a few mph faster than at the Brickyard. Chassis VPJ1-001 was at OMS on March 9, where Mario Andretti and Al Unser were scheduled to run it for the first time before telling the gathered press about it.

'There was a bit of an argument between Al Unser and I as to who would drive first,' recalls Andretti. 'In the end, Al took the car out first, warmed it up,

accelerated a bit and then brought it into the pits and got out. When he said to me, "Okay, Mario, you go for it," my reaction was, "What?"

'Then Al said, "Just be careful..." "So I went out and almost lost it the first time I tried to accelerate on the short chute between turns one and two on the very first lap. There was such a forward bias on the car that it was almost impossible to drive. I came into the pits and told the team PR guy that we had to call the whole event off. The car was not anywhere near ready to do fast laps. We had nothing to talk to the press about.'

DEEP, DEEP TROUBLE

The scale of the VPJ1's problems was apparent from Andretti's best lap at OMS, which was at an average speed of 165mph. A few days earlier, Bobby Unser in the latest Eagle had lapped the track at 196.9mph.

'At the Ontario test, we had two of the best drivers on the planet driving the car and even though they didn't want to say too much, I'm sure that within two or three laps they knew we were in deep, deep trouble,' says Jim Dilamarter, Al Unser's chief mechanic in 1972. 'That was very disappointing because as a team

well short of his elder brother's 191.2mph lap in the Eagle. The dihedral wings were taken off the VPJ1s and were not used again.

In its first three races, the VPJ1 was outclassed by the rival Eagles and McLaren M16s. 'Even with the dihedrals removed and running with just front and rear wings, the car wasn't any better,' recalls Al Unser. 'In 1972, we were running a lot of boost in our Offy engines so we had a lot of horsepower, but we still couldn't match the front runners for speed because the rear wings we used were very large and we had to run them at a steep angle.

MAURICE PHILLIPPE

➔ In the 1950s, British-born Maurice Phillippe was an early member of the 750 Motor Club, which in those days encouraged its members to build and race their own cars. One of Phillippe's competitors was Colin Chapman, who would later found Lotus Cars and eventually employ his rival as chief designer. Phillippe played an important role in the design of the Lotus 49, 63 and 72 Formula 1 cars and the Lotus 42, 56 and

64 USAC Indy cars. At Vel's Parnelli Jones Racing, Phillippe designed USAC and Formula 1 cars in California before returning to Europe, where he eventually became chief designer at Tyrrell in 1977. Phillippe's 008 and 011 designs scored the last Formula 1 wins for the UK constructor and he remained at Tyrrell until 1988. In 1989, he was working on the March Alfa-Romeo project when he took his own life.

“ there was such a forward bias on the car it was almost impossible to drive ”

we had worked our arses off from November 1971 to when the car was rolled out in March '72.'

Three VPJ1's were sent to a test at Indianapolis in early April where they were equipped with conventional front and rear wings, in addition to the dihedral wings. Despite the belt and braces approach, Al Unser's best lap of 183mph in a VPJ1 was

That gave us a lot of downforce, but even then the car didn't feel stable and the steep wing angle also meant we had a lot of drag.'

Despite odds seemingly heavily stacked against it, VPJRT turned its season around with the VPJ1. At Michigan, Joe Leonard scored an unlikely win that was inherited two laps from the finish when the race leader





World leaders in the manufacturer of high performance drive-line and steering rack components, since 1965



COMPLETE GEARBOXES
5/6-speed sequential, H-pattern, heavy duty, dog engagement and synchromesh

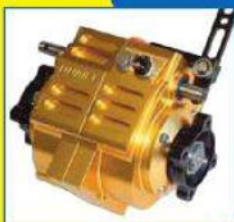

GEARKITS
4/5/6-speed synchro, helical, semi helical, straight cut and dog



DIFFERENTIALS
350 fitments – all with Life Time Warranty



COMPLETE AXLES
axle kits, half shafts



COMPLETE STEERING RACKS
quick racks, rack & pinion kits

PLUS
uprights, transfer units, reversing boxes, motorcycle gearkits

And much more for all types of vehicles

See our web site for more info and order on line at www.quaife.co.uk For FREE brochure: Tel 0845 1307400 / 01732 741144 or email info@quaife.co.uk

Motovicity

DISTRIBUTION
Motovicity Distribution
248-307-1570 phone
248-307-2573 fax
888-SPEED-16



Experts in analysis.

Racing smart means knowing all about vehicle and driver performance. Get the complete picture with integrated data and video solutions from MoTeC - developed with professional teams worldwide and supported by our global dealer network.

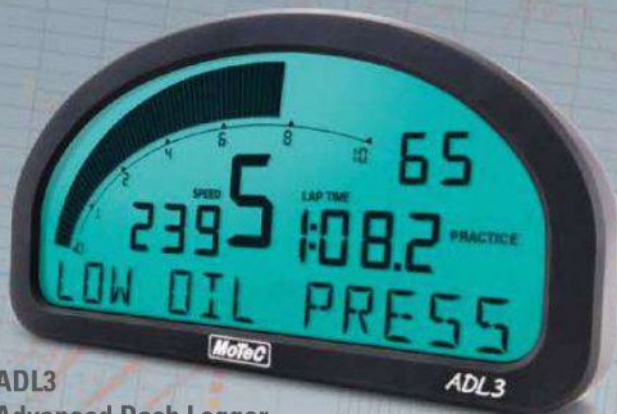

ADL3

Advanced Dash Logger

Programmable display, logger and controller in one. Up to 250Mb logging memory, fast ethernet download, advanced maths, two independent CAN buses and an internal 3-axis G force sensor.



NEW
Automatic CAN
synch of data &
VCS video in i2
Standard



VCS Video Capture System

Solid state digital recorder specially designed for motor sport with programmable Auto Start/Stop, selectable gauge sets, CAN connectivity, 4GB or 16GB, USB download and 12 V power.



Race smart.
www.motec.com

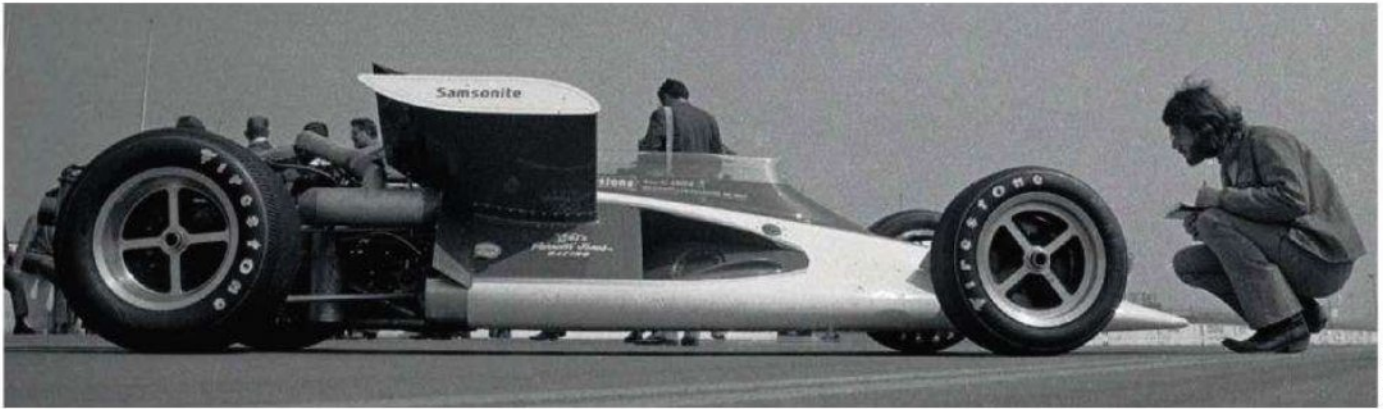

Pete Lyons

had to pit for fuel. He promptly went on to win the next two races, at Pocono and Milwaukee and, by the end of the season, had secured a second successive USAC title.

'Developing the car was an interesting exercise,' says Andretti in hindsight. 'In a nutshell, the more we moved in a conventional direction with the car, the faster it went. Then, as we learned more about proper spring rates and damping, the car improved.'

'VPJRT won a lot of races using the KISS principle,' says Dilamarter. 'Oval track racing is

very simple, but unfortunately, Maurice brought a lot of complicated Formula 1 thinking with him. If there was an easy way and a complicated way of doing something, Maurice inevitably chose the complicated way, much to our chagrin. That was one of the reasons why [crew chief] George Bignotti left the team. George had strongly held views on how a car should be and they were not what Maurice had in mind. George was right, though - you can't make an oval track car complicated - in fact, you can't make any racecar too complicated.'



IMS Photo

Following a test at Indianapolis with both dihedral and conventional wings, the rearward dihedrals were removed. Mario Andretti recalled, 'When the dihedral wings were taken off, the VPJ1 began to feel like a proper racecar'

VPJ1 - A 2011 REAPPRAISAL

Racecar Engineering asked Dr Mark Handford, who has worked on IndyCar aerodynamics for more than 20 years with Lola Cars, Swift and Newman-Haas Racing, for his assessment of the Parnelli VPJ1.

'The dihedral effect on an aircraft only really concerns roll stability,' he says. 'On a racecar, which will not see more than two degrees of roll, it's irrelevant. In my view, what the VPJ1 has is a pair of wings that happen to look like dihedral wings on aircraft, but I don't think they were intended to address a lateral stability issue. I think they were purely about generating side force.'

'The problem is that they would only see an angle of attack that would generate a side force and help the car to corner once it had started to slide, but a driver wants a confidence factor that comes with more and more grip as the slip angle increases. The side wings on the Parnelli look like a sluggish mechanism for generating side force. Building up

the necessary circulation around the wings might take 30-100 milliseconds. A wing used in that way wouldn't give the driver any sense of security.

'An aerofoil tends to generate its centre of pressure roughly a quarter of the cord length back from its leading edge, so although the "dihedrals" on the Parnelli seem to be positioned towards

this arrangement might have generated more side force on the front dihedral than expected

the rear wheels, their location may have positioned the centre of pressure too far forwards.

'With forward and rear dihedrals, the car effectively has a canard arrangement of a main plane and a fore plane so there are two discrete devices that can generate a side force. While the plan area of the front dihedral is quite a bit smaller than the rear

one, it could be as effective, if not more so, because it's in cleaner flow that would be somewhat accelerated as it goes around the wheel. Adding that to the fact the rear dihedral would be operating in the wake of the front dihedral, it's possible this arrangement might have generated a lot more side force on the front dihedral than was expected.

'On a track as fast as Ontario, the drivers would have wanted a car with a very secure rear end, but to me it appears that the side force that the dihedrals generated was too far forwards and it spooked them. After that, the drivers just won't drive the car to the limit. Conventional wings were added later, but I don't think this "belt and braces" approach would

have made things much better, because the wake from the side wings would have badly affected the flow onto the rear wing.

'Adding camber compensation to the rear suspension was just compounding the problems. Maurice [Phillippe] had done some race driving, so he was aware of what a racecar feels like, but I don't think he would have been aware of how stiff the rear of the car needed to be in its response, especially on a high-speed oval. The slightest degree of side slip on the rear should generate a reassuring response. On a graph of lateral force vs lateral movement, what you want is a straight line indicating a nice linear relationship between side force and side slip. What the drivers of the VPJ1 - with active camber control and a side force-producing aerodynamic device - would have got was a big lull.

'Drivers always want to feel a response and the VPJ1 in its original configuration just wouldn't have given them that.'



NEXT GENERATION DATA ANALYSIS



- > Race proven systems
- > Very high data rates
- > Fully customisable
- > Analysis software included



www.gems.co.uk



ACCRALITE
performance forged
pistons

A DIVISION OF



ENGINEERED TO PERFORM
world leaders in high performance pistons

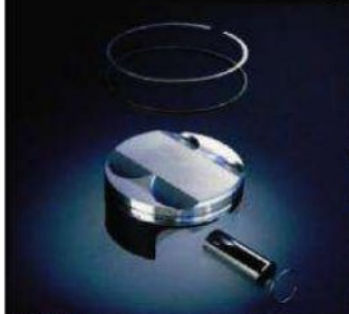

**MANUFACTURERS OF WORLD CHAMPIONSHIP WINNING PISTONS
FOR MOTOGP, WORLD SUPERBIKE & SPEEDWAY. WE POWER
WINNERS IN THE AMA, LE MANS, BTCC AND MANY MORE...**



Omega Pistons

Oak Barn Road, Halesowen
West Midlands B62 9DW

Tel: 0121 559 6778

Fax: 0121 559 6779

info@omegapistons.com

www.omegapistons.com



Open all hours

Ben Bowlby on how open source could be the answer to keeping motorsport relevant and at the head of the technology race

Racecar designer, Ben Bowlby, is a sceptic of spec racing's value at the higher levels of motorsport. When he proposed the DeltaWing Concept for the 2012 IndyCar Series he needed a way to ensure that development and innovation could thrive, while at the same time providing a solid return on investment for all those involved. A lateral and open-minded thinker, he proposed an 'open source' policy as a modern solution to these requirements.

It is now a matter of history that IndyCar's ICONIC committee rejected DeltaWing, although

BY IAN WAGSTAFF

Bowlby is intent on ensuring the ideas behind it are far from dead. Open source development and production gives free access to the end product's source. It has gained momentum with the rise of the internet and is now increasingly being used by industry - so why not motorsport as well, he asks? The new media revolution becomes an ally, transcends just the one design and is a possible means of overcoming the sterile thinking behind many current formulae.

In Bowlby's thinking, the entire design of the initial version

of the car is published on a dedicated website, which offers unrestricted access and is free to everyone - teams, manufacturers, students, fans - and anyone can submit new designs for approval. Before any parts can be sold, however, the supplier must be licensed by a managing entity, eg DeltaWing, and only approved parts with published designs may be raced, with the maximum price of the parts being limited by the price of the original components.

Bowlby admits the idea is a complex one, as it does not intuitively make sense to anyone who has grown up in racing over the past 30 or 40 years.

Traditionally, he points out, suppliers have made money by having the intellectual property (IP) or a patent and stopping anyone else moving in on the business. The post-silicone chip world is moving fast, though, and the rate of technology growth has become critical for competitiveness. If you cannot improve your technology faster than your rivals, you will be swallowed up. Bowlby's question then was, how can that pace be maintained in a sustainable way without financial disaster?

In the computer world, open source has evolved out of necessity. Groups of

“ a possible means of overcoming the sterile thinking behind many current formulae ”



Former Lola designer, Ben Bowlby, is now head of engineering for Target / Chip Ganassi Racing and was the man behind the radical DeltaWing IndyCar concept (left)



people combined their activity to generate more powerful software, which was then used to generate other products that would make profits. The software itself did not generate income. If you can face disclosing and sharing your source material, you then have the opportunity to have many brains and motivated groups develop and use it. An example is Linux, a carefully managed open source operating system that has become extremely powerful - the internet itself runs on Linux - and has not been developed specifically for one corporation to knock out another. In CFD, the open source

software OpenFOAM, which was used for DeltaWing, is gaining popularity and is already being used by major players such as Audi. It is free, powerful and constantly being developed, primarily by those actually using it. The producer, OpenCFD, makes money training people to use it rather than from the code itself, knowing those people will ultimately help to improve it, too.

SIX BILLION DOLLAR MEN

A totally different example used by Bowlby concerns the owners of an apparently defunct gold mine who published the geographical data of the mine.

Around 1400 people made potentially workable suggestions, 800 of which were successful, and another six billion dollars was pulled out of the mine, illustrating the devastating efficiency of collective effort.

'If we have the objective in racing to develop highly relevant, future technology - such as we could if motorsport were not confined by the rules - going open source would enable us to do it in a way that would be highly effective,' he says.

There are already examples of such knowledge sharing within motorsport, such as the 'NASCAR garage system', but Bowlby

believes this is just the start and that it would be exciting to share information far more widely and engage students, universities, suppliers, teams and the entire automotive industry, including OEMs, Tier 1s and Tier 2s.

Not only does sharing push forward development, but it reduces redundant duplication, too. The Formula 1 f-duct, for example, was a brilliant exploitation within the regulations, which was then duplicated by every team, all of whom had to spend vast sums developing their own version of it. In the end, the f-duct was banned, and the industry has

nothing to show for the time and money consumed.

Bowlby says that you could argue the original design of the DeltaWing was that of a spec racecar. Spec racing may be low cost, but it is also low value, missing 'the value' that can found in the brains of the clever people who can be found in racing. How, he asks, do you allow development in a series where the value needs to be high and everybody is concerned about the costs?

THE CLAIMING RULE

Some race series, he observes, have a 'claiming rule' to control costs, where a competitor can 'claim' the engine from a winner's car for a price pre-set in the regulations. However, in a situation where one person does most of the winning, they would have to keep selling their engines. With open source, all the designs are published and given away, though the parts themselves are subject to copyright, so the other competitors could, if they choose, buy, or manufacture under license, those same components for their own use. Using this thinking, the DeltaWing team believed that they had a viable and scalable business model. If a large number of companies became involved, they would take a cut of each part that was sold. If fewer parts were developed, the business could

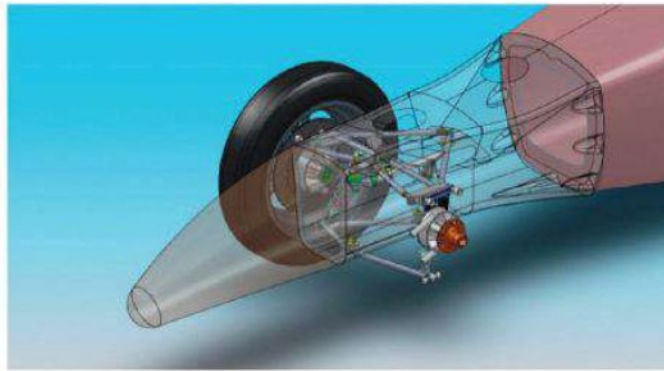

In open source thinking, a list of all accredited parts would be available on a dedicated website. Solid models, design drawings, even supplier names and lead times, could be downloaded for free, a fee only becoming necessary if / when the part is validated for racing

simply be handled by less people.

There is much that can be done using new media that can be applied to this process. The dedicated website, for example, would contain a register of all the accredited parts, including the solid models and design drawings, the part numbers, the supplier, the lead times and costs. This information could then be downloaded at no charge by anyone signing on to the terms and conditions. There would be nothing to stop someone manufacturing a sample part or a team using a part in a test - a fee would only be necessary once the part was validated for racing. In this way, a new supplier could try out whether it was actually capable of making a better / lower cost part.

Any published part manufactured by a company that has been granted a license to supply it for racing could then be sold through the managing entity. When the part had been manufactured it would go for QA inspection for conformity to

design, and be given a unique identifier and serial number. To finance the business, the managing entity would charge a fee for managing and supplying the part, while a royalty would be paid to the design's originator.

In the DeltaWing embodiment, it was the intention that the

Identification) tag. It would be the team's task to ensure that every part used in the car's build was inspected, identified as having been made to a published drawing, and then loaded onto the tag by the managing entity.

To ensure compliance, race inspection might randomly require parts from cars post-race, in which case the parts' identifiers would be scanned and, in the event of a possible anomaly, they could be inspected for conformity at HQ. It would be easy to find out if the part did not meet the drawing and, in such a case, a penalty would be levied. 'If there was a horrendously gross violation, then the team would have to be chucked out of the championship,' adds Bowlby. 'Not using published parts would be a black and white no go.'

The series' organiser would publish all changes that any

the rate of technology growth has become critical for competitiveness

combined price of the spare parts for a complete car cost no more than \$386,000. A cost cap would be in place but it would not have been portrayed as such. The true cost of a part might have meant that it could not be used within that ceiling. However, the manufacturer could still supply the part, but only if the price to the customer was lowered to meet the rules. Initially, this might not make commercial sense, but other returns on investment, such as marketing or technology advancement opportunities, offer reasons to take on this cost burden. In some ways, this aspect of Bowlby's scheme reflects the 2012

team may have made, meaning that such as Ganassi would know what Penske was doing and vice versa. This would avoid any acrimony and there would be complete transparency. 'The goal of this would be to leave no one behind and ensure that the best technical solutions would be largely adopted. However, there would be nothing stopping teams from doing some development that improves the breed.'

It might be said that the latter action would be counterproductive, in that it would ultimately benefit all teams, but Bowlby answers this by saying that, in this way, the team concerned could prove to sponsors that it not only wins races but also drives technology. The team could also make money manufacturing these parts for others on the grid. A suitable lead time would ensure that no team, including the originator, had the part in advance of its rivals, and slowly the car's spec would improve and quality would be assured. Put like that, it seems to be a win-win situation.

IndyCar regulation that says aero kits must be sold for \$70,000, a figure way below their actual development cost.

Bonded into each chassis there would be a RFID (Radio-Frequency

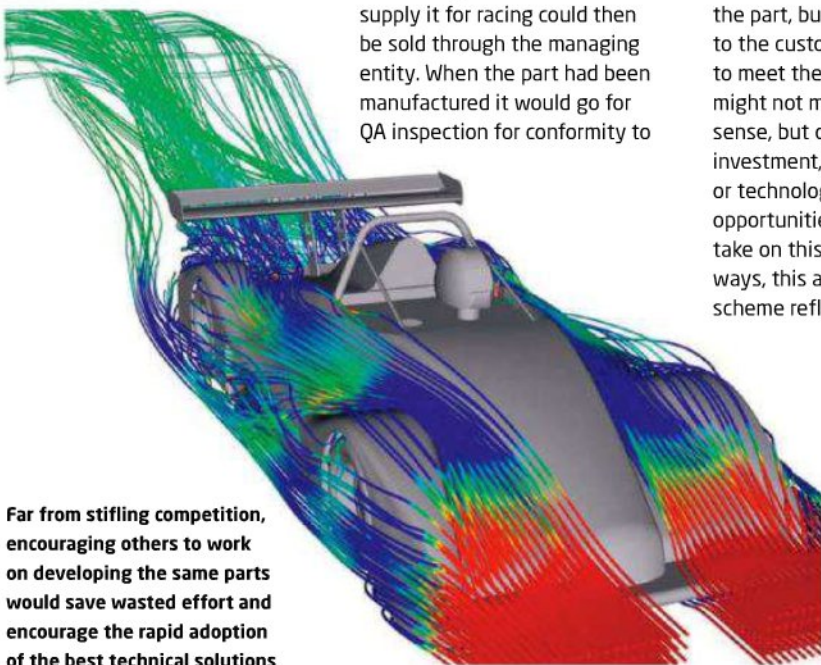

Far from stifling competition, encouraging others to work on developing the same parts would save wasted effort and encourage the rapid adoption of the best technical solutions



a new generation connecting rod

M2000 is a truly exciting & innovative advance in material specification, bridging the gap in cost and performance.

- reduced component mass
- exceptional core strength (2100MPa)
- increased durability
- maintains plastic elongation
- low notch sensitivity
- ideal for high stress applications
- high fatigue strength
- high tempering steel



Arrow Precision Engineering Ltd,
12 Barleyfield,
Hinckley Fields Industrial Estate,
Hinckley, Leicestershire.
LE10 1YE
United Kingdom

tel: +44 (0)1455 234200
fax: +44 (0)1455 233545
web: www.arrowprecision.com
email: enquiries@arrowprecision.com



Made in England



authorised Agents for ARP

at the heart
of the world's
most powerful
engines.

D.A.T.A.S. LTD.

Data Analysis Tools And Simulation

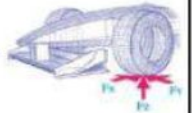

RaceSim version 2.7

- **Expert:** Steady state, transient, 4 post, optimisation, strategy, etc
- **Standard:** Low cost lap simulation
- **NasCar:** Stock cars with live axle
- **F3 Lite:** Incl. Dallara F3 car model
- **RaceAlyzer:** Race strategy tool - **NEW**
- **ManagePart:** Parts management tool - **NEW**



Consultancy

- Vehicle Dynamics
- Racetrack support
- Software Development



Multi Media

- Photo realistic virtual animations
- Technical Features for TV
- Animated virtual walk thro' grid



See D.A.T.A.S. at the Autosport Engineering show

D.A.T.A.S. LTD. THE OLD CHAPEL NORFOLK IP21 4XP

TEL: +44 (0)1603 506526 +44 (0)7802 770345

<http://www.datas-ltd.com> e-mail: info@datas-ltd.com

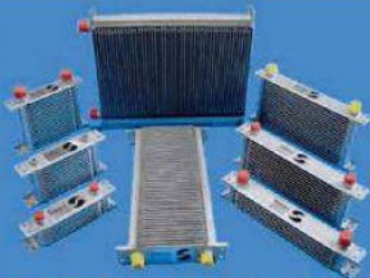

MOCAL High performance air to oil coolers



Oil cooler installation kits



Remote filter heads & take offs



Electric water pumps, release engine power



Dashboard gauges



Oilstats control oil temperature for more power & mpg



LAMINOVA oil to water coolers



Electric oil pumps for transmission cooling



Holley & Facet fuel pumps



Custom hoses for oil, fuel, brakes & coolant, Aeroquip, ProGold, Moquip & Speedflow



World biggest filler cap distributor



Early warning switches & bulbs

Manufacturers of **MOCAL** & Moquip oil cooling equipment. Distributors of automotive fluid control products.

Online shop @ www.thinkauto.com
Catalogue £2 refundable.

Think Automotive

www.thinkauto.com

292 Worton Road, Isleworth, Middlesex, TW7 6EL
Tel 0208 568 1172 Fax 0208 847 5338
Email info@thinkauto.com

The Competitive Edge!

REAL SQUARE

Wheel Alignment Systems for Motorsports



Real Square RS400PRO

Four Wheel, Chassis Mounted Dynamic Wheel Alignment Systems. Measure wheel movement in 5 different axes. Available for most types of Motorsport.



Injection Style Wheel Bearing Packers



Bump Steer Gauges



Wheel & Chassis Measurement Fixtures



Adjustable Wheel Bearing Pre-Load Spacers

- Chassis Pull Down Fixtures
- Digital Toe Gauges
- Wheel Base Gauges
- Slip Plates
- Scale Leveling
- Slip Plates
- Torque Absorbing Axles
- Seal Drivers
- * Low Drag Seals & Bearings



Scalloped Aluminum Suspension Tubes



Low Drag Hub Set-Up Service



Spindle Fixtures for Building & Testing

Download our latest Catalog @ DRPperformance.com

DRP
Performance Products

(1) 540-483-4442 888-399-6074

sales@drpperformance.com

Rocky Mount, Virginia, USA

"...let us run with endurance the race that is set before us..." Hebrews 12:1



Injection control

How McLaren won the bid to provide the electronics that will control the new fuel injection system in next year's NASCAR Sprint Cup

Names like Lehman Brothers, Fannie Mae, Freddie Mac and Northern Rock may seem at first glance to have very little to do with the NASCAR Sprint Cup technical regulations, but they were one of the main driving forces behind the biggest change in Stock Car racing since the arrival of the Car of Tomorrow.

In 2012, the much loved four-barrel carburettor will give way to fuel injection in NASCAR's top category.

'We did not introduce fuel injection for the reasons you may think,' explains Mike Fisher, NASCAR R and D's managing director. 'We did not feel that we needed more power - 850bhp is more than enough for great racing. We've had ongoing discussions with the manufacturers over the past several years regarding fuel injection and the timing is right for us to introduce it. We want to be responsible partners and we're confident this relationship will

BY SAM COLLINS

provide us with the opportunity to do just that.' A couple of years ago, NASCAR faced the very real possibility of big car makers pulling out of the series due to the problems with the economy, and that forced them to re-assess things. It was clear that other car makers did not want to invest in developing a carburetted V8

“ The air induction path is not changing so costs will be kept under control ”

engine. 'So there are really two main reasons that we chose to go this way: the first is that it is what our manufacturers wanted - both those in the series and new ones coming in - and we have to address that. Secondly, so far people like the EPA (Environmental Protection Agency) have left us alone, and

we want to keep it that way' Fisher adds.

There was no real secrecy surrounding NASCAR's desire to go to fuel injection, but few knew which way it would go, perhaps not even those within the organisation. But NASCAR R and D had decided on the layout: 'There will be one injector per cylinder, mounted in the manifold, and the injector position will be the same for all manufacturers.

The air induction path is not changing, so intake development costs are kept under control.

'From an optimisation point of view, it is not the best position for the injector, but we don't want any more power, though there may be a small increase.'

With that sorted, an extensive request-for-quote process was

launched by Fisher's team at NASCAR R and D in Concord, NC to investigate potential partners.

'We looked around the world and issued a specification of the system that we wanted. It was very open, there were some smaller companies in the US that we knew we would look at but we did not want to limit ourselves.'

TAKEN BY SURPRISE

The winning bidder took many in the industry by surprise - McLaren Electronic Systems (MES), the supplier of Formula 1 and IndyCar ECUs and part of the McLaren Group, which also contains the Formula 1 team and the Sportscar manufacturer. It was hailed by some as McLaren's arrival into NASCAR, but really it was nothing of the sort, as Peter van Manen, MES managing director, explains: 'We started working with the NASCAR teams in 2005, dealing with alternators and some specific sensors, and through that we got to know a number of the teams. Then, in 2007, we opened a facility in

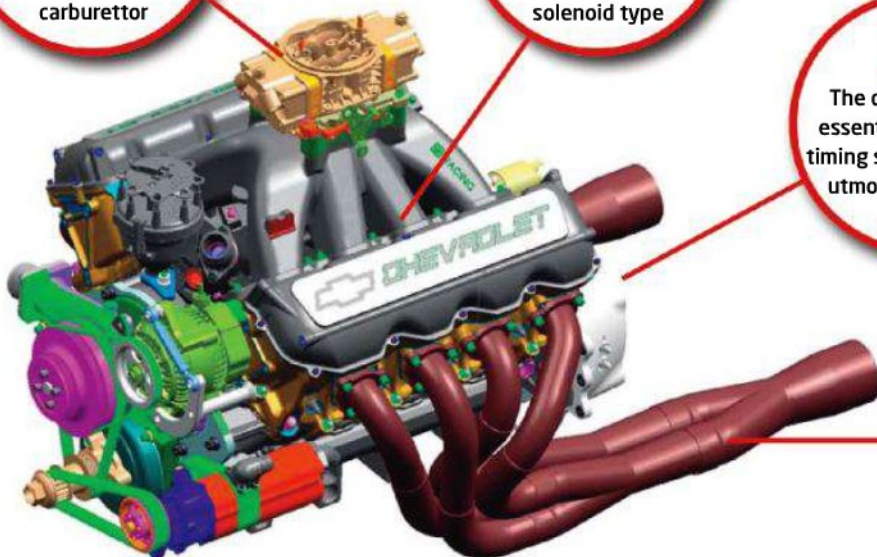



Lap trigger receiver
Detects when the car passes the lap trigger



Three-axis accelerometer
Used for the safety strategies in the TAG-400N



Relay box
A component that will probably be open to any approved supplier

Mooresville, NC. When it became clear that NASCAR was seriously looking at fuel injection, we made it clear we were interested, so when it went out to tender we submitted a bid.

The final package will be driven by a TAG-400N ECU supplied by MES, an evolution of an already well-proven system. 'Because NASCAR is such a big and high-profile series, we were keen to introduce an ECU that

had some miles on it. So, in terms of the basic architecture, the NASCAR ECU is a clear evolution of the unit we supply currently to IndyCar,' he reveals. 'It is not identical, but it uses the same processors and basic interfaces.'

MES ECUs have never stopped a car in either IndyCar or Formula 1 and the IndyCar version was subjected to the ultimate crash test during the 2010 Indy 500, when Mike Conway's Dreyer and

Reinbold Dallara was destroyed after it was launched into the catch fencing at over 200mph. The ECU was torn from the car during the incident (see picture overleaf) yet, when it was returned to MES, it still functioned, so should certainly be able to withstand the bumping and barging that is part of the NASCAR Sprint Cup.

FORMULA 1 SECURITY

However, it was not only the hardware that had to be robust, as van Manen explains: 'They [NASCAR] came to us with a clear technical requirement, but there was a sporting requirement, too. It was important that you didn't have a situation where people were taking advantage of the system. It needed to be completely secure and free of

any ability for tampering. So the software is new, and the system has all of the security we have established in Formula 1. We lock off the units and prevent the units running with any code it shouldn't. You just cannot run illegal code in these units.

'Having said that, NASCAR will have methods of checking that the software version being used is approved. So the first line of defence is that it is not possible to run illegal code, the second line of defence is that it can be checked. It is a completely bulletproof set up.'

The teams themselves will not be totally locked out of the software, as scope for fuel delivery tuning adjustments has been engineered in, as Fisher reveals: 'It is similar to what they can do now with the carburettors.



McLaren is understandably proud of how tough and reliable its ECUs are, having withstood Mike Conway's horrific 200mph crash during last year's Indy 500. That's the detached ECU circled, which still functioned afterwards!

Ignition mapping is allowed, but only with a 2D map, and you can't change the size of the map. So, for example, we may say it's 14 x 14 and everyone will have to work within that.'

SUPPLIER CHAIN

Arguably, the software is capable of removing the need for the air restrictors at super speedways too, but for now NASCAR is keeping the plate. 'The advantage of the plate is that if you limit the air then there is no temptation to do much to the fuel side, but when you limit the fuel it gets tempting to do things on that side,' explains Fisher.

In the tradition of NASCAR, however, the rest of the fuel system will not be a single spec, but built to a template. 'The

components in the fuel system will be open for selection - Holley with the throttle body, and the lambda sensors are likely to be from Bosch, as they are really the only people who make ones to our requirements. Outside of

probably mandate a couple of families of connector.'

'The mandated parts are kept to a minimum,' adds van Manen. 'The actuators and sensors attached to the ECU need to be compatible with the

It's going to be a free market... a balance between performance, reliability and cost

that, many of the sensors and parts will be open to teams for selection and the wiring is all free, though made to a schematic. Having sensors team sourced may mean we have to have free connectors too, so we will

ECU, of course, but in terms of making them compatible, most of them are fairly straightforward 0-5v outputs, so they go direct into the ECU. The ones like lambda and speed sensors have separate inputs. It's going to

be a free market and it will be determined by a balance between performance, reliability and cost.'

The injector supplier has not been announced yet, as NASCAR investigates the best potential suppliers, though it is known that it will be a solenoid injector. However, the positioning of the injectors being mandated will give the engine builders a new challenge, as van Manen speculates: 'I think when you look at the geometry, it will focus more attention on the bottom end of the manifold. I suspect there is not quite as much optimisation to be done as with the carburettor engine, where you have to look at the shape and direction of the jets, how the upper part of the manifold works and how you can optimise your airflows to get the balance between the cylinders right. It is quite a complex little problem, which is now being replaced by a different complex little problem. You still have to manage the airflows to the different cylinders, though, so there will be the manifold optimisation for that, but it's the same as any racing category, whether it is airbox or manifold - balancing airflow is just what you have to do.'

The challenge facing the NASCAR engine builders then is something pretty much all Stock Car racers will have to face in the coming years, and MES has indicated that it will at some point in future offer its ECUs to a wider oval racing market, too. So even a Late Model team may one day be able to have some F1 know how on its engines. **R**

THE MCLAREN / FREESCALE CONNECTION

McLaren made its bid for the NASCAR contract in collaboration with long-time associates, Freescale Semiconductor, which clearly made it an attractive proposition to Stock Car's governing body.

'In the late 1990s, we decided that for our control systems we would switch from a traditional way of creating our software to a model-based system,' explains McLaren Electronics' Peter van Manen. 'That way you create your

applications as control block models, then auto generate the software in the unit, and one of the things to enable that was to use the new generation of 32-bit processors coming into the market at that time. For that, we selected the Motorola power PC, which became Freescale after a private purchase of the Motorola semi-conductor business. From the beginning of the 2000 season, our controllers were based around the Freescale semi-conductors, so we have

been with them for a decade.

'When the NASCAR ECU tender came up we talked with our colleagues at Freescale about submitting a bid. Given their large reach in automotive electronics and the fact that they are the biggest producer of micro controllers for the automotive industry and that it is such a central part of the control unit, it made sense to extend our existing technical relationship into NASCAR. So we approached NASCAR

together, with an offer based on the technology pedigree that McLaren Electronic Systems has, but with the added comfort of commitment from the supplier of semi-conductors that sit at the heart of it. So you have both a motorsport electronics producer and an automotive semi-conductor supplier - two companies with a history of delivering high-quality products working together to create the NASCAR system.



bf1wiring harness systems



37 strong team serving F1™, IRL, MOTOGP, NASCAR and Aerospace

Full design, prototyping and manufacturing services using the latest design tools, manufacturing and process technologies.

Designed to your exacting requirements, taking into account size, fitment, environment and cost.

In house design and integration of composite components, such as enclosures, brackets and channels as part of the wiring assembly.

All composites work undertaken is designed and manufactured using the latest CAD (Catia v5, UG) and then processed in our clean room and large high temperature autoclave.

Contact: Anthony Moss - Harness Production Manager
Tel: +44(0)1379646202 -
email: anthony.moss@bf1systems.com



FAST

COMPREHENSIVE

CONVENIENT

bf1 connect

bf1connect offers Motor sport engineers the complete range of electrical interconnect solutions and wiring harness components for race and rally applications.

As an official and preferred status distributor for the Souriau autosport range, bf1connect holds significant stocks of wiring harness components to ensure that parts are dispatched quickly and efficiently. Everything from boots, glue, wire and BSTA / BTA connectors

bf1connect is the largest distributor of Souriau Bsta motor sport connectors & specialist supplier of wiring components and materials in the U.K

Contact: +44(0)845 094 1660 - sales@bf1connect.com

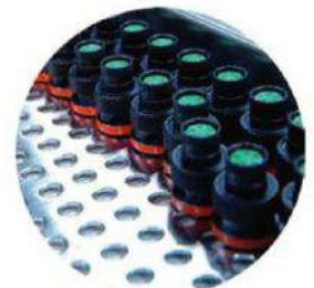

WE MAKE - YOU RACE

WINDFORM ADDITIVE MFG:

CAR AERODYNAMIC FEATURES
CAR BRAKE DUCTS
WIND TUNNEL PARTS
MOCKUP PARTS

WINDFORM ADDITIVE MFG:

ELECTRIC COVERS AND SPECIAL PIPES
INTAKE MANIFOLDS

MECHANICS:

SPECIAL SPLINED EDM PARTS
GEARBOX
ENGINE PARTS
COMPLEX 5X CNC MACHINED PARTS

MECHANICS:

UPRIGHTS/SPINDLES
ROCKER ARMS
SUSPENSIONS END FITTINGS

OTHER WINDFORM ADDITIVE MFG:

MOULD INSERTS
MASTER MODELS
SPECIAL JIGS

AT 300 KM/H QUALITY ISN'T OPTIONAL IT'S YOUR LIFE



www.crp.eu

www.crp-usa.net

info@crp.eu

info@crp-usa.net

HS CNC MACHINING . DIRECT DIGITAL MANUFACTURING . RAPID CASTING . ENGINEERING & REVERSE ENGINEERING
C.R.P. Group · Via Cesare Della Chiesa 21 · 41126 MODENA · ITALY · Phone +39 059 821135 · Fax +39 059 822071

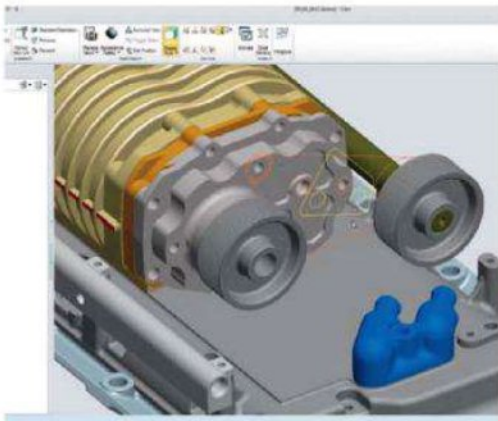
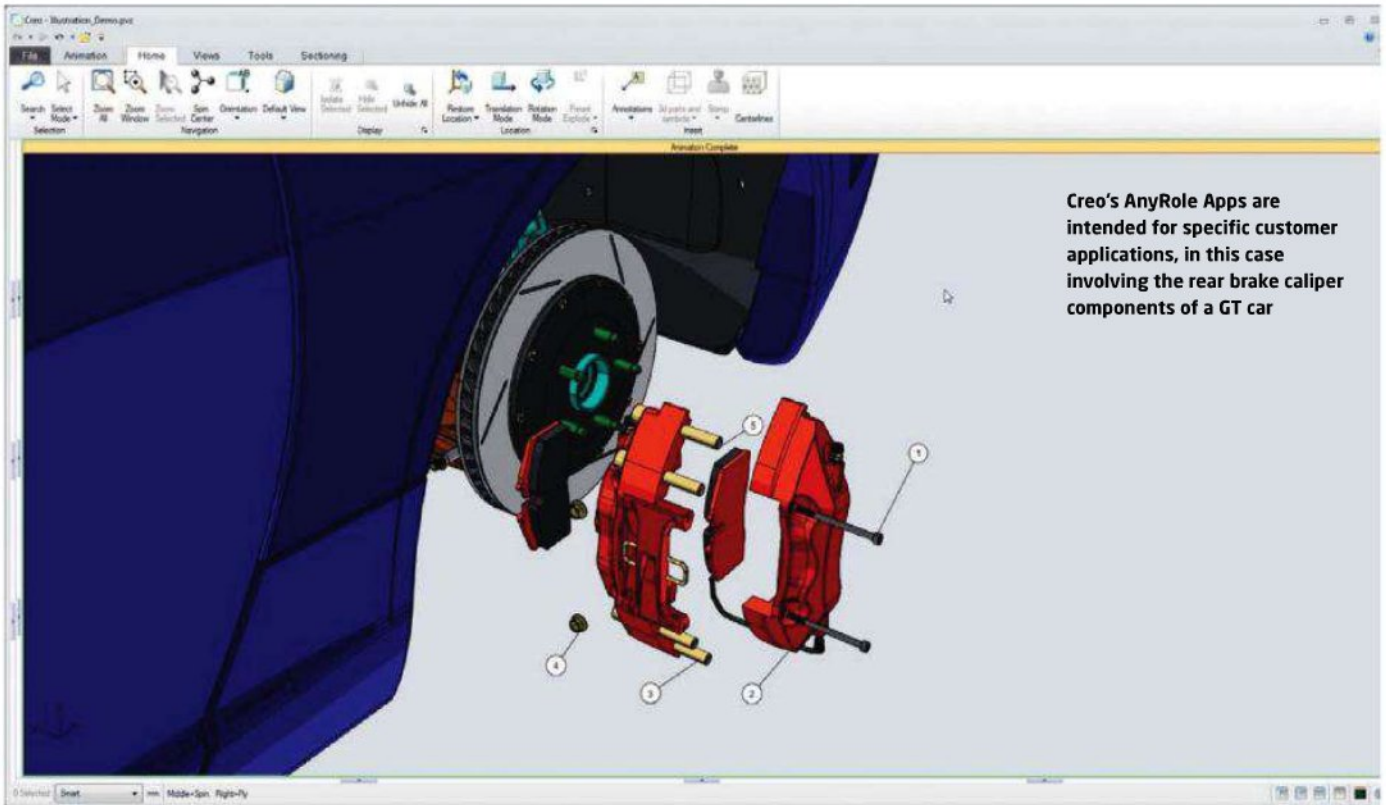

A new dawn for CAD?

With the launch of Creo, PTC aims to address what it sees as the major issues preventing 3D modelling moving to the next level

Any motorsport engineer or designer worth his or her salt is likely to be familiar with PTC's Pro/ENGINEER and CoCreate software, for parametric and direct modelling respectively. Launched by the Massachusetts-based company in 1987, two years after it was founded by Samuel Geisberg, Pro/ENGINEER parametric MCAD quickly established PTC as a pioneer and major player in the world of 3D product design.

In the course of the intervening 20 years, however, the CAD industry has matured and, some might even say, stagnated. This does not mean

BY GRAHAM JONES

that all the issues in the world of 3D modelling have been resolved - far from it. In fact, in failing to deal with these shortcomings, one senior PTC executive likened the industry to 'walking around elephants in the living room'.

For that reason, PTC instigated 'Project Lightning', and quickly identified what it considered to be the four major issues relating to existing software:

- **Ease of use**
- **Lack of compatibility with other software (interoperability)**
- **Technology lock-in by vendors**

- **Lack of product configuration modelling capability (realistic assembly management)**

The goal Project Lightning therefore set itself was to unlock the potential of modelling software by addressing these shortcomings.

The result is Creo - from the Latin root 'to create' - and, according to the company's senior management, 'represents PTC's vision for the next 20 years of mechanical design'. In fact, it is a new family of design software created from elements of the firm's Pro/ENGINEER, CoCreate and ProductView software and claims to provide four breakthrough technologies:

AnyRole apps; AnyMode modelling; AnyData adoption and AnyBOM assembly.

ANYROLE APPS

As the name suggests, these are purpose-built apps for specific customer applications, variously described as 'the right app for the right person at the right time' or 'the Goldilocks of apps - to make it just right'. The overriding aim is to make such apps more accessible to end users.

ANYMODE MODELLING

Based on the need for data to move easily between apps, the goal is to avoid 'dead-ends' when moving from 2D to 3D renderings. In the case of Creo, PTC claims an

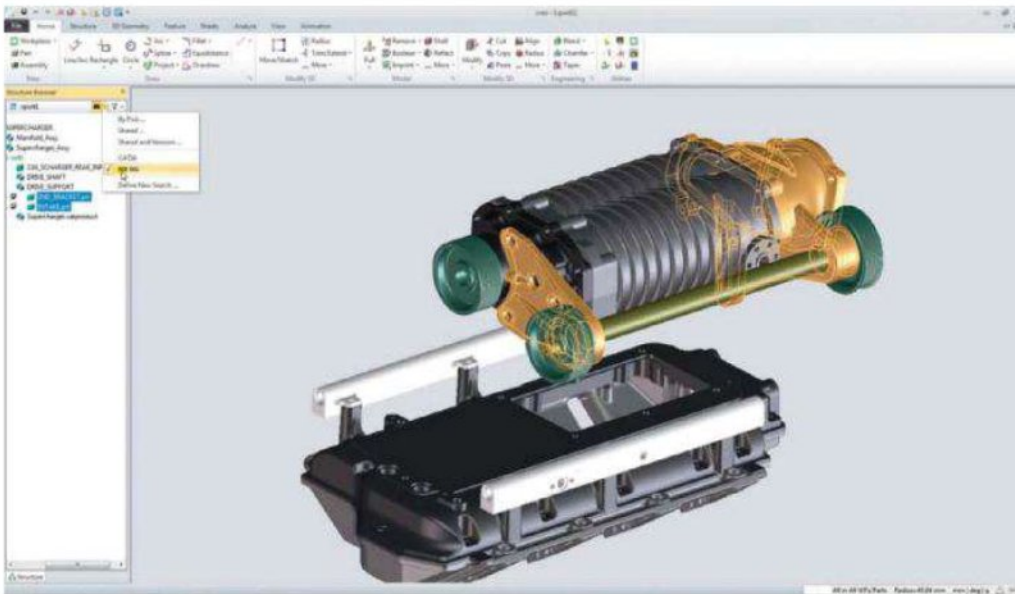

AnyData Adoption allows importation of data from other CAD tools into Creo, here to check possible clearance issues

'unprecedented' level of fluency when moving from one to the other. Put another way, direct modelling changes are made easily and then translate into a role-specific, common data model.

ANYDATA ADOPTION

This facilitates the importation of data from other CAD tools. As PTC management points out, it's a multi-CAD world, and the aim of this feature is to enable data to flow into Creo, regardless of the software system on which it was created. In this way, it makes

interoperability possible between different CAD sources with their origins becoming irrelevant.

ANYBOM ASSEMBLY

This is an app for the management of complex variations on an original

reconfiguration aspect based on a Windchill (PLM) kernel, although PTC points out that it's not mandatory to use Windchill with Creo. AnyBOM assembly permits a level of interoperability between PLM and CAD.

Creo represents PTC's vision for the next 20 years of mechanical design

design. It permits the creation of multiple different options with the

Initially, all Creo apps will run on the same core platforms

- Microsoft Windows 7 and XP - although selected apps may run on additional platforms in later releases.

Speaking of releases, a Creo 1.0 version is being rolled out to selected PTC end users this summer with a 2.0 version, incorporating customer feedback, scheduled for the autumn, PTC admitting that it is on a learning curve with Creo. Also clear is that in choosing to tackle what it sees as 'the biggest problems in the CAD industry' PTC has set itself a daunting marketing and communications task. As marketing director, Rob Gremley, says succinctly, 'PTC now equates to Creo,' the result being that the whole PTC product offering has been realigned. The new family of products consists of Creo Elements/Pro (formerly Pro/ENGINEER), Creo Elements/Direct (formerly CoCreate) and Creo Elements/View (formerly ProductView).

PTC has clearly not chosen an easy path in making these sweeping changes, but it's clear the company's senior management want to reflect the fact that the launch of Creo marks what they believe to be 'a milestone day in the history of CAD.'

For further information visit www.creo.ptc.com and www.ptc.com/products/creo

ASTON MARTIN SEE SIGNIFICANT BENEFITS

George Howard-Chappell and the engineering team at Aston Martin Racing used a cutting edge new software package in the design of the new AMR-ONE Le Mans car. The team selected and implemented PTC's Creo, and also employed the same firm's Windchill PLM software.

Aston Martin is the only manufacturer that produces a car to compete in every category of the FIA GT class structure. It has moved away from its previous third-party chassis strategy to develop its next generation LMP1, the AMR-ONE, from scratch. This new racing vehicle is now being designed and engineered from the ground up using Creo Elements/Pro and Windchill to manage the



development process. In addition to the designers, the purchasing department uses Windchill for its request for quotation process, enabling close collaboration with suppliers.

'The PTC solutions have far greater capabilities than our previous toolset,' said Ian Ludgate, chief designer at Aston Martin Racing. 'Although we are still very early in our

learning of the system, we've already seen significant benefits in simple things like mechanism design, which is built into the Creo Elements/Pro toolset and subsequently distributed by Windchill.'

'We implemented Creo Elements/Pro to optimise our design process and Windchill to streamline and manage our processes,' said Steve Baker, PLM specialist at Aston Martin Racing. 'To achieve ultimate efficiency, we needed a single, comprehensive PLM system that supports the entire design, from early-stage product development to manufacturing. With Windchill, our data will be complete and in one location.'



TEXYS designs, manufactures and distributes a range of sensors for racing, automotive and industrial applications:

- Infrared temperature sensors (for tyre, brake disc, clutches...)
- Thermocouple amplifiers (patented)
- Accelerometers and gyroscopes
- Strain gauge bonding + amplifiers (push rods, wishbones...)
- Pitot sensors and differential pressure sensors
- Gear shift devices (flexion and tension/compression model)

TEXYS is renowned for **product reliability and accuracy** and is consequently called upon to work with major professional teams and manufacturers. The company has been working with motor sports professionals **since 1999** and is involved in all the main international motor racing championships: Formula1, MotoGP, WRC, Nascar, IRL, Le Mans Series...

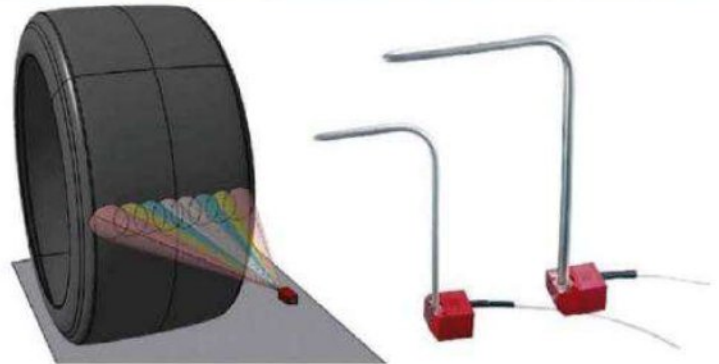

Our multi-expertise set up enables us to work on the customised development of specific analogue and digital sensors. Our products are distributed through a network of agents and through our subsidiary in the United States.

www.texense.com

Tel : +33 (0) 386 21 27 18



MAKE THE DIFFERENCE



Make the difference in your Porsche engine project with superior quality of Saenz connecting rods. Tailor made in steel or Titanium, Saenz offers what you are looking for. Not from the shelf, just what you want.



Jacquemin Tuning - 233 avenue de la république - 59110 La Madeleine - France - +33 (3) 20746480 - www.jacquemintuning.com - info@jacquemintuning.com

Direct drive



Two rallies into the 2011 season, the new era World Rally Cars are already providing an exciting spectacle on the stages. Built to fresh, more restrictive rules, they respect driver ability and provide tough, competitive motorsport. Here's how Ford approached the technological challenge

While new tyre suppliers and a raft of limitations on materials and components have all had an impact, the biggest change of all for the new WRCs has been to the engines. To bring rally car technology in line with today's road cars, the FIA has mandated direct fuel injection. To reduce costs, it has also prohibited the use of titanium, magnesium, ceramics and composites, except when used in the production car the WRC is based upon. Further restrictions on sensors and data transfer, ECUs, revs and differentials all mean the cars are significantly simpler than last year's cars, but all this has presented challenges for the engineers tasked with building them.

Active limited slip differentials and centre diffs on four-wheel drive cars are now banned and driveshaft assemblies must be interchangeable side to side. Only mechanical gear change mechanisms are allowed and chassis control aids, such as ABS and ASR, are prohibited. The ban on a central differential carries over from the 2010 Super 2000 rules and introduces transmission wind-up - and requires an adapted driving style. However, a less preferable dynamic effect is when negotiating hairpin bends, so the FIA has allowed mechanisms to temporarily disconnect drive to the rear axle. Two systems are homologated, made by Xtrac and Sadev, and both are positioned at the rear differential, achieving disengagement through a clutch system activated when the handbrake lever is pulled. The Xtrac system uses a supplementary master cylinder

BY MARTIN SHARP

on the handbrake, while Sadev has incorporated a handbrake-activated hydraulic pump. Each specialist gearbox has six forward speeds, which has proven in the past with 2.0-litre turbo WRCs to be preferable to five ratios at low-power, high-altitudes stages, such as Mexico and Argentina.

The new cars themselves are based on the Super 2000 concept, which calls for minimum four-metre length B segment four seaters. The maximum allowed body width goes up 20mm from the 1800mm of last year's WRCs and minimum weight drops 30kg from the previous 1230kg, with minimum weights for gearbox, diffs and engines.

The FIA has mandated direct fuel injection

Carbon dioxide output taxation, ever-reducing speed limits and emphasis on reduced fuel consumption have resulted in more road cars being produced with small capacity, direct fuel injection engines and, at 1.6-litre capacity (down from 2.0-litres previously), the new turbocharged WRC engines follow this trend. An FIA-specified Garrett turbocharger is mandatory, yet designers can mix parts and assemblies from a standard engine with pure competition parts or have the option to develop a unique competition engine from the ground up. While material and dimensions are strictly controlled, the so-called 'Appendix Engine' concept is essentially similar to the American 'stock block' engine

blueprint. These 280 / 290bhp engines are now expected to last a minimum 6000km between rebuilds, rather than the costly 1000km rebuilds of yore.

Either dry or wet sumps are now allowed and mandatory identical dimensions and rotating and reciprocating components ensure performance parity between engine types. Power outputs are regulated using 3mm long, 33mm diameter intake air restrictors placed 50mm upstream of the compressor blade edges, between the butterfly and inlet manifold. In addition, the use of a system that limits turbocharger boost pressure to 2.5bar is compulsory, and is monitored throughout events by an FIA black box designed by ex-Citroën Racing electronics expert, Sylvain

Riviere. Essentially, Riviere's system comprises a specific sized tube between the butterfly and intake manifold, which carries three sensors - two for the FIA and one for the competitor. These sensors feed a small FIA computer 'box' for scrutineers to read. An illuminated green light shows everything is within the rules, an orange light shows there is a problem, while a red light indicates an over boost or over speed. When problems are indicated, a small plug-in system determines its nature.

For further cost reduction, the FIA is aiming for two engines per car per year and one gearbox for three rallies next year. However, because the current engine technology is new, until the end of April engine specification





The Focus RS WRC uses MacPherson strut suspension all round with machined aluminium uprights, fabricated steel links and Reiger adjustable dampers

TECH SPEC

Engine: Ford EcoBoost 1.6-litre direct injection developed by Ford, M-Sport and Pipo Moteurs. Four cylinders, 16-valves
Bore: 83mm, stroke: 73.9mm
Cosworth electronic engine management Garrett turbocharger (with FIA mandated 33mm restrictor), air intercooler, catalytic converter
Power: 300bhp at 6000rpm
Torque: 450Nm at 4000rpm

Transmission: permanent four-wheel drive; mechanical front and rear differential with a clutch disconnect; M-Sport / Xtrac six-speed sequential gearbox with mechanical shift; M-Sport / AP Racing twin-disc clutch

Suspension: MacPherson struts front and rear with adjustable Reiger dampers; adjustable fabricated steel links; front and rear anti-roll bars; machined aluminium uprights

Brakes: 300mm Brembo ventilated discs (gravel); 355mm Brembo ventilated discs (asphalt); Brembo four-piston monobloc calipers

Steering: Power-assisted, high ratio (12:1) rack and pinion

Wheels and tyres: 7 x 15in aluminium wheels (gravel / snow); 8 x 18in (asphalt); Michelin tyres

Bodyshell: unitary construction; composite side panels; welded T45 steel rollcage; aerodynamic rear wing; unique front bumper

Electronics: full Cosworth chassis and engine data acquisition for on-event diagnostics and performance development

Fuel tank: FIA FT3.5 tank, 80-litre capacity, centrally located

Dimensions:
 Length: 3963mm
 Width: 1820mm
 Wheelbase: 2480mm
 Weight: 1200kg

changes are free. If, after that, reliability problems remain, teams can use five 'jokers' this year - then a further five for the rest of the homologated life of the car. FIA technical boss, Jacques Berger: 'They [the manufacturers] will try to find reliability. They will not try to make the engine more powerful because they know that in May [they have two engines only] so they will make all the effort to make reliability.'

Ford / M-Sport's Fiesta RS WRC and Citroën Racing's DS3 WRC are currently contesting this year's championship, with the Prodrive built and run MINI John Cooper Works WRC joining the series at May's Rally of Italy in Sardinia, and Volkswagen expected to announce its WRC participation in 2012. There are also rumours that Saab may enter the competition and a number of other non-European manufacturers have also made tentative contact with the FIA regarding joining the series, but none has yet confirmed.

FORD FIESTA RS WRC

Designed, built and run by Malcolm Wilson's M-Sport operation near Cockermouth, Cumbria, UK, the new Fiesta WRC had somewhat of a head start in the 2011 championship,



having been rallied as a 2.0-litre, normally aspirated Super 2000 car in 2010, which perhaps helped short cut some of the tasks required to optimise the new 1.6-litre WRC version.

Built to the regulations, but using conventional rally car practice, the MacPherson strut suspension all round uses adjustable fabricated steel links and machined aluminium uprights with front and rear anti-roll bars and external reservoir Reiger dampers, adjustable for bump and rebound.

A fundamental difference between the Ford and its French rival, however, is that Ford has opted for a power unit based on a production cylinder block, but fitted with a competition-designed cylinder head. The block is based on the Ford '14' casting, used in the company's current road going 'EcoBoost' engines. Similarly, the WRC cylinder head

is based on the current I4 head, but modified for direct injection.

Late changes in the regulations meant the lead time for the cars' build was very short indeed, but team boss Malcolm Wilson was unfazed by this: 'We've never had such an easy time since we've been running the Ford programme, though in many ways that puts us under a bit more pressure - 'Have we missed anything? Is there anything else we could have improved?' Because we didn't have to homologate until the 11th hour, we've been optimising what we could from a testing point of view. We've done 11,000km now [pre-Sweden], which is unheard of before a car does a rally.'

Wilson also points out that the reduced scope for development implied by some of the new technical rules puts more emphasis on the drivers



The new B-segment cars are generally narrower in the cockpit than the outgoing C-segment cars



The Fiesta's powerplant is based on Ford's production I4 block and head, as used for the EcoBoost engines in the manufacturer's current road car range



Being able to accurately control the direct injection system has been the biggest challenge, says M-Sport technical director, Christian Loriaux

doing their jobs right.

The mandatory direct fuel injection is the essential innovation in the new rules. Such systems run fuel pressures of around 200bar and M-Sport's technical director, Christian Loriaux, has arranged for this pressure to be managed only at the Fiesta's engine. The injection pump is driven off a camshaft, feeding pressurised fuel through a short pipe to the injector rail.

But where with many modern road cars direct injection is optimised at part throttle, with a competition engine you want peak performance to be at wide-open throttle, as that's where you want to be as much as possible. Loriaux: 'You have to inject the fuel directly into the combustion chamber, so you have to have a pressure which is higher than the compression pressure, otherwise you wouldn't be able to inject. This means you have control all the time of the fuel pressure and you are injecting fuel at between 40 and 200bar. Obviously, when you are on part throttle and don't have so much pressure in the engine, there is no point injecting at 200bar because you're using unnecessary power to compress the fuel to that pressure. So, it's a very complicated, closed-loop control all the time of the fuel

pressure, to vary it to exactly what you need.

'Then there's the shape of the combustion chambers and ports and the way you do the mixture - the tumble, the swirl and all these things. And the spray pattern is very important as well, because you need it to mix very quickly. You don't want the fuel to hit the cylinder walls.'

The team admits it is still learning, and has undertaken much modelling work with Ford to optimise the spray pattern. Loriaux explained that combining expertise means arriving at 95 per cent of the ideal reasonably

↳ a very complicated, closed-loop control all the time of the fuel pressure ↳

easily and swiftly, but that the final five per cent is very time consuming, and specialised.

M-Sport did debate including an accumulator into the high-pressure side of the fuel system, but instead opted to keep the pipe from pump to rail short. Loriaux: 'The pipe is very rigid and, because the fuel is non-

compressible, and you've got the piston pump, you can in theory go from 0-1000bar, or infinite pressure with just one stroke.

'The pulsing of the pressure can be difficult, though. With the pump working, we want to go from 40-200bar in a few milliseconds, and controlling that precisely is not easy. But we've got very good dynamometers and, since probably February last year, we were running bog standard 1.6-litre EcoBoost engines with direct injection, and with all the electronics, sensors and controls to learn and tune that side of the software. We

spikes are inevitable: 'The main thing is for them [the FIA] to find out how many milliseconds of spike can be acceptable. If you don't go above 2.5bar, with the size of the turbo as it is and with the power curve, effectively at 8500rpm we're losing power, so you change gear before that. And you don't go to 2.5bar boost because we're not in the efficiency part of the turbo.'

GEAR RATIOS

The Xtrac gearbox for the Super 2000 Fiesta was designed to be sufficiently beefy to take the torque from a 1.6-litre turbo from the outset, so it's no surprise its architecture and bearings in the WRC are the same, yet the new engine's power curve demands different gear ratios. These have to be defined for the full year, so teams must be certain they have the best they can get from the beginning. Loriaux: 'In the old car, with a 2.0-litre turbo and a restrictor, we had the same power over like 3000rpm, so the range was absolutely massive. That's why we argued you could do a six-speed gearbox or a five, four or even three speed and be as quick as a six speed.

Marcus [Grönholm] has actually proven that in the Peugeot, winning some of the fastest stage times with three speeds because the overlap is so big. This engine is not as peaky as the S2000, but it's much more peaky than the old [2.0-litre turbo] engine. Our range now of the same horsepower is going to be like 1500 / 2000rpm above 3000 / 3500rpm, and between two or three gears you've got between 1000rpm and 1500rpm drop. Our engine characteristics were developing and changing as we were making the car so, effectively, when we did the first ratios we had in mind that the car wouldn't run much over 6500rpm with that restrictor. Then when we started up the initial engine for the first time we found that

the engine power was going to about 7000rpm. So the first set of ratios I think we scrapped from the start, because you need eight or nine weeks to do your ratios. You need to guess your theoretical power curve - that was a big and important job.'

The M-Sport technical boss wouldn't be drawn on exact power and torque figures for the new unit, but did make the point that the actual torque figure is not relevant: 'On the 2.0-litre WRC you could argue that we had 800Nm on the dyno, but you were never getting that because we never had the grip to get that. So the figures you see on the dyno are really not real life.'

As for the lack of a centre differential, when M-Sport configured the Super 2000

car last year, it was decided to save weight and complexity by running without one. Then the regulation changed and went that way, which helped the team greatly with the development of the WRC version. In terms of the rear drive disengagement mechanism, Loriaux makes the point that deploying the mechanism loses propulsion at the rear wheels, which is fine for hairpin entry set up, but not elsewhere - although some intriguing developments with regard to this system seem to have come to light after the first two rallies this year...

So compared with last year's WRCs, Loriaux sees the big difference in the fuel being mixed directly inside combustion chambers at higher pressures, and

predicts a future in competition for this technology: '30 years ago, everybody was happy with Weber 40DCOs, or 45s, and when the port injection engine came in a lot of people thought, 'Why do we need all that regulation?' It doesn't really give you more power and doesn't do it much better, yet nowadays nobody would want to go back to the Webers. We found that the port injection was much better to manage and *did* reduce consumption and increase reliability. I think it will be the same with direct injection - it's the beginning of the story and hopefully we will develop the benefits.'

Racecar Engineering will be there to see how the new technology is developed. 

SPARE TYRES

↘ The logical link to competitiveness and the only connection to the ground surface, which in the World Rally Championship means a gamut of surfaces and conditions, WRC tyres are critical. From 2008 to 2010, Pirelli provided all WRC rubber, but this year the FIA opened the market to different tyre manufacturers' tenders. Michelin, previously a WRC tyre provider under its BF Goodrich banner, had its bid accepted. Then, under ex-Pirelli engineer Dick Cormack, DMACK also became an official supplier of its Chinese-made covers to the 2011 WRC. Michelin currently equips the top teams, while DMACK centres on PWRC and

S2000 teams.

The Chinese tyres are made by Yongtai Group, which manufactures 22,000 tyres per day and specialises in high-performance products. They are aimed at privateers and

reinforced sidewalls for puncture resistance and run-flat shoulders so the tyre can be driven on if it does puncture. And there's a significant difference in cost - a Michelin gravel tyre costs 300 euros, a DMACK 170 euros.

this year the FIA opened the market to different tyre manufacturers

less-experienced competitors who need to finish events, hence compounds and constructions - all developed specifically by DMACK - are aimed at durability, puncture resistance and run-flat capability, having Kevlar-

Although Michelin's puncture tally so far has been substantial, at least compared with that of Pirelli in the previous three years (just 43 out of 27,995 tyres supplied), Michelin's competition director, Nick Shorrock, says he

is satisfied, pointing out that its tyres are designed to be competitive in a relatively open market, and that the new, slightly lighter, slightly less powerful cars demand a 'different' ie more forceful driving style. And while previous supplier, Pirelli, opted for 'bomb-proof' sidewalls, in the search for an apt blend of puncture resistance and performance, Michelin has taken the potentially better performing, more supple construction option, which is widely regarded as a reason for the high puncture count for the French covers in this early part of the season.

World Rally Champion and Mexico Rally winner, Sebastian Loeb, has gone on record saying that the Michelins' performance is better than last year's control Pirellis, yet he doesn't like the risk of punctures, saying he was lucky to get just one puncture in Mexico close to a stage end. It's a sentiment echoed by Ford M-Sport's Malcolm Wilson, after the team's Jari-Matti Latvala, together with Norwegian coming-man Mads Ostberg, were ruled out of contention through Michelin punctures. Unsurprising then that Wilson has already investigated DMACK tyres, though Citroën Racing boss, Olivier Quesnel, has so far eschewed the option.

On Rally Sweden the Production World Rally Championship (PWRC) winner was fitted with DMACK tyres



WWW.REIGERSUSPENSION.COM



The best suspension for:

- Rally
- Rally Raid
- Rallycross
- Autocross
- Motocross
- Sidecar cross
- Quads

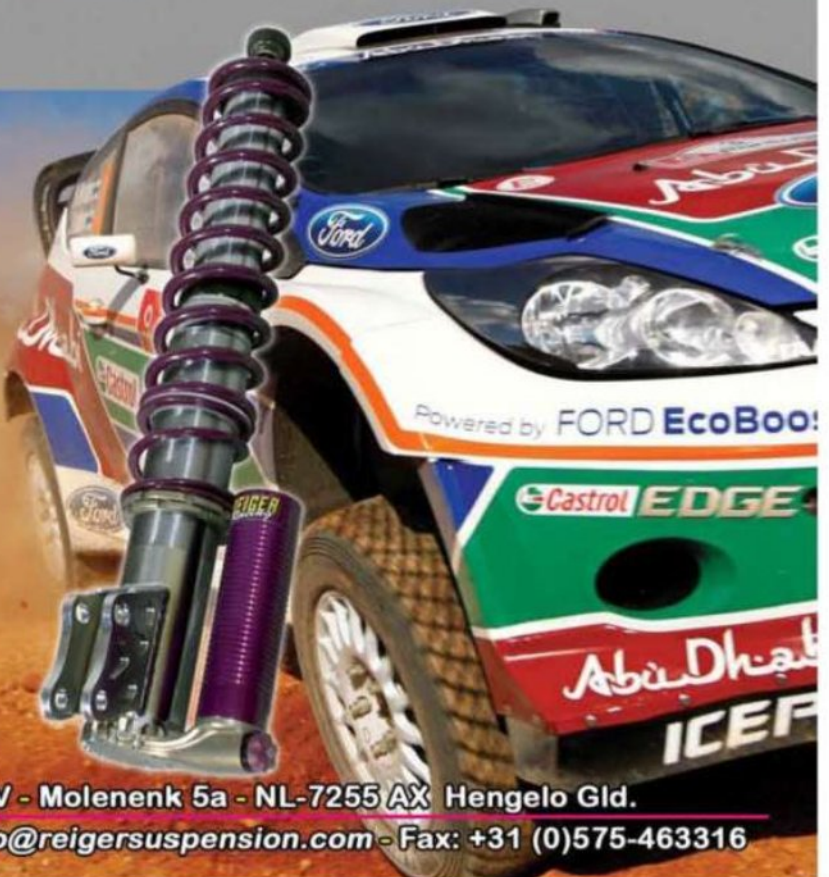

Reiger Suspension BV - Molenenk 5a - NL-7255 AX Hengelo Gld.

Tel.: +31 (0)575-462077 - info@reigersuspension.com - Fax: +31 (0)575-463316

Top Qualifier

Around the world or around the track, you won't find a higher quality line of bearings and rod ends with Aurora's proven 35 year track record.



Aurora Bearing Company
901 Aucutt Road
Montgomery IL. 60538



Complete library of cad drawings and 3D models available at:
www.aurorabearing.com

Ph: 630-859-2030

OvaX

STEELS FOR THE RACING INDUSTRY

- OvaX 200**
Case hardening steel
- OvaX 300**
Quench and tempering steel
- OvaX 500**
Quench and tempering steel
- OvaX 600**
Through hardening steel
- OvaX 800**
Through hardening steel



OVAKO

Ovako Hofors AB
SE-712 80 Hallefors,
Sweden
Phone: +46 591 60 138
Fax: +46 591 60 606

Ovako North America, Inc.
1096 Assembly Drive, Suite 312
Fort Mill, SC 29708, USA
Phone: +1 803 802 1500
Fax: +1 803 802 1501

www.ovako.com

ALLEGHENY TECHNOLOGIES LTD

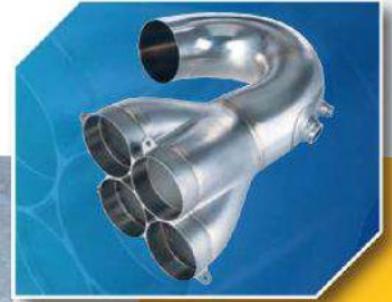

TITANIUM FROM STOCK

Allegheny Technologies Ltd is the leading dedicated Titanium supplier to the motorsport industry worldwide.

Our customer base covers all levels of motorsport from Formula 1 through to weekend racers. We hold extensive stocks of CP and 6Al/4V titanium bar, billet, plate and sheet, complimented by specific stocks of Titanium Alloy 6246 & 38-644 bar, 3Al/2.5V seamless tube and Nickel 625 sheet. Cutting to size and in house waterjet profiling available. Full material traceability under our ISO9001 quality system is supplied with all products. Total metallurgical and engineering support is available from Allegheny Technologies Ltd experienced team of motorsport's specialists.

Please visit our website at: www.atimetals.co.uk/titanium
Alternatively you can email us at: nigel.hoskison@atimetals.com



On the brakes

In the first part of our in-depth look at the state-of-the-art in racecar brake technology, we focus on calipers and cooling

The Formula 1 technical regulations on brakes are so tightly defined that teams are told how many bolts can be used to attach the caliper to the upright, the maximum number of pistons that can be used in the caliper, the number of pads that can be fitted in the caliper, the diameter and thickness of the brake discs and even the modulus of the material that can be used to make the caliper.

An 80Gpa modulus of elasticity limit for the caliper

BY ALAN LIS

material effectively only allows the use of a good grade of aircraft-quality aluminium so, under current regulations, a lithium-aluminium alloy is considered the best material. In practice, this means the teams have the option of either adding weight to make the caliper stiffer or making it lighter and, in doing so, running the risk of making it more flexible.

'The design of a Formula 1 brake caliper is quite a lengthy process and one that we have

been going over and over for a number of years with various materials,' says AP Racing's Steve Bryan. 'We put an awful lot of effort into FE analysis and the use of software design aids. Typically, those computational tools tend to come up with a 3D model that is impossible to manufacture by known methods but gives our design guys some inspiration.'

METAL MATRIX COMPOSITE

The modulus limit introduced at the end of the 2000 F1 season was aimed at stopping the use of

ever more exotic and expensive materials, such as beryllium-aluminium alloy. With a silicon carbide-aluminium metal matrix composite (MMC), AP Racing found that it was possible to make an exceptional performing caliper (some 40-50 per cent stiffer), but one that was about 25 per cent heavier than a conventional aluminium caliper. This compromise the teams were prepared to accept. However, had beryllium aluminium been allowed, it was possible to achieve comparable stiffness to the MMC caliper but with less

weight than the conventional aluminium caliper. There were drawbacks, though.

'The main one being that beryllium is carcinogenic,' explains Bryan, 'so machinists working with the material had to be specially licensed, the machines they were using had to have dust extraction systems fitted and the dust they collected had to be disposed of as hazardous waste, which added to the expense of production. On top of that, the cost of the material itself was astronomical. When we were making beryllium aluminium calipers they were being sold at around £7000 (\$11,270) each - way, way more than anyone was used to paying.'

MONOBLOC DESIGN

Since then, caliper weight savings have instead had to be achieved by advances in design and manufacture. 'A current Formula 1 caliper is, structurally, fairly skeletal compared with one from 10 or 15 years ago, and it's more expensive to manufacture because it's made as a monobloc piece without a



The quest for greater speed and efficiency, together with improvements in simulation and materials technology, has driven down the size of calipers, as evidenced by comparing these 1996 calipers with the one below

bespoke caliper configuration, and in recent years AP Racing has, in effect, been providing a caliper design and manufacturing service: 'We bring our ideas and experience to the table,' says Bryan, 'and the teams will say where they want to be on the stiffness vs weight curve as they may have strong views on, for example, wanting to reduce corner weight to the maximum degree. The process will also have to take into account design



F1 calipers are limited to three pistons either side of the disc, generally of varying sizes to ensure even pressure is exerted along the pads' length

each team evolved its own bespoke caliper configuration

joint line,' explains Bryan. 'All the bores have to be machined from the inside out with geared heads, so it's a bit fiddly. Over the years we have invested in a lot of machinery and we have got better and better at doing it, so now it's not a technology problem; it just costs a bit more. But, of course, F1 is about finding the best possible engineering answer to suit the regulations, and that's the best solution.'

Until the beginning of this century, the F1 brake caliper manufacturers supplied off-the-shelf calipers to the teams (and indeed, in 2010, AP Racing designed and manufactured a 'generic' F1 brake caliper (CP6380) for some teams) but, as F1 technical regulations became ever-more restrictive, performance advantages were sought in *all* areas of the car. As a result, each team evolved its own

constraints, such as wheel profiles and the shape of the wheel spokes because that can vary from one car to the next. Typically, it's easier to make a lighter wheel with straight spokes, because they are stiffer, but straight spokes mean less space for the brake caliper, so there is a trade off to be made there. You need to have your brave trousers on to do that, because once you've committed to 100 sets of wheels it's not easy to change back again.'

It's also necessary to take into account a team's philosophy on brake cooling and incorporate a number of hard points into a caliper design for the mounting of ducts and carbon fibre drum brake shrouds. A team will also define the mounting angle of the caliper, which will largely be determined by the position of the suspension pick ups on the

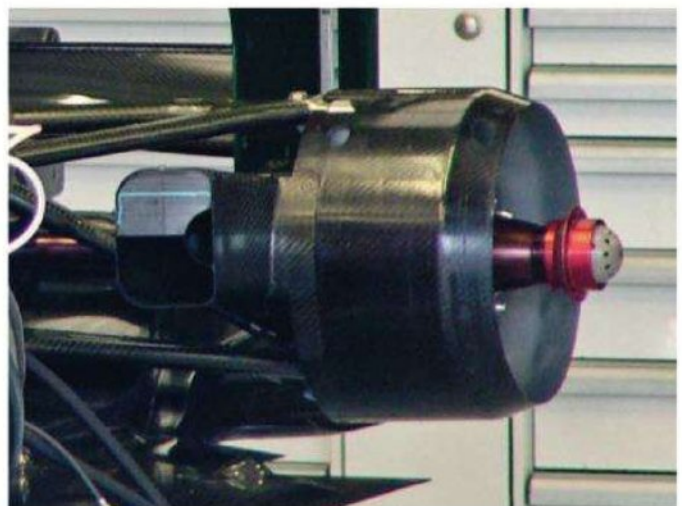

Carbon ducting and shrouds are an integral part of an F1 car's brake package

upright, as the distribution of those three points typically leaves only one space large enough to fit it. This may be horizontally at the bottom of the upright or angled at the front or rear.

HYDRAULIC CONSIDERATIONS

Formula 1 brake calipers have three pistons on each side of the disc - the maximum allowed by

technical regulations - although there is no limit on piston area. 'The hydraulic side of the caliper really builds itself,' says Bryan. 'Typically, an F1 master cylinder has a diameter of 0.7in (1.8cm), which would not be unusual for a road car, and you end up with a pedal ratio of somewhere between 3:1 and 4:1.'

If you wanted to generate



A decade ago F1 teams simply bought calipers off the shelf, but these days almost all teams have calipers made to their own design and specification

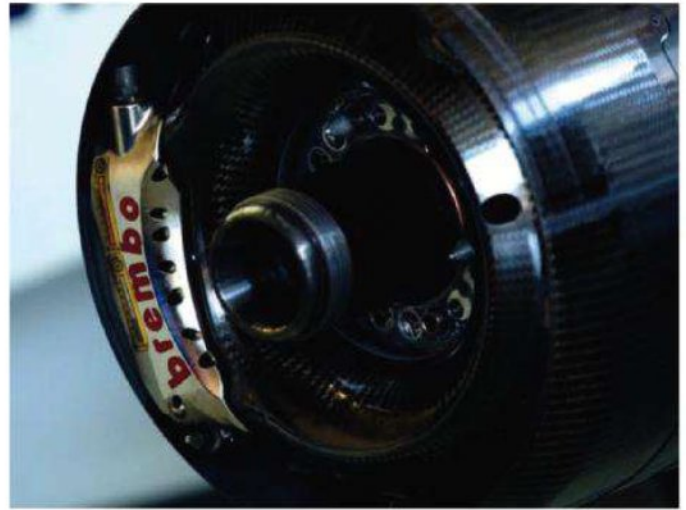

Manufacturers need to work closely with teams from the start of the design process to deal with cooling packages and mounting requirements

With extremely limited space for travel, the ratio between master cylinder bore and pedal length is critical. A typical F1 master cylinder has a bore diameter of 18mm (0.7in)

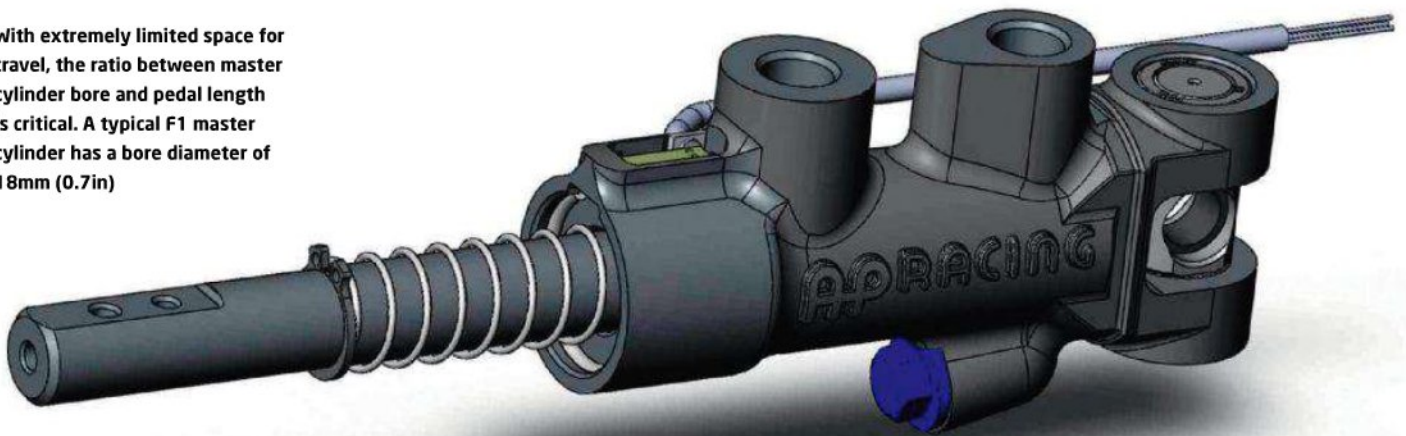

higher pressure you would go for a smaller master cylinder, but the downside of that is that you would need a lot of travel and that's something that can't easily be accommodated in an F1 car. You are limited in the length of the pedal in an F1 car (usually by the length of the driver's foot). In that length, you have to accommodate a pivot and then the master cylinder pushrod arrangement.

'The area around the pedals is very cramped with bulkheads, suspension parts and other pieces. It's almost inevitable that after 30-40mm of pedal travel, the driver's toes will come into contact with something.' Also, the driving position in an F1 car means that a driver's ankles are in a position where they run out of efficiency

quite quickly, so essentially he is just flexing his ankle when he operates the brake pedal. This means there is a limit on the lever ratio and the amount of pedal travel that the driver can accommodate before it becomes

there is a limit on the lever ratio and the amount of pedal travel

a problem. 'That tends to dictate the hydraulic ratio because the next lever is obviously the area ratio between the master cylinder and the pistons in the caliper, and the driver has to be able to generate enough force on the pads to stop the car,' continues Bryan.

PISTON SIZES

'You could use very large pistons and low pressures, but the problem with that is that the design of the caliper is governed by other considerations. The outside edges are governed by the need to fit

them is split into three so the load is applied down the length of the pad. If the piston diameters were larger, the body of the caliper would be deeper and it would be difficult to make it light. Also, if the piston centrelines move down too far away from the caliper bridges, the whole structure will want to open up as load is applied. Like everything else on a racecar, the design of the caliper is a series of compromises.

Several factors determine the ratio between the piston bore sizes, including a certain amount of calculation and quite a lot of experience as well. 'If we suddenly got thrown a quite different friction material, we might have to re-evaluate, but generally you are trying to keep the pad wearing relatively flat,'

inside a 13in wheel, the width is governed by the wheel spokes and the pads need to be of a certain area and thickness in order to get the required performance and wear rate.' Consequently, F1 brake pads are longer than a conventional pad and the piston area behind

ECU/Exchange Loom/Throttle Body Packages available

Complex modern engine? We can manage it

ECU solutions for:
Honda S2000 and K20A
Ford ST170 and Duratec
Toyota 2ZZ
BMW Single / Twin VANOS
Audi 1.8T and 5 cylinder
Chevrolet LS7.

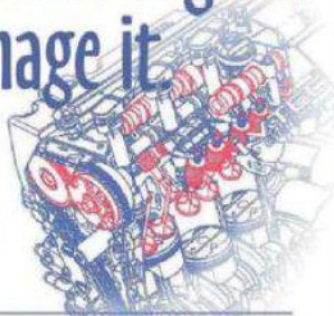

Our ECU's are capable of dealing with the most complex of modern engines without the need to change sensors or sacrifice key features such as variable camshafts.



S series

Get the very best from any engine and from only £495.00 + VAT.

DTAfast, 10 Boston Court, Kansas Ave, Salford M50 2GN
Tel: +44 (0)161 877 1419 Fax: +44 (0)161 877 7086
Email: office@dtafast.co.uk Website: www.dtafast.co.uk

POWER POWER POWER POWER
STEER STEER STEER STEER
WOODWARD

CUSTOM BUILT POWER STEERING Racks and Components

SERVING MOTORSPORT WORLDWIDE
from one-off specials to entire racing series

IN USA: **WOODWARD** PRECISION POWER STEERING
woodwardsteering.com

IN EU: **HYDROLINE** PRECISION POWER STEERING
hydroline.nl

Casper, Wyoming phone 1 307 472 0550 fax 1 307 235 1551

Zeewolde, The Netherlands phone +31 36 538 72 80 fax +31 36 522 74 59

Heavy-duty spherical bearings and rod ends for motorsport

Certified as per EN 9100!

- The art of performance
- Driven by quality
- Power – Precision – Passion
- Smart way of moving



HIRSCHMANN

HIRSCHMANN GMBH · D-78737 Fluorn-Winzeln
Phone: +49 (0) 74 02/1 83-0 · Fax: +49 (0) 74 02/1 83-10
www.hirschmanngmbh.com · info@hirschmanngmbh.com

NEW: CAN DISPLAY



KMS Kronenburg Management Systems



Kronenburg Management Systems (KMS) is a complete line of engine management systems, that offers you an extremely reliable and user-friendly system at a very competitive price. It gives you the possibility to manage all (turbo + n/a) petrol engines up to 12 cylinders with options such as 4mb datalogging, staged/banked injection, mapselector, odd firing, self-learning lambda control, boost control, variable launch control, idle control, traction control, powershift, rpm limiters, engine diagnostics, shift-light, water injection, cooling fan, fuel pump, etc. New KMS CAN display, UEGO CAN controller and MAP sensors now available.

For more information, free software and prices:

<http://kms.vankronenburg.nl>

KMS Kronenburg Management Systems

KMS Management Systems
Spaarpot-Oost 19, 5667 KT Geldrop, The Netherlands
T. +31(0)402854064, F. +31(0)402867765
E. info@van-kronenburg.nl

explains Bryan. 'The problem is that when the brakes go on, the pads are forced against the abutments at the trailing end of the caliper, so there is a big force there. Rather than the pad sliding out parallel, it will try to pivot about the trailing edge.'

To overcome this, the pistons increase in size along the length of the caliper in an effort to introduce the face of the pad parallel to the surface of the disc. 'If you didn't do that, you would have severe longitudinal taper wear. The driver would start the race with a good hard pedal because the pistons are contacting the back of the pads nice and square but, if the pad tapers, the piston will be pushed back by the thick end of the pad and there will be daylight at the other end. So when the brakes are applied, the uneven movement of the pistons will make the pedal softer and softer.'

'The pads also tend to taper radially so that they wear more on the outside edge than the inside edge, which is largely a factor of the rubbing speed. There's not a lot you can do about that other than avoid a very deep pad.'

CARBON-CARBON

When carbon-carbon brake discs and pads were first introduced in F1 in the mid-1980s, the caliper manufacturers fitted seals to the back of the pistons. This was done to try and keep the fluid away from the heat generated by the pads and discs, and various insulating materials and plates were also employed. 'Over time that's all been simplified,' says Bryan. 'We now have a fairly conventional square section caliper seal that performs a number of functions - obviously it stops the fluid escaping, but it also controls piston movement. It pulls back the piston a tiny amount when the brakes come off to minimise the drag inherent in the system. It also has enough grip on the piston that vibration, say, from bouncing over a kerb, doesn't knock everything backwards and push the pistons back into the caliper leading to a long pedal.'

The design of the square section seal and the groove that it moves in are closely guarded



The service life of an F1 brake caliper has more to do with the thermal cycling that the caliper sees than the mileage over which it is used

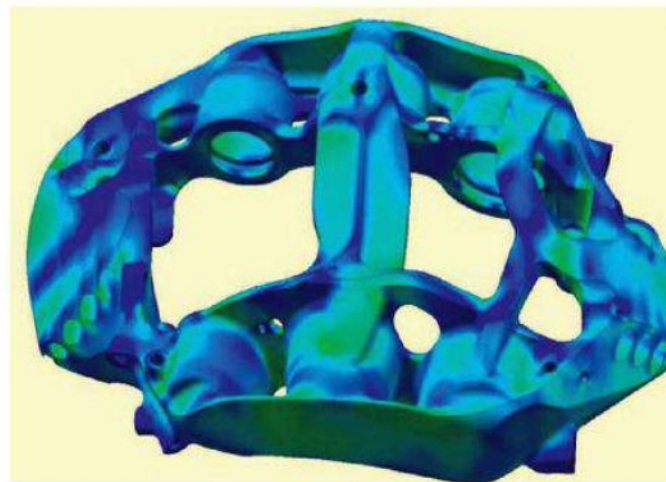

With material type limited, there is always a trade off between caliper rigidity and weight, so much of the development work is done with FEA

secrets, but Bryan admits that the pistons used in AP Racing calipers are made from titanium and have an undisclosed anti-galling coating. 'Titanium doesn't always work happily with other metals, so we use what is

make calipers too hot, they start to over-age and the tensile strength and hardness starts to diminish,' observes Bryan. 'Over a period of time they will get slowly weaker and eventually they can crack. Because the alloy

Generally, the stiffer the caliper the better for a firm pedal

effectively a sacrificial coating on the pistons that acts as a lubricant. It does wear through eventually, but the pistons can be re-coated.'

The service life of an F1 brake caliper has more to do with the thermal cycling that the caliper sees than the mileage over which it is used. 'If you get the grades of aluminium that are used to

has lithium in it, which has a granular structure, you can get inter-granular cracks. What you will find is a small bead of fluid on the outside of the caliper body, because each time the pressure goes on, fluid leaks out. In a lot of cases, when a crack first appears the driver will not even be aware of it because it's so small and the loss of

fluid is so slight that it doesn't make any difference to what he feels through the pedal. But if you take a wheel off and the caliper is a bit sweaty, you know something is not right. Then, if you look long and hard enough, you will eventually find a small crack. Typically, that happens after 8000-9000kms, so we set 7000kms as a reasonable service life target, but if a caliper is put through a lot of thermal cycles it can happen much sooner.'

SYSTEM STIFFNESS

As ever the rigidity - or otherwise - of the caliper is a major contributing factor to pedal feel, and consequently confidence for the driver. It goes without saying that there are a number of losses within the braking systems that all add up, and a team will sometimes opt to trade system stiffness for system weight. But equally obviously, there is a minimum acceptable stiffness before pad wear becomes uneven and the driver won't be able to cope. Conversely, there will also be a maximum acceptable weight that a team will be willing to compromise on. Within those bounds, there is a degree of freedom and driver preference will have an influence. 'We have had instances where a team has developed its system along with the preference of a number one driver who has been able to cope with quite a long pedal and gone down the route of making the caliper lighter and lighter,' says Bryan, 'but of course, when that driver moves on and there is a new number one, his preference might be completely different. Generally, the stiffer the caliper the better for a firm pedal, which is a big confidence factor for most drivers. But, at the same time, the engineers are always looking to save a gram here and there.'

So how does the stiffness and weight of a 2011 compare with, say, a 1991 caliper? Confidentiality agreements with AP Racing's customer teams mean that Bryan is unable to quote precise figures, but he observes that the stiffness of the 'generic' F1 caliper is probably in the same ballpark. 'In the case of some of the bespoke calipers, though, it's a good deal better,' he

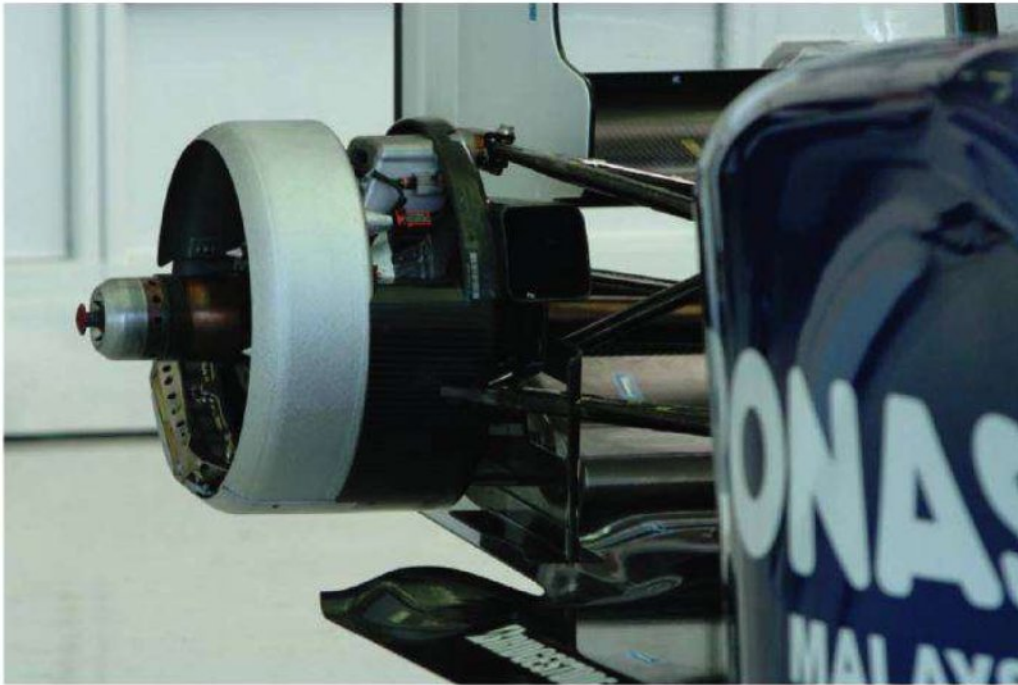

Since the introduction of carbon carbon brakes, almost as much development work goes into brake cooling as into the brakes themselves, but...

says. 'The big difference is that they are all quite a bit lighter, by 200-300g. Without pads, our current generic caliper weighs around 1.4kg.'

BRAKE COOLING

When carbon-carbon brakes were first used in Formula 1 there were issues with the efficiency of brake cooling systems, but 25 years of development has seen them evolve to a degree that such problems are now largely a distant memory. 'In the early days of carbon brakes, the teams would make their uprights from fabricated steel or cast aluminium and buy in their calipers,' recalls Bryan. 'Then they would bolt it all together and, almost as an afterthought, they'd make a glass fibre duct, strap that on and hope it would all work.'

'Nowadays, an awful lot of CFD and aero work goes into making sure the brakes are properly cooled. When we sit down with a team to design a caliper, there are inserts incorporated into the piece so that various bits of carbon fibre ducting can be fastened on. Some of the teams we supply come to Coventry to use our dyno because they can't go track testing. If you optimise everything and use all the potential in the cooling airflow, you can have the smallest



...looking from this angle, it's not hard to see why calipers easily overheat when a car comes to a stop out on circuit, as the shroud acts like an oven

possible duct. The teams pursue that, not because it makes life easier for the brakes, but because overall it's a potential performance gain.'

Bryan asserts that generally, brake cooling in F1 hasn't been a major issue for many years and that if a problem does occur, it will usually be high rear caliper temperatures at certain circuits: 'Places like Monaco and Singapore can be bad in that regard because the drivers are on the brakes quite a lot and there isn't much of a run in between applications to cool things down. The rear brakes are always more difficult to cool than the fronts. At the front of the car you have

the potential to position the duct in high pressure clean air. At the rear you can't get away with the old periscope ducts that were used on the cars in the 1970s, so nowadays ducts have to be small and operate in turbulent air. On a circuit where there is no respite, rear caliper temperatures can climb above 250degC.

'What really kills off a caliper, though, is when a car stops out on a circuit. You'll notice that whenever a car comes into the pits there will be four guys with leaf blowers directing air into the brake ducts. As soon as the flow of cooling air stops and the brakes are hot, the caliper temperature starts to spike so,

if a car stops out on the circuit, the calipers get a good cooking because they are enclosed by the ducting and drum, which form a nice little oven with the red hot discs and pads.'

The good news, at least as far as brake manufacturers are concerned, is that the increased start-line weight of the cars under the no in-race refuelling rule introduced in 2010 had little effect on the demands made on their brake systems. 'The ducts had to be a bit bigger and everything had to be working a bit more efficiently early in the race,' says Bryan, 'but the Bridgestone tyres that were used until the end of 2010 were notable for giving almost the same grip when they were 50 laps old as when they were new. If there hadn't been a rule requiring each driver to use both types of tyre in a race, I'm quite

“ brake cooling in F1 hasn't been a major issue for many years ”

sure many drivers would have been able to have finished races on one set of tyres.

'It doesn't seem that it will be that way in 2011 with the Pirelli tyres, though, so there could be some braking issues with cars starting on a heavy fuel load and new tyres, compared with cars at the end of a race when the car is low on fuel and the tyres are just about shot. The cooling requirement for the brakes is going to be vastly different in those cases. It could cause problems at some circuits where, depending on the friction material being used, the driver could find the brakes a bit difficult because they are being over cooled.'

Only time will tell but, for the time being, Bryan seems confident that AP Racing has the best solution to the current problem - that of bringing the pinnacle of motor racing technology to a stop, in a safe and controlled manner.



SOLID STATE BATTERY ISOLATORS

Reliable, affordable, used by professionals



Developed specifically for motorsport use the Solid State Battery Isolator from **CARTEK** is a major advance in the safety and reliability of race cars.



Fully electronic with no moving parts, and cemented into an aluminium shell, makes this system highly resistant to shock, vibration, moisture and dirt.

Using the latest MOSFET technology this system provides safe, spark-free isolation of the vehicle's battery and engine electrics in accordance with FIA and MSA regulations.

NEW FIA Rain Light

CARTEK now produce the smallest and lightest rain light that meets the latest FIA specification for size, intensity and viewing angle.

Future Proof.

Solid, robust construction with 2x M6 studs.

Can be mounted vertically or horizontally.

Available static or 3Hz flashing.

56mm x 90mm x 15mm, 153g, 0.2Amps, 200cd

FIA Homologation No: MSA/RWL/33/10



www.CARTEKMOTORSPORT.com

CARTEK AUTOMOTIVE ELECTRONICS LTD

Tel: +44(0)2380 637600 Email: info@cartekmotorsport.com



Fitting & Hose Systems

...one step ahead

Steering wheel quick release



- Only 272g
- Conical seat - free from play
- Easy to connect by ingenious mechanism

Bespoke parts

- CNC turning and 5-axis milling machines
- short delivery times
- full traceability



High quality hose assemblies

- All race series F1, ALMS, WTCC, WRC
- 100% pressure tested
- flushed to NAS on request



CUSTOM BRAKE LINES | OIL COOLERS | HOSE | FITTINGS
ADAPTERS | FILTERS | NOS | FUEL PUMPS & REGULATORS



FUEL LAB NOS Holley EARL'S WOODS STAUBLI

Visit www.earls.co.uk for the full range
Online Shop now Available

Earl's Performance Products UK Ltd

Units 15-16 Silverstone Circuit, Northants, United Kingdom NN12 8TL

+44(0)1803 869850 | sales@earls.co.uk

QUOTE "RCE10"
WHEN ORDERING TO
RECEIVE 5% DISCOUNT

New facility in the UK

KRONTEC Design Ltd., Phone: +44(0)17 93-42 20 00

www.krontec.com

TOTAL SEAL®

High Performance
PISTON RINGS

The Leader in Piston Ring Innovation & Technology...

Total Seal® Advanced Profiling™ Steel Rings

- Stronger and Longer Life – Most Precise Tolerances
- Thinner – Flatter – Lighter
- Conforms Better to the Cylinder Wall
- More Face & Anti-Friction Side Coatings
- Custom Sizing – Specialized Face Profiles
- Available In Gapless®, Napier or Conventional Styles

AP
**ADVANCED
PROFILING™**
STEEL RINGS

Total Seal® Diamond Finish™ Rings

- Tolerances of $\pm .000050''$
- Improved Sealing Between Piston and Piston Ring
- Optional PVD Coatings
- Custom Axial Thickness Down to .6mm
- Available In Gapless®, Napier or Conventional Styles

Total Seal® Gapless® Top** or 2ND Rings

- Increased Horsepower and Torque
- Wider Torque Curve
- Longer Engine Life – Fewer Teardowns
- Improved Consistency – Longer Ring Life
- Cleaner, Cooler Engine Oil – Better Oil Control
- Less Friction – Increased Horsepower
- Increased Intake Signal – More Engine Vacuum

** Patented

If you've got a ring problem, we offer the technical expertise and assistance to help give you the winning edge!

Home of the Gapless® Piston Ring

Total Seal® pioneered this horsepower producing technology over 40 years ago and has been perfecting it ever since. Available in both our patented Top or 2nd ring applications.

TotalSeal.com
800-874-2753
Tech Line: 623-587-7400



Available in the UK from:

PERFORMANCE UNLIMITED
3, Chessingham Park
Dunnington, York
North Yorkshire, YO19 5SE
England

Phone +44 (0) 1904 489332
Fax +44 (0) 1904 488355
e-mail info@performanceunlimited.co.uk
www.performanceunlimited.co.uk

Pseudo-static vs transient

Clearing up some of the common confusion between two different methods of lap time simulation

Like it or not, lap time simulation is becoming an increasingly important part of the motorsport landscape. Over the last couple of months, I have been speaking to a number of different race teams over multiple continents in very different categories. What has struck me during these conversations is that while there is recognition that there is a need for lap time simulation, there is a great deal of ignorance about how it works, what different methods are available and why these

BY DANNY NOWLAN

differences are so important.

This article will outline the differences between the two industry standard methods - pseudo static and transient lap time simulation. I have been very wary of writing this article for *Racecar Engineering*, on the simple principle that because I run ChassisSim, I have a significant vested interest. However, the reason I am writing this feature is that over the last couple of months I have been astounded by the lack of

understanding about what lap time simulation really is. And as a race / data engineer myself, as well as a simulation developer and end user, I feel I'm in a pretty good position to explain.

The goal of this article is to highlight *why* the differences between these two methods are so significant. As we will outline, the differences between these two methods are stark. Indeed, when ChassisSim was first starting to come together 15 years ago during my Masters, I considered the pseudo-static route. However, after reviewing

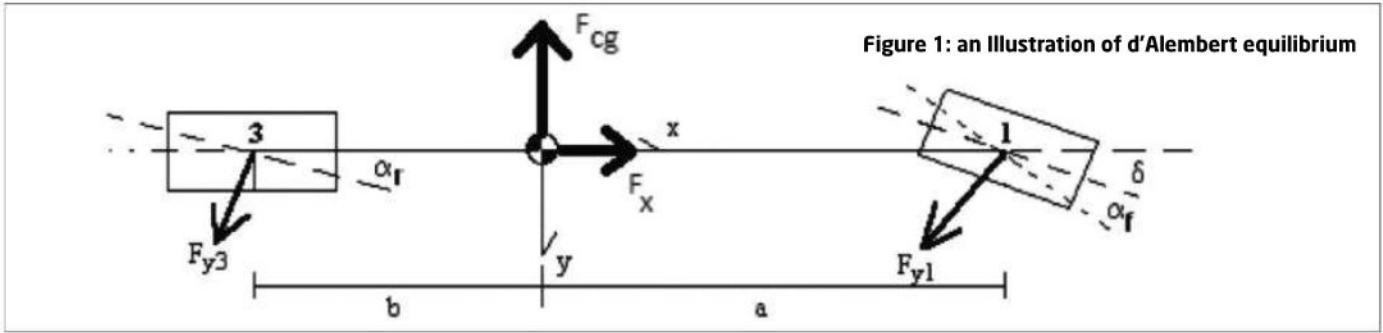

Figure 1: an illustration of d'Alembert equilibrium

it for 15 minutes, I rejected it out of hand, for reasons I will explain here. Once you understand the reason for this, it will fundamentally change the way you think about simulating racecars. I've seen this transition happen throughout the ChassisSim user community.

To start this discussion then, let's review pseudo or quasi-static simulation. This approach to simulation has its origins in the d'Alembert equilibrium assumption, illustrated above in figure 1.

As you can see with our bicycle model, the aim is for all the forces to balance out. This way, all the forces and moments add up to zero, which reduces the model to a static case so that we can deal with it easily. Consequently, at the c of g we place a force equal and opposite to the way we are going. This is given by,

$$(1) \quad F_{c.g} = \frac{m_t \cdot V_x^2}{R}$$

Where,
 $F_{c.g}$ = force applied at the c of g (N)
 m_t = total car mass (kg)
 R = radius of the corner (m)

The d'Alembert approximation is an excellent first step in starting to understand transient and dynamic behaviour. The advantages of this approach are twofold:

- 1) it's an excellent tool for structural analysis
- 2) it gives the engineer a method for doing hand calculations to approximate tyre forces and other vehicle dynamics behaviour.

What pseudo-static lap time simulation does is use the d'Alembert approximation to estimate what the car will do over the lap, effectively applying a force balance at many different points over the lap. The guts of pseudo-static lap time simulation can actually be approximated

$$(2) \quad F_{avail} = \frac{wdf \cdot m_t \cdot V_x^2}{R}$$

$$F_{avail} = Fm(L_1) + Fm(L_2)$$

using a spreadsheet. Let's consider a front force balance, where we have the following: Where,
 F_{avail} = maximum lateral tyre force available from the two tyres
 L_1 = load on the front Left tyre
 L_2 = load on the front right tyre
 $Fm(L)$ = maximum lateral tyre force for a given load
 m_t = total car mass (kg)
 R = radius of the corner (m)
 wdf = front weight distribution (percentage / 100)
 V_x = forward vehicle speed (m/s)

The Fm term is effectively the D term of a Pacejka model, or the ChassisSim tyre model traction circle radius vs load function. Obviously, this term is affected by cambers and traction circle radii, but this is a pretty good start. Re-arranging equation (2) our speed can be given by:

$$(3) \quad V_x = \sqrt{\frac{F_{avail} \cdot R}{wdf \cdot m_t}}$$

Equations (2) and (3) are the guts of pseudo-static lap time simulation. We get the

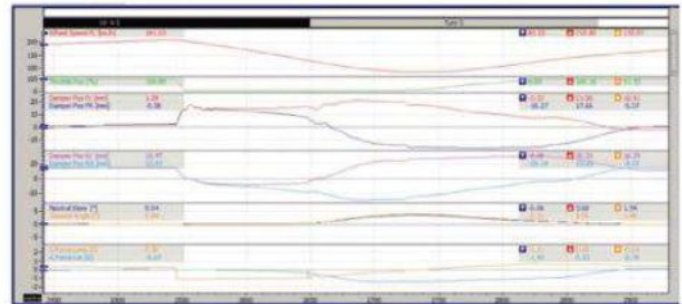

Figure 2: an example of what to expect from pseudo-static simulation

peak corner radius, ramp up the speeds, work out the load transfer and iterate until we find a force balance. In reality, as we start to take into account cambers, mixed tyre force conditions, compliances and suspension geometries and aero effects, we need specialist computer code because things become tricky. However, the crux of the technique is still just applying a simple force balance, as outlined in equations (2) - (3).

When we have completed all these force balances, we then piece the lap together. This results in a simulated lap that will look something like figure 2.

As we can see, the damper traces are all changing slowly from point to point, so it gives us a good approximation of what to expect from our racecar. This method does the following very well:

- Since it is static, it executes quickly
- It does a reasonable job of looking at wings
- It is good for looking at gear ratios

To consider the interactions of different set-up variables, pseudo-static lap time simulation is a good start point. But is it the complete story?

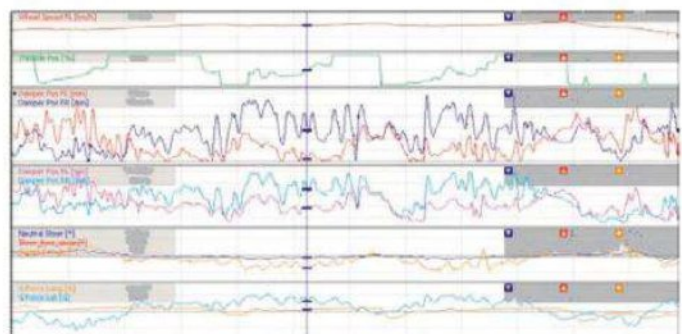

Figure 3: actual data from a racecar going through a corner

Table 1 V8 Supercar set-up variables	
Set-up variable	Value
Front spring wheel rate	70N/mm
Front tyre spring rate	320N/mm
Downforce (CLA)	1.0

Table 2 relative comparison of suspension roll for pseudo-static roll calculation vs actual data

	Pseudo-static	Actual data
Front	1	1.11
Rear	1	1.13

Let's have a look at some actual data of a car going through a corner. This is illustrated opposite below, in figure 3. The particular car in question is a V8 Supercar with the parameters shown in table 1.

As we can see, there is some significant variation in the dampers as the car is going through the corner. Given that the road spring rates are significantly less than the tyre spring rates, the damper movement is a pretty good indication of tyre load. Let's see how our pseudo-static assumptions add up by comparing the roll for the pseudo-static case with the actual case. Unfortunately, due to confidentiality I can't give you the actual numbers, but I will compare magnitudes. Comparing the pseudo-static roll with the actual data, we have the results shown in table 2, above.

This isn't bad and gives us an indication of what to expect. However, while our pseudo-static assumption has got us close, what we are missing is the transients.

Let's illustrate this by considering the relative force between the compression of a damper and the associated damping velocity. For the sake of argument, let's say we have the data illustrated in table 3, below.

What this illustrates is the fact that the spring accounts for the bulk of the force in the spring / damper unit. However, you would be foolish to ignore the damper contribution, which is in the order of 20 per cent of the spring rate. Table 3 also indicates that transients play as much of a

role in what a racecar is going to do as the springs, bars, dampers and wings.

Where pseudo-static lap time simulation runs out of steam is that it doesn't take into account the kind of transients illustrated in tables 2 and 3. Yes, it will give you a fair picture of what to expect with your racecar, but it can't fill you in on what to expect as you transition from one state to another as you progress through the corner. And the vehicle changes state from braking through turn in to mid-corner, and eventually to exit. Unfortunately, these transient influences make all the difference in setting up your car. Also by definition, pseudo static lap time simulation can't deal with bump, and this has a massive impact on the set up.

For those of you who think bumps and transients are irrelevant on a high-downforce

(4)

$$m_s \cdot \ddot{\theta} = F_{aerof} + F_{aerov} + m \cdot g - k_f(z - a \cdot \theta - x_d) - c_f(\dot{z} - a \cdot \dot{\theta} - \dot{x}_d) - k_r(z + b \cdot \theta - x_v) - c_r(\dot{z} + b \cdot \dot{\theta} - \dot{x}_v)$$

$$I_y \cdot \ddot{\theta} = a \cdot (k_f(z - a \cdot \theta - x_d) + c_f(\dot{z} - a \cdot \dot{\theta} - \dot{x}_d)) - b \cdot (k_r(z + b \cdot \theta - x_v) + c_r(\dot{z} + b \cdot \dot{\theta} - \dot{x}_v)) + (h - pc_f) \cdot F_{zf} + (h - pc_r) \cdot F_{zr}$$

$$m_d \cdot \ddot{x}_d = k_f(z - a \cdot \theta - x_d) + c_f(\dot{z} - a \cdot \dot{\theta} - \dot{x}_d) + m_d g - k_d(x_d - z_{br}) - \frac{F_{zf} \cdot pc_f}{a}$$

$$m_v \cdot \ddot{x}_v = k_r(z + b \cdot \theta - x_v) + c_r(\dot{z} + b \cdot \dot{\theta} - \dot{x}_v) + m_v g - k_v(x_v - z_{br}) + \frac{F_{zr} \cdot pc_r}{b}$$

car, think again. Then look at figure 3. This may be a low-downforce car, but translate all that damper movement to a ride-height sensitive aeromap. If you can't control the variation of your ride height, your driver is going to have a wild ride through

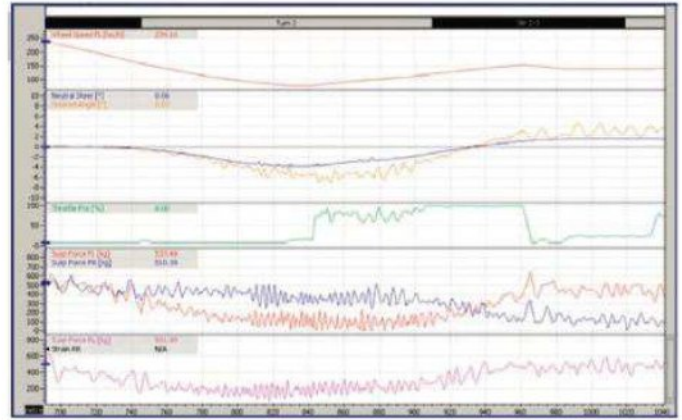

Figure 4: tyre load variation through a corner

the corner. Think of this another way - F1 teams didn't spend fortunes on active suspension for no good reason...

Also, remember that tyre load variation counts almost as much as the average tyre load through a corner. This is illustrated in figure 4. As we can see, the variation shown here is quite significant, and we all know tyre load is a direct indicator of how much force we have available from the tyre. While this is a bumpy corner, it nonetheless has massive implications for how you drive the corner. You would have to be pretty brave to say you could approximate this using

perfectly smooth and the vehicle parameters are changing slowly, pseudo-static assumptions will approximate equation (4). However, the minute you have either bumps or any transient behaviour (which is just about everything we do on a racecar) these pseudo-static assumptions are no longer applicable.

To illustrate why the transient approach is so important, we need to consider what the tyre loads on the racecar look like, and how they impact on vehicle performance. To illustrate this, the tyre loads on the racecar are given by the following,

a static assumption, but we'll discuss this in more detail shortly.

Transient lap time simulation uses the full equations of motion of the car to nail down both the transient and steady-state behaviour of the car. As we can see from figure 4, the two are very closely related and you can not take one into account without the other. To give you a taste of what you are dealing with, equation (4) presents the full equations of the bicycle model of the racecar.

While I don't intend to go into outlining each of these terms, when the track is

$$L_1 = ktf(z_1 - y_1) + ctf(z_1' - y_1')$$

$$L_2 = ktf(z_2 - y_2) + ctf(z_2' - y_2')$$

$$L_3 = ktr(z_3 - y_3) + ctr(z_3' - y_3')$$

$$L_4 = ktr(z_4 - y_4) + ctr(z_4' - y_4')$$

Where,
 L_i = each individual tyre load
 ktf = front tyre spring rate
 ktr = rear tyre spring rate
 ctf = front tyre damping rate
 ctr = rear tyre damping rate
 z_i = individual track surface variation
 y_j = individual wheel movements

(6)

$$F_y = k_a(1 - k_b \cdot F_z) \cdot F_z$$

Table 3 Illustration of spring and damper forces

	Spring / damper velocity	Spring rate / damping force	Force (N)
Damper movement	30mm	80N/mm	2400
Damper velocity	50mm/s	400N	400

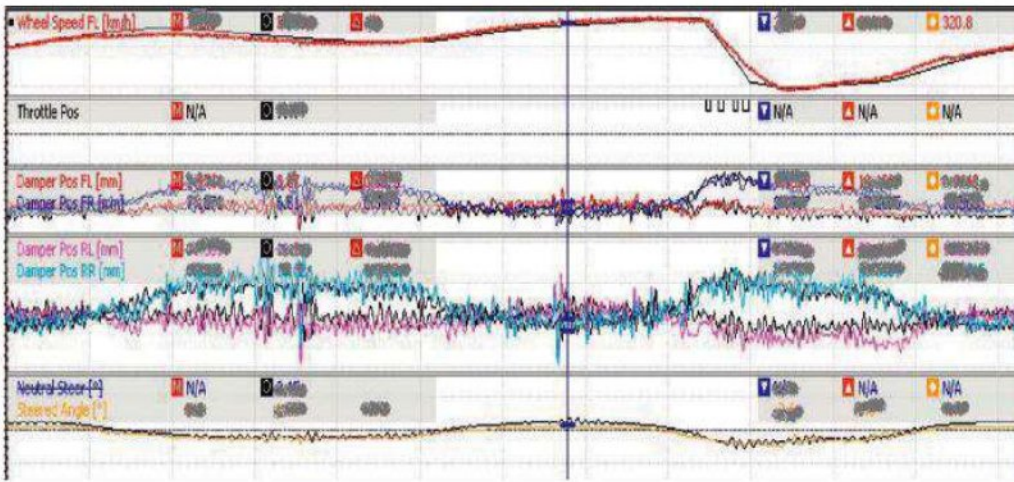

Figure 5: actual data vs simulated data on a high-speed oval using transient lap time simulation

The best way of thinking about wheel movements is to say it is effectively individual ride heights subtracted by individual damper movement. The dashes represent derivatives. To put this into perspective, the maximum tyre force or the cornering potential of a tyre can be approximated by equation (6). Where,

$$k_a = \text{initial coefficient of friction}$$

$$k_b = \text{drop off of coefficient with load}$$

$$F_z = \text{load on the tyre}$$

Even though equation (6) is an approximation, it nonetheless illustrates just how significantly tyre force will vary as a result of bumps and other transient behaviour. This is due to the fact that movements in the chassis translate directly to wheel movements, which in turn will lead to changes in tyre loads that can be evaluated using equation (5). As illustrated, change in tyre loads will lead to significant changes in tyre lateral force, and that can be approximated using equation (6).

Your tyre force is fundamental to the corner speed, and this will have a massive impact on vehicle performance. This is the principle reason why I rejected pseudo-static lap time simulation when I started to put ChassisSim together 15 years ago.

There are some who might say that approximating this with an average tyre load will suffice for performance simulation, but does this really add up? To find out, let's return to figure 4, in light of what we have just discussed. The average tyre

load at mid-corner in figure 4 is approximately 400kg for the outside front and 120kg for the rear. Yet at mid-corner, we are seeing minimum values of 350kg for the outside tyre and 30kg for the inside as we go over the bumps. To quantify this, let's

not all lap time algorithms are created equal

assume we have a car weight of 550kg, a weight distribution at the front of 41 per cent and an initial coefficient of the tyre of 1.5 (k_a) and a drop off of 5×10^{-5} (k_b). Using equation (6), for our smooth assumption we are looking at a cornering potential of 2.89g. Yet looking at the actual loads, the cornering potential is 2.12g, where we have our minimum load! This differential at mid-corner will have massive implications for what the car is going to do, let alone for driver confidence. Put another way - let's say the corner radius is 40m. Using our static prediction, we should be able to take the corner at approximately 120km/h. However, our tyre loads are telling us there are some points at the mid-corner of the turn where we only have sufficient force to take the corner at 104km/h. Again, you would have to be pretty brave to say a static assumption would apply in this case.

To implement transient lap time simulation you have to use specialist computer code, as integrating all these equations and performing all these force

balances can't be done in a spreadsheet. The downside is that it will run slower than pseudo-static lap time simulation will, although the ever-increasing power of personal computers means that these simulations can be run at the track on a laptop.

ChassisSim is a case in point, with many of our customers using it during and between sessions. The only way you'll get better than this is to actually run the car on the circuit. Given how limited circuit running is, and what we have just discussed with regards to tyre load variation, this is a critical distinction.

TRANSIENT IN PRACTICE

So what do transient lap time simulations look like in practice? To illustrate this, consider this comparison of actual vs simulated data on an oval, as shown in figure 5, where the actual data is coloured, the simulated black. As you can see, there's not a lot of difference, which is the whole point of the exercise. As with the V8 Supercar case, I've blocked out the scaling due to the fact that this is actual data, but you can see clearly that there are some very noticeable bumps on this circuit. As we discussed in equations (5) and (6) this is where pseudo-static simulation is no longer appropriate. This illustrates that the bumps and transients are going to have nearly as much say on your mid-

corner grip as your wing settings.

What you see in figure 5 illustrates the power of transient simulations because it opens up a much wider world of set-up variables to investigate and vehicle properties you can reverse engineer. For example, using transient simulation you can investigate how damper adjustments are going to impact on lap time. You can also see transiently what the car is doing, so you can zero in on what to adjust. Also, remember every lap time simulation you do in transient simulations such as ChassisSim is the equivalent of running the car on a seven-post rig. This is the power of what you have at your fingertips.

Another consequence of using transient lap time simulation is that it is not ultra-reliant on grip factors. This is a direct consequence of what we discussed using figure 4 and equations (5) and (6). One of the biggest adjustments that users transitioning to ChassisSim have made is the fact that grip factors in ChassisSim are trim tabs, as opposed to absolute necessities. This is because, since we are taking into account bumps and other transient effects, we don't need fudge factors to get the cornering speeds to match up.

CONCLUSION

In closing, not all lap time algorithms are created equal, and it is very important to understand the difference between them. Pseudo-static lap time simulation is a good first step in understanding vehicle behaviour. If you need to get some rough ideas on wings and gears and basic mid-corner car sensitivities, it's a valuable tool.

However, transient lap time simulation provides a far more complete understanding of vehicle behaviour. It will do this because its results are derived from the fundamental equations of motion. You do pay a price, of course, in longer execution time, but it gives you the capability to evaluate so many more vehicle parameters. And this is its strength, for it is the critical edge between winning and losing. After all, that is what our business is all about.



AMARI AEROSPACE LTD

Quality Service Providers of Aerospace Metals

- ALUMINIUM
- STEELS
- TITANIUM
- NICKEL ALLOYS
- BAR
- PLATE
- SHEET
- TUBE
- SAWING
- GUILLOTINING
- ETCHING
- TESTING



For a prompt, courteous and competitive quote, please contact our motorsport sales team on:

Tel: +44 (0)2380 742 750 Fax: +44 (0)2380 741 947

Email: sales@amari-aerospace.com



www.amari-aerospace.com

performance partners



At DC Electronics we don't just design and build wiring looms. We are one of the world's leading providers of complete electrical systems. Whether you require a single engine loom, or a full race championship package, we have the expertise to deliver a bespoke solution to give you the competitive edge.

Coming soon for the 2011 season:

- Three panel electro luminescent lighting kits from a single inverter
- Lightweight electric power assisted steering system
- 4 Channel Power Control module
- Rear vision camera system for closed cockpit race cars
- Electric power steering rack



Our US Distributor

 Palm Coast, Florida
www.kineticracing.com

www.wiringlooms.com
 custom made systems for motorsport



Distributors for: Cosworth / MoTeC / OBR / Race Technology / Braille Battery / Variohm EuroSensor

• WIRING LOOMS • CONTROL PANELS • DATA ACQUISITION • ENGINE MANAGEMENT • ELECTRO LUMINESCENT & LED LIGHTS • POWER STEERING •

How the British Government is going to damage the motorsport industry

Sam Collins dips his toe into politics

I reclined into a seat in the Whitehall boozier, observing my pint of English ale and listening to my friend explain why increasing university fees would not impact his firm. 'You see, we have an excellent apprenticeship system, one of the best there is. So the fees thing really doesn't cause an issue.'

My friend is a senior figure in a major European engineering company and probably has the same attitude that many in the motorsport industry share. Some of them quite probably also detested the student protests (and associated riots) that took place in the UK late last year. But I fear this attitude is wrong. This

one decision could create havoc in all engineering-led industries, including the motorsport sector, which, in the UK alone, employs 40,000 in full-time jobs and turns over £3.6 billion in exports.

So what was it my friend was

it will price the core of our talent out of the best establishments

missing? After all, the facts are fairly clear - English universities can now charge up to £9000 (\$14,500) per year in fees, which is a huge increase on the current cost of attending university in

England, but what does this have to do with engineering?

Well, it's all a question of class. Broadly speaking, engineering students in the UK tend to be middle class, and from middle income families. I've asked around

year I was there, we paid around £1000 a year in fees to study our, BSc, MSc, BEng and MEng courses, making a total cost of about £3000, plus of course the necessary living costs, books etc.

Of course, the politicians will rush forward saying there are grants, bursaries, scholarships, sponsorships and various other hand outs up for grabs, but realistically, the middle class, middle income students will not get a look in.

The new fees do not have to be paid up front, they will be given in the form of loans that have to be paid off at differential rates after graduation, depending on how your career path pans out,

Rockingham boost for youngsters

Rockingham circuit in Northamptonshire, UK, has teamed up with the Enterprise Education Foundation (EEF), to establish the Rockingham Education Partnership, which aims to provide hands-on projects and learning experiences based around the business. The EEF, which is a not-for-profit organisation, will be working with young people aged 11 to 25 across the local area, in order to help develop

transferable business skills. Chief executive of Rockingham, Charlotte Orton, said, 'We have always recognised the key role industries such as motorsport can play in helping to inspire young people to pursue the right choices. The EEF has a wealth of experience working within education and with young people, and therefore we are delighted to have them on board to manage and deliver this area of the Rockingham business.'



Mitsubishi Electric expands deal

The Sauber F1 Team and Mitsubishi Electric have extended and expanded their six-year partnership. Mitsubishi Electric will now become technical partner to the team with immediate effect. In the course of this cooperation, Mitsubishi Electric will continue to equip the Swiss team with die sinking and wire cutting eroding machines.

More recently, it has also been supplying robots for laminating carbon components. The Mitsubishi logo appears on the transporters, press releases

and pit screens. Team principal, Peter Sauber, comments: 'Mitsubishi Electric has been a key partner for the past six years. Mitsubishi Electric has already made an important technological contribution by supplying the team with eroding machines, and this cooperation will now be extended to laminating robots. As far as I'm concerned, it is particularly valuable that this long-standing partnership has stood the test of time even during this period, which has been difficult for us.'

Lola tie up boosts Caterham sales

UK-based sports car manufacturer, Caterham Car's recently launched SP/300.R sports racer has experienced substantial demand, just one month after its launch at the 2011 Autosport Show.

Currently, 14 of the 25 Caterham-Lola SP/300.R racecars planned to be built this year have already been

sold. Caterham Cars managing director, Ansar Ali, said: 'We are delighted with the way the car was received at the Autosport show. It's the first new model Caterham has built for 15 years but, even so, we were bowled over by the reaction and the interest, which led to several deposits for cars being placed almost immediately.'

but that's still a substantial debt to take on board. In some subjects, like history and politics, this will make very little difference, but in engineering it will price the core of our talent out of the best establishments.

What will happen is that the wealthy, public school-educated students who can afford the fees will not be impacted, while the low-income students will (hopefully) be looked after by the aforementioned hand outs. But the middle income, middle class students, the core of British engineering talent, will get nothing. The very people who drive the motorsport industry will no longer have access to the best education, and that will have huge implications. Britain will no longer be able to produce the likes of Tony Purnell, Ben Bowlby, Patrick Head and James Key.

Instead, they will be giving way to graduates from the likes of TU Delft, UNC Charlotte, Tokyo Denki and Tsinghua University,



and the industry will necessarily migrate to those areas.

And it gets worse. While the fees to students are rising way above the odds, the funding from Government to universities is set to be drastically cut, to the point where the University and College Union is suggesting that more than a third of higher education institutions in England will be at risk of closure.

I'm not alone in being concerned about this. The Institute of Mechanical Engineers is too. After the cuts and funding increases were announced, a spokesman at their Westminster headquarters was

moved to comment: 'The UK is facing a number of challenges over the coming decades that require engineering skills for their resolution including, for example, achieving our stringent carbon emissions reduction targets. Furthermore, to move the economy away from its dependence on financial services we must boost exports by reinvigorating manufacturing.'

Engineering is recognised as a strategically important and vulnerable subject and must be treated like medicine. Able students must be encouraged to pursue engineering if we are to avoid a skills shortfall in the near

future. It is vital that the student funding mechanism does nothing to dampen the enthusiasm for engineering as a career...'

When I explained all of this to my friend, he realised the issue was rather more serious than he had at first thought. And it is likely his firm will have words in the right ears, which can only be a good thing in the long term.

I implore anyone reading this to write to the British Government to protest the increase in tuition fees. If you are in the UK, contact your local MP. If you are outside the UK, contact <http://www.ukti.gov.uk/home.html>



Record profits for Porsche AG

The German sports car manufacturer has generated record profits in the short fiscal year from 1 August to 31 December 2010. Sales were 3.867 billion euros, 59 per cent up on the respective prior-year period. The net operating profit was 688 million euros, compared

with 227 million euros from August to December 2009, which equates to tripling the prior-year result and to a return on sales from operations of 17.8 per cent. With a cash flow of 876 million euros, the manufacturer distinctly improved its position in comparison with that of 2009.

VI-SimCenter opens its doors

Simulation specialist VI-grade has announced the opening of a new facility, the VI-SimCenter, which occupies an area of 250m² in Tavagnacco, Udine, Italy and features three driving simulators from the VI-DriveSim product line, representing the culmination of two years of development work.

There are two static simulators with fixed platforms and one dynamic with a moving platform. The moving platform machine is currently the only

prototype of this kind installed worldwide and represents the most recent trends in automotive human-in-the-loop simulation, thanks to its innovative kinematics.

The same top-class simulation engines for graphics and physics are used on all three machines. Both configurations are based on a three-projector system and on a 180-degree screen that leads to unprecedented graphic immersion and resolution.

Prodrive's multi-million carbon contract

UK-based Prodrive has been commissioned to use its composite manufacturing expertise to produce carbon fibre parts for three luxury and sports car manufacturers, the contract reputedly being worth over £10 million. The two manufacturers of luxury cars are using carbon components for the exterior of their cars for the first time, having previously only used carbon for decorative interior trim. These parts will range from door mirrors and bumper inserts to rear diffusers and sill extensions, and all will

be left unpainted, presenting the composite's weave as the finished surface.

For the sports car manufacturer, Prodrive will manufacture a full carbon interior trim, as well as external sub-assemblies. 'These are the largest ever contracts for our composites division, both in terms of volume and value, and mark a significant step by vehicle manufacturers towards the increased use of carbon fibre for exterior applications,' says Prodrive's composites manager, Ian Handscombe.

STRAIGHT TALK

Bernie and Boris should talk



PAUL J WEIGHELL

While consuming my usual breakfast *China Daily* - a newspaper, not a brand of tea - my eye caught the headline 'A Winning Formula' and an article about the Chinese Grand Prix in Shanghai.

The city authorities there admit that race attendance has fallen from 270,000 in 2004 to 155,000 last year, but they have nevertheless contracted with FOM to hold the race for another seven years. 'More fool them, I thought...'

But Shanghai calculates that the local economy has been boosted by \$1.5bn since the first race in 2004. If Bernie charges, say, \$40-50m a year and it costs about the same to stage the race, that still yields a nice \$150m annual earner dropping like warm confetti on the surrounding businesses.

Munching toast, I then compared that halcyon dream with the traditional British approach to the same opportunity. First, we argue over which windswept and inaccessible part of Blighty will hold the race and then we argue over who will lose most money running it. We finally decide to hold a national event with global coverage just where the local towns are small and unknown, at a stroke minimising any benefit from the captive tourism of some of the world's richest individual and corporate racegoers.

As such, the national cash extraction machine that could be the British GP is instead doomed to be as effective as the lukewarm muddy tea served up from converted caravans in the Silverstone fields, and by fields, I do mean 'fields'. It all seems contrary to the point of sulking, and one can see why Bernie is driven to tears of frustration by the UK attitude.

Savouring coffee, I pondered widening our horizons beyond the realms of Silverstone to think instead of the whole of the UK as the Grand Prix's profit centre, to ensure the race provides so much income that it becomes profitable to the business community of the area, even if no one turns up to watch.

Profitable? Well, the Silverstone Recreation Centre does earn a crust from home-

the British GP.

Like Shanghai, London could perhaps squeeze another \$100m a year from the GP, with the additional brand enhancement for UK plc that the delights of the Silverstone village pub are never quite going to match.

Less upsetting to London council taxpayers than the Olympian losses of 2012, London could be a televisual feast for global TV with Big Ben,

Nowhere but London has the proven experience of top-class tourist fleeing

cooked burgers, warm beer and a village hall dance marathon, but where are the city lights, the restaurants, the shows and, very importantly, the iconic visitor sights that will be remembered forever? No offence to Towcester, but it's not there.

Surely, a national and globally covered event has to be held where visitors can be turned upside down and carpet beaten until their last pennies drop out? And nowhere but London has the proven experience of top-class tourist fleeing befitting

Buckingham Palace, the Thames, the Gherkin and the Shard all marketing the UK so much more positively than the wastes of the A43 and the enduring odour of the Battleship Bogs at Becketts corner ever could.

A British GP in London may never rival a Monaco GP, but there is surely no need for us to remain shackled to the tourist disaster that is Silverstone either. Yes, I know there is now a long contract in place, but perhaps Bernie and Boris should talk it over with them. 



A pre-British GP demonstration mid-week in central London in 2004 saw a turnout of half a million people - one or two more than were expected...

BRIEFLY...

Bailey buys BF1

John Bailey has completed a management buyout of engineering specialist, BERU f1 systems. The company will continue to operate from its current facilities in Norfolk, UK, and continue to develop and manufacture products for the automotive, motorsport, defence and aerospace Industries. Bailey will continue at the head of the firm, with the trusted management and engineering teams for the electronics, composites, force measurement, TPMS and wiring divisions remaining unchanged. The company will continue to represent Borg Warner BERU Systems with its TPMS activities and remains focussed on development of its infrared and other TPMS technologies. For continuity, all contact numbers and email addresses will remain the same.

Motorsport unplugged

A global shortage of electrical connectors has hit a significant number of teams. The shortage is thought to be due to suppliers reducing stock levels during the economic downturn. So bad is it, some teams have had to resort to cannibalising old harnesses, whilst others are being forced to miss vital tests and races. Lead times of up to 14 weeks are reportedly widespread.

Expensive fluids

BASF is increasing the sales prices globally for all its coolants, brake fluids and speciality fluids by up to 300 euros (or the equivalent in other currencies) per metric ton. The company says the price adjustments are necessary due to significantly increased raw material costs.

Belgian Shell

Shell has announced a multi-year agreement with the Formula One Group to become the Official Title Sponsor of the Formula 1 Belgian Grand Prix at the Spa

contd...

Introducing the **NEW** Racecar Engineering website

The essential online resource for motorsport technology



- **Breaking News**
- **Technical Analysis**
- **Blogs + Data**

www.racecar-engineering.com



Europe's **largest** dedicated trade-only motorsport exhibition

Thanks to everyone who came along this year

 **AUTOSPORT**
INTERNATIONAL
Engineering Show

In association with **Racecar**
The International Journal of Motorsport Technology
engineering

**12 & 13 JANUARY 2012
NEC BIRMINGHAM UK**

**DON'T FORGET TO PUT
THE DATES IN YOUR DIARY**

WWW.AUTOSPORTINTERNATIONAL.COM/TRADE

THE BUSINESS

Motorsport to automotive



CHRIS AYLETT

The automotive OEMs have daunting low carbon targets and they're looking for help - from the motorsport industry

We are entering the most unpredictable engineering period in the global automotive industry, one that has not been seen for the past 100 years, so said the co-chair of the Automotive Council UK, Richard Parry-Jones, at a recent MIA conference. He emphasised that this unique period is full of opportunities for motorsport companies and encouraged the MIA to launch the 'Motorsport to Automotive' initiative without delay.

The commitment to a low-carbon future in automotive manufacturing is behind his statement. National governments extracted a high price from

OEM and Tier 1 manufacturers to commit to a 'technology road map' for low-carbon vehicles and fuels, following which they must develop a competitive automotive supply chain to deliver these solutions. It is this which opens the door for motorsport companies to find new business.

In simple terms, the OEMs need a new, fast delivery, innovative supply chain in the area of low carbon - and that is made for motorsport. This commitment has been strongly backed by the UK government, which is determined to make Britain a leading centre of low-carbon expertise.

Nissan took the strategic decision to earmark £420m for

of the end solution that adds to the opportunity. The ability of motorsport to change direction and pursue and deliver new solutions is a significant asset that is now relevant, and being sought by OEMs.

The five priority areas identified are all of value to motorsport. These include lightweight vehicle and powertrain structures, internal combustion engines, energy storage and management, and electric machines and power electronics.

Now is the time to bring to the attention of UK OEMs the capabilities of the motorsport industry to help deliver these priorities. Make no mistake, there is substantial funding available for companies that can help mainstream automotive companies meet these challenges.

The MIA has kicked off the Motorsport to Automotive programme by accepting an invitation from Jaguar Land Rover to create an 'exhibition of motorsport capability', which will be located inside the Jaguar R&D Centre at Whitley in May. This will allow hundreds of in-house engineers to meet with, and discuss, the capabilities of MIA members to address these low carbon needs. It is planned that similar exhibitions will be run within OEMs, accelerating their knowledge of the motorsport industry and opening up these opportunities.

I encourage you to learn more about the Automotive Council and engage with this exciting opportunity as part of your diversification plans.

Full details are on the MIA website - www.the-mia.com

BRIEFLY...

Francorchamps circuit and to continue its trackside advertising programme at selected F1 races. The event will now be known as the Shell Belgian Grand Prix. The oil giant will continue its long standing partnership with Ferrari

Facom to supply Citroën

Europe's largest hand tool company, Facom, has been appointed the official tool supplier for Citroën Sport's WRC team. The Facom brand will be displayed on the Citroën DS3 WRCs driven by Sebastien Loeb / Daniel Elena, and Sebastien Ogier / Julien Ingrassia. Facom logos will also be displayed on Citroën's technical support trucks and mechanics' clothing, enhancing the partnership further.

Intercomp rule the roost

Five teams that found their way to the winner's circle during Speed Weeks at Daytona did so while using Intercomp as their preferred chassis set up equipment. Elsewhere, an impressive 38 of the 43 teams that competed in the Daytona 500 used Intercomp scales.

Cometh the hour, cometh the HR man!

Randstad has upgraded its partnership with the AT&T Williams team. Founded in 1960, Randstad is a global leader in the provision of flexible recruitment and HR services. Since the start of its partnership with Williams in 2006, Randstad branding has traditionally been positioned on the cockpit surrounds, but will now also appear on the engine covers and drivers' suits.

K&N no 1 in NASCAR

NASCAR has designated K&N Filters its number one supplier. In a multi-year deal, K&N will maintain its status as an official developmental series partner of NASCAR by continuing its run as title sponsor of the NASCAR K&N Pro Series. It will also remain a NASCAR prize money and decal program sponsor.

OEMs need a new, fast delivery, innovative supply chain - and that is made for motorsport

automotive OEMs in return for recent financial support, and that price is rapid delivery of R and D investments and solutions to meet the CO₂ challenges. The talking has stopped and now the doing is underway.

Support from UK automotive OEMs is particularly significant, as they surround Motorsport Valley, the centre of global motorsport innovation. Stronger linkage with the substantial R and D base of Britain's automotive industry can only be good for the wider world of motorsport.

With a value of 20 billion euros, the automotive sector is Europe's largest investor in R and D. The UK Automotive Council has brought together all the leading

the production of its new Leaf model, including a new battery plant in the UK, which the government supported with over £20m of funding.

OEMs have worked together to define a clear technology strategy where individual manufacturers prioritise certain technologies to fit in with their own brand values, but they all share a common view of the 'road map' they must follow.

It is clear there will be a technology shift to alternative powertrains and transmissions to meet exacting CO₂ targets. This map clarifies how the industry will migrate from hybrids to fuel cell, electric vehicle or plug-in hybrids, and it is this diversity

UNDER DISCUSSION: OPTICAL LIFT

The light fantastic

Refractive object generates stable optical lift

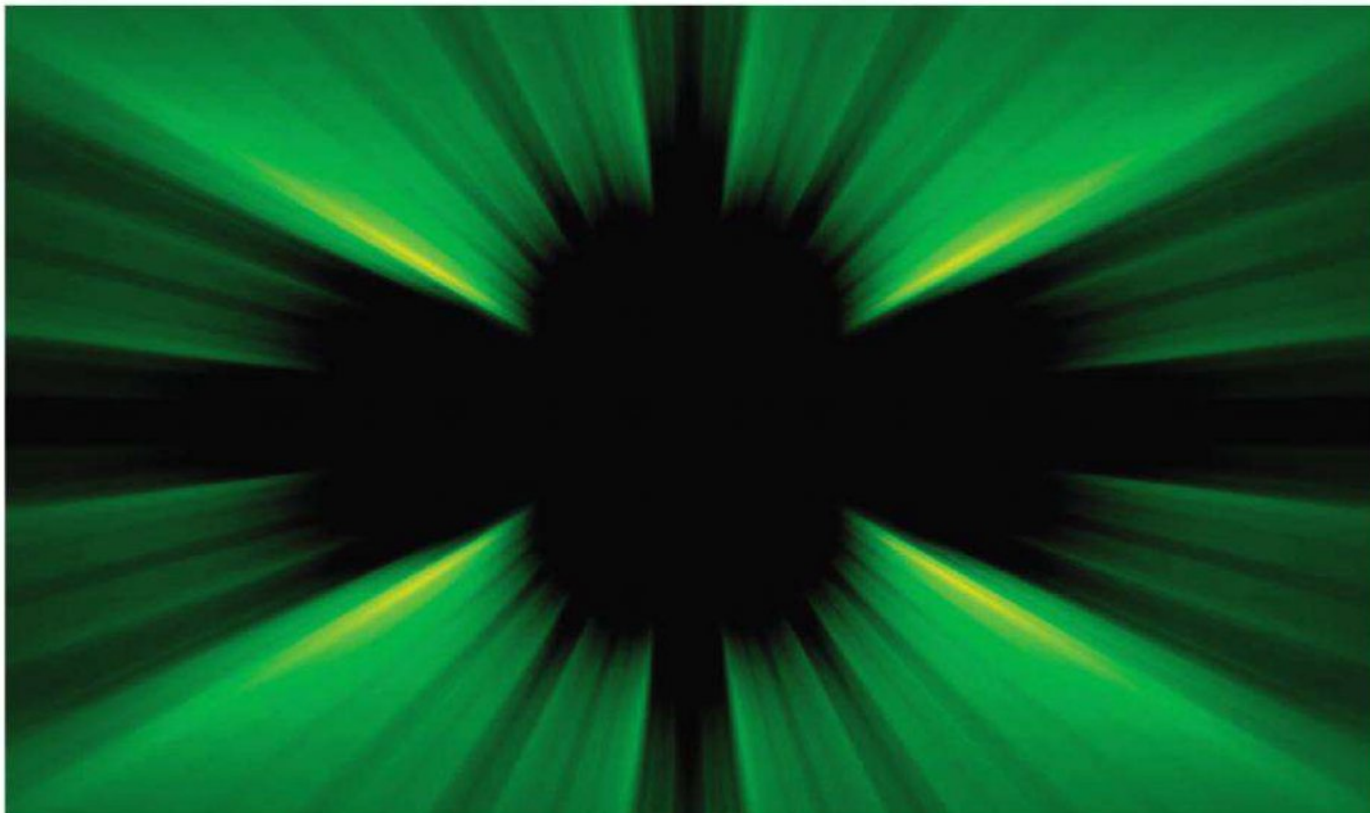

Regarding the “How Wings Work”, I’d like to add this to the discussion on how a curved surface is effected by the stream lines of passing energy.

**Roger Kessing,
PE, ME (Retired, but still racing
FF!), USA**

Rochester Institute of Technology (RIT; Rochester, NY) researchers have mathematically predicted and experimentally observed the optical equivalent of aerodynamic lift. Unlike optical tweezers that require an optical gradient to trap a dielectric particle, say, in the waist of a of a focused laser beam, and translate that particle along the beam transmission axis via scattering forces, the generation of optical lift does not require a gradient. Instead, the RIT researchers explored

the transverse lift of a dielectric object due to uniform illumination with negligible gradient force. The demonstration has future implications for improved interstellar space travel or for applying noncontact forces to microscopic particles using gradient-free optical sail designs.

A BASIS IN THEORY

The Kutta-Joukowski theorem of aerodynamic lift supports the concept of optical lift through reflection and refraction of light over cambered or arc-shaped surfaces called light foils. Using numerical computations of the radiation pressure exerted on arbitrarily shaped objects through ray-tracing techniques and public domain software, the force and torque could be determined as a function of the angle of attack for a uniform light beam. The calculations predict that

10-20% of the incident beam momentum can be converted to a stable lift force for a dielectric rod with a semicircular cross section. To verify optical lift in a laboratory setting, the researchers experimented with microscopic light foils fabricated at RIT’s Semiconductor and Microfabrication Laboratory. The

rods were fabricated by melting rectangular rods of photoresist material on a silicon surface to round the top into an arc through surface tension. Tens of hemicylinders, measuring roughly 6 (base) x 4 (height) x 14 μm (length), were sunk to the bottom of a glass tank filled with water. Collimated laser light at a 975 nm wavelength with a 50 μm beam diameter was directed vertically upward through the bottom of the tank in a z direction.

If you have an issue you want to discuss here, please email the editor at: graham.jones@chelseamagazines.com or write to: the editor, *Racecar Engineering*, Suite 19, 15 Lots Road, Chelsea, London SW10 0QJ, UK. Visit www.racecar-engineering.com

CONFIRMING OPTICAL LIFT

At a 130 mW optical power level, a single rod was rotated to a stable angle as predicted and then underwent lift and levitation. Transverse velocity v_x reached through values of 3.5 $\mu\text{m/s}$ (a maximum when in the region of highest power density for the beam), while velocity was around

Thunderbolt equals lightning?

I thought I would add this to the article on high-powered computing in motorsport.

While it has the potential to revolutionise how we communicate and receive large datasets from cars (or exchange CFD datasets etc), it's all too early to know if it will. It's just about which manufacturers support it.

Thunderbolt is the latest interface for connecting hardware peripherals to computers. Much like the familiar Universal Serial Bus (USB), Thunderbolt originated at Intel in 2009, under the codename of LightPeak. Apple's recent Apple MacBook Pro computers (early 2011) are the first to bring the standard to market with exclusivity guaranteed until 2012.

The Thunderbolt interface is based on two existing standards - PCI Express and DisplayPort. It promises bi-directional transfer of up to 10Gbps (Gigabytes per second) - more than 20x the existing USB 2.0 and twice that of the stillborn USB 3.0. Each port can support daisy chaining of up to seven devices, two of which can be high-resolution displays. It also carries up to 10W of power to connected peripherals. (See table below)

While similar modern interface standards (USB 3.0, FireWire 800, eSATA) have had little impact on the consumer market, Thunderbolt appears to be gaining momentum from

hardware manufacturers that already produce PCI Express devices.

Thunderbolt is in many respects a consolidation technology. It offers a single, high-speed I/O connection that can be extended to complement other technologies without necessarily rendering them obsolete. But for manufacturers producing high-performance hardware devices it is a relatively straightforward answer to the ever-increasing demand for next-generation transfer rates from portable and workstation computers.

Initial impact is expected in the video editing industry where software applications are typically bound by the speed of I/O and by reading large, high-definition video from storage devices. However, with engineering applications now producing and consuming datasets of terabytes in size, the implications of a high-speed yet cost-effective interface is significant, if not a little premature.

Ultimately, Thunderbolt's fate lies in the hands of the PC manufacturers whose adoption could either revolutionise the high-speed peripheral market or confine it to a niche previously occupied by its similarly Apple introduced and once equally promising predecessor, FireWire.

Martin Galpin,
Letchworth Garden City,
Hertfordshire, England

TABLE 1

	USB 2.0	Express Card	USB 3.0	Thunderbolt
Data Transfer Speed	480 Mbps	2.5 Gbps	5 Gbps	10 Gbps

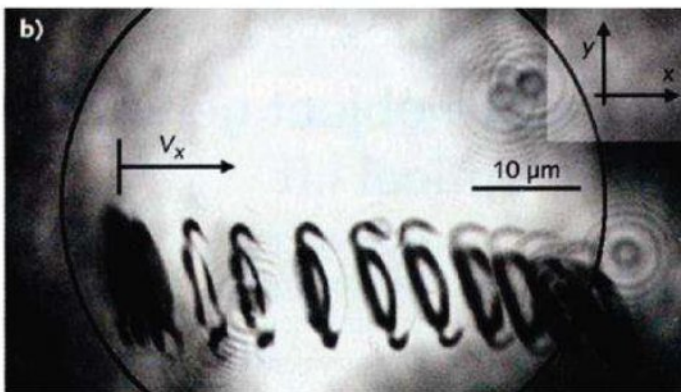
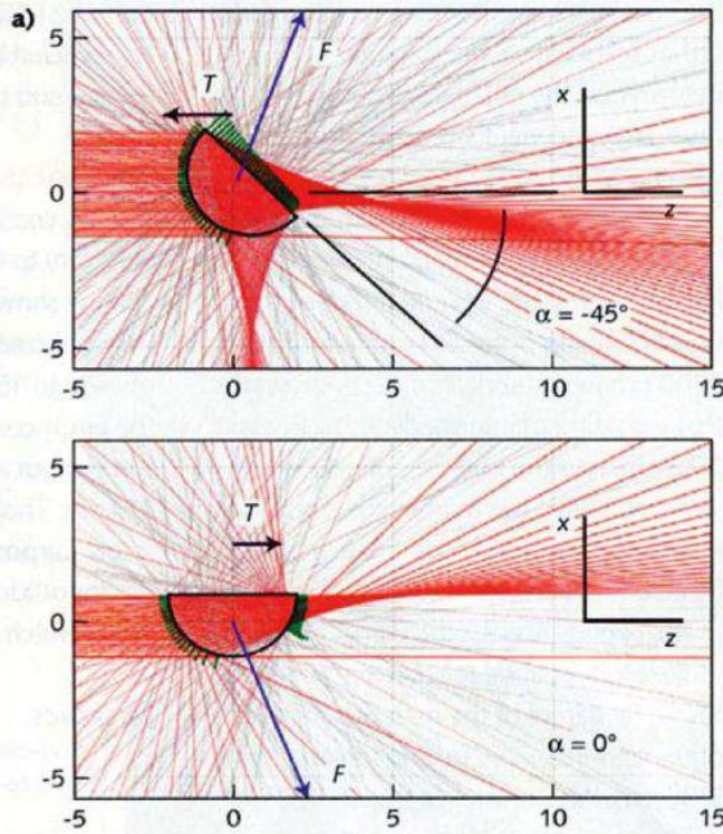

Mathematical modelling shows the force and torque exerted on an arc-shaped glass rod by uniform, nongradient illumination (a). An actual semicylindrical rod immersed in liquid and exposed to a 130mW light source (in the z direction out of the paper or screen) lifts sideways from left to right due to the transverse optical lift force (b). The rod initially experiences torque and then is translated with velocity v_x toward the right. The lift force brings the rod out of focus in the z direction. (Courtesy of Rochester Institute of Technology)

2.5 $\mu\text{m/s}$, resulting in a lift angle of 55°.

The transverse lift force and forward scattering force could be optimized using more uniform semicircular rods.

'This work reminds me of the early days of flight or rocketry, only better: these early systems were plagued with stability difficulties and the Wright Brothers and Robert Goddard spent considerable time learning to overcome catastrophic instabilities,' says RIT associate

professor, Grover A. Swartzlander, Jr. 'Fortunately, the lightfoils we designed are remarkably stable. As we continue to design more complicated special purpose lightfoils, such as for steering solar sails, stability will be a primary concern. We also seek to optimize the lift to mass ratio of the light foil.'

Reprinted from the February 2011 edition of *Laser Focus World* Copyright 2011 by PennWell, written by Gail Overton.

Autotel Digital Race Radio

Motorsports Communications Systems

Complete Range of analogue & digital Race Radio systems for all levels of motorsport.

Show discounts

Dealer Packages

Autotel Race Radio
0044(0)1508 528837

www.raceradio.co.uk



The Difference is Clear



New from Rowley Race Dynamics

3rd Edition

An Introduction To Race Car Engineering Book 1

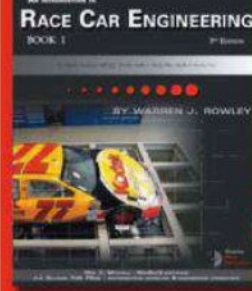

With the help of powerful software packages, this exciting new book provides the race engineer with considerable insight into the possible performance envelopes of a modern race car.



TO ORDER:
www.rowleyrace.com

Wm. C. Mitchell Software - Racing by the Numbers

Introducing version 4.02 of the WinGeo3 Suspension Geometry program with Force-based Roll Centers ----- explained! -----

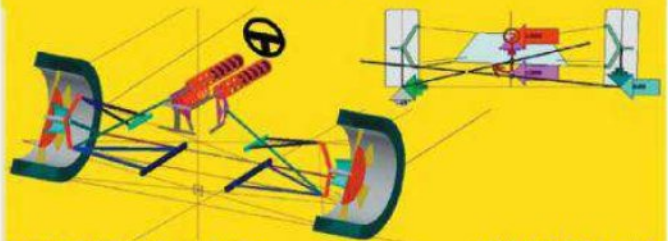

www.MitchellSoftware.com
800-844-7296 from USA and Canada
125 East Plaza Drive, Suite 117

704-660-0330 voice
704-663-0085 fax
Mooresville, NC 28115 USA

CHASE

CHASECAM.CO.UK

CAM

THE NEW CHASECAM ONBOARD DATA MODULE IS HERE...



NEW!
PRODUCT

Your PDR has just got smarter...

The PDR 100 GF solid state digital recorder can now capture both high quality video AND record data!

Using our new **Data Module** and **Dashware** software, any PDR can record data from our 10Hz GPS, onboard accelerometers, vehicle sensors and even OBD2. Analyse raw data and view as graphics on the video. Custom graphic packages also available.

See our new products in action on The Ring video, go to the **ChaseCamTV** channel on YouTube or see our website www.chasecam.co.uk for further details.

www.chasecam.co.uk

Tel : 0333 666 0366 or Email : sales@chasecam.co.uk

MSA / FIA COMPLIANT FUEL SAMPLING KIT FROM THINK AUTOMOTIVE

As of 2009 the MSA states in its Blue Book (page 150 [C(b)] 19) that cars competing in British + MSA titled championships must have a system built in that is capable of taking a fuel sample. Here at Think Automotive we have a variety of kits available to enable you to comply with both MSA and FIA regulations.

Prices start from:
£73.25



CALL US NOW ON:

0208 568 1172

OR VISIT:

www.thinkauto.com

Aeroquip

MOCAL
Fluid Systems

ATL
Tel: 44 (0) 1928 35700

Home Products Company Contact Links Important Info



NEW ATL WEBSITE NOW ON-LINE

Welcome to **ATL**

ATL has celebrated its 10th anniversary and is proud to have been a leading force in the development of the world's most advanced and reliable rally cars. The success of ATL's products is a testament to the quality and reliability of the components that we supply. Our products are used in a wide range of applications, from rally cars to commercial vehicles. We are proud to have a reputation for excellence in the industry and we are committed to providing the highest quality products to our customers.



ATL's engineering excellence and high performance motors and control systems products, ATL services the motors and control systems industry. Explore our website for more information about ATL's many products.

Dunnell Engines

Duratec and Zetec engines and components for road and race

Duratec full race and rally applications

zeturtec
Duratec Engine
2.0-2.5 Litre
200-330 BHP

zetec
Zetec engine
1.6, 1.8 & 2.0 litre
175-270BHP

Knut Ove Borseth -
2009 European Rally Cross Champion
Using our latest Duratec RX series engine



Complete engine & component development

www.dunnellengines.com

Tel: +44 (0)1449 677726 Email: info@dunnellengines.com
Unit 10 Tomo Business Park, Cretinger Rd,
Stowmarket, Suffolk, IP14 5AY, England

MOTORSPORT QUALITY ROD ENDS AND SPHERICAL BEARINGS

INTERNATIONAL STOCKING DISTRIBUTORS
AURORA® · RODOBAL® · Seals-it®



*broadest range in Europe
metric and inch sizes*

contacts in English, Deutsch, Français, Italiano

ACCESSORIES:
side seals
protection boots,
jam-nuts
bearing installation tools

Getecno srl
16141 GENOVA - Italy
fax +39 010 835.66.55
phone +39 010 835.60.16

www.getecno.com - info@getecno.com

SBD Motorsport

Vauxhall, Ford Duratec & Hayabusa
MBE Management systems, kits & components available



MBE9A8
Fuel injection up to 8 cylinders

MBE9A4
Fuel injection up to 4 cylinders

MBE9A4i
Ignition only up to 4 cylinders

Unit 15, Red Lion Business Park, Red Lion Road, Surbiton, Surrey KT6 7QD
Tel: 020 8391 0121. Web: www.sbdev.co.uk. Email: sbdmotorsport@btclick.com

THANK YOU!

On Behalf Of Over 1,000 Exhibiting Companies,
We At PRI Thank The Racing Industry
For A Fantastic 2010 PRI Trade Show!



Steve Lewis
Producer

Performance Racing Industry Trade Show



24TH ANNUAL **Performance Racing Industry** TRADE SHOW

DECEMBER 1-3, 2011 • ORLANDO, FLORIDA • USA

www.performanceracing.com

Russell Eacott

THE INTERVIEW



Q You spent a part of your career at TWR. What was Tom Walkinshaw like to work for?

He was alright actually. There are a lot of horror stories about Tom but, as an employee, it was a really good company to work for. Obviously, it was a big company, so there was a lot of politics, but having said that, I'm still in touch with most of the people I worked with at that time, so it was pretty good. It often looked harsh from the outside, but with Tom, okay, he was an intimidating character, but you were always treated really well within the company.

Q Most of your career has been in Formula 3. What's the attraction?

I just think it's a great formula. The cars are good and, if you've got racecars, then you really want to be running them on the track, and with Formula 3 you can do that, as there's lots of track time and lots of races. And I think it's the best formula you can do as a driver. If you do well in Formula 3, you know you can go to Formula 1, and do well there.

Q Would you change anything about the formula?

I think the FIA has done

a pretty good job. It's a new car next year, and it will have paddle shifts, which is another step in the right direction, but there's not much you want to change. The car is a challenge for the engineers, the drivers and the teams, and you wouldn't want to dumb it down.

You look at a Formula 3 car and think, 'that's a lovely bit of kit'. And you watch them at somewhere like Copse or Becketts at Silverstone and you think, 'Bloody hell, that's quick!' Copse in an F3 car is flat, that's how much downforce the little things have got.

Karun [Chandhok, former HRT F1 driver] drove one for Boyo [Anthony Hieatt, Double R Racing boss] the other week, and he just couldn't believe how much grip it had. In fact, he 'phoned me up and said, 'it's just mind-boggling how much grip this car has got'.

Q What about the size of the budgets in F3?

Everybody says they're too big but, if you look at the mileage that they do, and you work out pound per mile... My drivers will do 10,000km of racing and testing this year. For me, the drivers have got to drive the car. If they're driving, they're

learning, and the team is as well - the engineers, the mechanics, everybody is better at what they do. At the end of the day, it does say 'race team'.

Q Where do you find you're doing most of your development these days?

Everywhere. There's a damper programme, an aero programme and obviously the engine people are doing their bit, too. Our engine supplier, Volkswagen, has also had an aero programme running for years and we get information from that. We've got new engine covers, we have new wing mirrors, and lots of things like that. That all comes from being tied in with VW, and they're a massive help. But we are not a works team, we are part of the VW family.

Russell Eacott, team principal, T-Sport

- **1983:** mechanic at Madgwick Motorsport, Formula Ford
- **1984-'85:** mechanic for Finnish Reynard importer, FF1600, FF2000
- **1986:** Madgwick, British F3, mechanic
- **1987-'91:** Madgwick, F3000
- **1991-'95:** race engineer, Fortec, Formula Renault, F3
- **1995-'96:** race engineer, TWR Junior F3 team
- **1997-'99:** team manager, Portman, F3, F3000
- **2000:** race engineer, Fortec, Kolles, F3
- **2001-present:** set up T-Sport to compete in British F3

RACE MOVES

Sam Heard is to be the new general manager of communications for V8 Supercars, Australia's premier motor racing series. Heard has previously worked at broadcaster Network 10 and, until recently, was based in Los Angeles.

Simon Fuller's XIX Management team is to look after the career of Lewis Hamilton. The McLaren driver, World Champion in 2008, joins the likes of David Beckham and Andy Murray on Fuller's books. Up until the end of 2009, Hamilton was managed by his father, Anthony, but was not represented by a manager in 2010.

Pirelli's motorsport boss, **Paul Hembery**, has been made a trustee of the Richard Burns Foundation. The charity, which was set up to honour the memory of 2001



WRC champion Burns, is aiming to create a specialised Brain Centre, in conjunction with the Brain and Spine Foundation. Burns, whose career was ended abruptly after he was diagnosed with a brain tumour, died in 2005.

Pedro de la Rosa has returned to McLaren as its test and reserve driver - a position he previously held from 2003 until the end

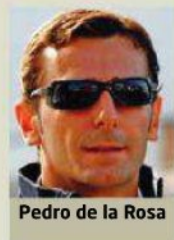

of 2009. Last year de la Rosa raced for Sauber before being dropped mid-season, after which he was signed up by Pirelli to help the tyre company develop its 2011 F1 race rubber.

Australian V8 Supercar engine builder, **Roger Higgins**, for several years the in-house motor man at Dick Johnson Racing, has set up his own InnoV8 Race Engines business with business partner **Steve Amos**. The pair had worked together at DJR for the past five years, while Higgins worked in F1 for 13 years before returning to Australia and V8 competition in 2004.

Danica Patrick has hired veteran NASCAR driver, **Johnny**



Benson, to act as a mentor during some

SPECIAL SUBSCRIPTION OFFER

**ONLY
£60**
per year
**USUALLY
£72**

Save £12 every year

- Save £12 every year
- £1 per issue off the usual rate
- Free delivery to your door

SUBSCRIBE NOW

By phone: +44 (0)1858 438443 quoting P105

Online: www.subscription.co.uk/racecar/P105

By post: Racecar Engineering, Tower House,
Sovereign Park, Market Harborough, LE16 9EF, UK

YES, I would like to subscribe to Racecar Engineering

1 year UK £60 USA \$120 Rest of World £72
2 year UK £110 USA \$225 Rest of World £130

Your name _____
Address _____
Postcode _____
Email _____
Telephone _____

PAYMENT METHOD

Direct Debit: (Available UK only)

Please fill in the whole form using a ballpoint pen and send to:
Racecar Engineering, Tower House, Sovereign Park, Market Harborough LE16 9EF, UK
Name and full postal address of your Bank or Building Society

To the Manager _____ Bank/Building Society _____
Address _____
Postcode _____

Name(s) of Account Holder(s) _____ Bank sort code _____ Originator's Identification Number
Bank/Building Society account number _____ 5 5 8 5 7 6
Reference (for office use only) _____

Instruction to your bank or building Society:
Please pay The Cheques Magazine Company Ltd, Direct Debits from the account detailed in this instruction subject to the safeguards assumed by the Direct Debit Guarantee. I understand that this instruction may stay with The Cheques Magazine Company Ltd and, if so, debit will be passed electronically to my bank/building society.

Signature _____ Date _____

You may cancel your subscription order at any time. Unless you cancel, your subscription will continue automatically at the special rate of just £60.00 per 12 issues - saving £12.00 off the usual subscription rate.

Cheque: payable to Racecar Engineering for £ _____
 Credit Card: Mastercard/Visa/Delta/Maestro the sum of £ _____

Card no. _____ Expiry date _____ / Start date _____ /
Maestro only: Issue no. _____

Signature _____ Date _____



Racecar Engineering
magazine subscription rate for 1 year (12 issues)

UK	£60 (usually £72)
USA	\$120 (usually \$135)
Rest of World	£72 (usually £84)
Rate for 2 year subscriptions (24 issues)	
UK	£110 (usually £144)
USA	\$225 (usually \$270)
Rest of World	£130 (usually £168)

The International Journal of Motorsport Technology
**Racecar
engineering™**

RACE MOVES

of her Stock Car appearances this year. The IndyCar driver is taking in a limited NASCAR Nationwide programme this season, as she did in 2010.

This year's Bristol Motor Speedway race, known for nearly 20 years as the Food City 500, in deference to its sponsors, was named after **Jeff Byrd**, the president of the Bristol track who died in the autumn after a long battle with brain cancer. The name change is for one year only and was suggested by the sponsor.

Trevor Foster, a former Jordan managing director and Lotus race director in Formula 1, has joined the United Autosports GT team as a race engineer. Foster ran Zytek Motorsport until the end of last year. **Ray Mallock**, boss of LMP, WTCC and BTCC outfit RML, plans to race one of the 1960s-vintage Mallock U2 Formula Junior cars that were built by his father, Major Arthur Mallock, at some point this season.

Sadie Wigglesworth has joined the Force India Formula 1 team as its head of sponsorship acquisition and media. She joins the team from Aston Martin Racing, while she has also worked for the Vintage and Sports

Car Club and within the Subaru WRC team at Prodrive.

Dean Shaut, a crewman for NASCAR team Rick Ware Racing, was killed in a road car accident in Thomasville, North Carolina in March. **Stephen Masch**, another RWR crew member, was seriously injured in the same accident. Both Shaut and Masch started with RWR this year as independent contractors on the organisation's Nationwide and Truck teams. Shaut had been involved in NASCAR for 20 years and had worked for organisations such as Hendrick Motorsports and Evernham Motorsports, amongst other teams.



Ron Dennis

McLaren Group boss, **Ron Dennis**, has been banned from driving for six months after going through a red traffic light in Surrey. Dennis, who relinquished direct control of McLaren's F1 team to oversee the company's MP4-12C road car project in 2009, received three penalty points for the offence, which took his total to 12, the point at which a licence is lost

Russell Eacott

THE INTERVIEW

CONTINUED

Anybody who runs Volkswagen engines has access to that database. We switched to Volkswagen about two years ago and they are very good people, I cannot praise them enough.

Q Who are the key staff members at T-Sport?

The chef! No, seriously, I would say my business partner, Alan 'Skelly' Woodhead, who does the engineering, is vital. Without Skelly we wouldn't be here. He does the engineering and I do the business, and that's how we keep going.

When we started, there were six of us, and I engineered a car. But then we had six people and now we have 15, and if one of you isn't in control of running the business and the logistics side of it, then that all falls apart. So you need someone

to do that, and then you need someone to look after the engineering and the technical side of the team. But we have an understanding of what we are both doing, so that keeps it all on the straight and narrow.

Much depends on the racing itself, though, and we will always respond to any changes.

Q What's the future for T-Sport?

It just depends on what's there, to be honest with you. But we're not going to do GP2, because most of the GP2 teams these days are backed by wealthy individuals. There are very few entrepreneurial owners any more. But Formula 3 is professional enough and we can still make it work from a business point of view.

Next month in

The International Journal of Motorsport Technology

Racecar engineering™

On sale
May 13



• LE MANS 2011

Plus:

F1 Brakes, Citroen DS3 WRC, new products, grand prix update, alternative fuels

TWO GREAT WAYS TO SUBSCRIBE & SAVE

You now have the option of enjoying Racecar Engineering as either a magazine posted direct to your home, or by downloading to your desktop computer, laptop or iPad.

Whichever format you choose, every issue is packed with all the in-depth features, interviews and analysis you would expect from motorsport's leading technology journal.



Subscribe to the magazine

- ✓ Twelve month subscription for as little as £42
- ✓ Never miss an issue of the print magazine
- ✓ **SAVE** more than £30 off the regular annual rate

Subscribe to the digital edition

- ✓ Twelve issues for just £34.59 saving 47% off the newsagent's price
- ✓ Instant delivery to your home or workplace
- ✓ Adjustable font-size for easy viewing

NEW

powered by 

To subscribe to either option and to sample the new digital edition visit:

www.Racecar-Engineering.com/P105

Or Call: 0044 1858 438 443

RACE MOVES

in the UK. He already had nine points for three separate speeding offences.

Gary Cogswell has replaced **Dave Fuge sr** as the crew chief on the TriStar Motorsports-run NASCAR Nationwide car, which is driven by **Mike Bliss**.

NASCAR has relaxed its garage area dress code, and the trousers and sleeved shirts-only policy is no more – the governing body now allowing those wearing shorts, sandals, sleeveless blouses, skirts and dresses into the garage area.

Mike Dillon, the vice president of competition at Richard Childress Racing, has been treated for a blood clot in his lung. The team reported that Dillon was hospitalised last week when the clot was discovered. He has undergone tests and was released from hospital to await results. NASCAR driver, Brian Vickers, missed most of last season when blood clots were discovered in his legs and lungs.

One time NASCAR team boss, **Ray Evernham**, is suing

his former co-owner, George Gillett, for US\$19m. Evernham says he is owed the money he put into the team before it was subsumed into the new Richard



Ray Evernham

Petty Motorsports organisation in 2009.

Well-known Formula 750 constructor **Trevor Hegarty** is building a new car for the low-cost category. Hegarty, whose Centaur cars were successful in the 1960s and '70s, will build the all-new car with fellow race engineering veterans **Jim Taylor** and **Dave Elliott**. The car will be called a JDT.

Nick Fry has been appointed a UK Business Ambassador, briefing ministers, ambassadors and UKTI on Britain's motorsport industry. Fry was appointed alongside 32 other Ambassadors, including Sir Anthony Bamford of JCB and Lord Digby Jones of HSBC / Triumph.

■ **Moving to a great new job in motorsport and want the world to know about it? Or has your motorsport company recently taken on an exciting new prospect? Then send an email with all the relevant information to Mike Breslin at bresmedia@hotmail.com**

STRAIGHT TALK

Flexibility is key

Lateral thinking is needed in hard times



ROGER B PHILLIPS

While motorsport is afflicted, like virtually everything else in life at the moment, with global political and economic turbulence, it has become essential for everyone involved to show patience, flexibility and fortitude – qualities that don't always come naturally within our environment. I have often witnessed impatience and dangerous disinterest within the motor racing community in life and world affairs beyond the sport. This may be because success emanates from such palpable single-mindedness. But these things can no longer be ignored.

With recent events in Bahrain, the FIA and the powers-that-be in Formula One were faced with a moral, social and political dilemma, which they didn't seem to handle particularly well. This was mainly because of the financial implications to CVC and FOM if anyone other than the Bahraini authorities took the decision to cancel the race. As Formula 1 ventures into ever-increasing numbers of government-backed events in new locations, these issues might potentially become more prevalent, bringing greater uncertainty to the whole scene. The sport has almost entirely managed to avoid getting embroiled in the politics of nations during the 61 seasons of the post-war World Championship era. The question is, though, can that continue?

This makes it even more significant that Formula One is returning to the United States next year with the Grand Prix in Austin. There is room for more races in the US, but at least this is a start to bringing the F1 World Championship back to a market that is important for so many of the sport's participants and backers. Steve Sexton is the newly appointed president of the United States Grand Prix in Austin. He comments: 'This project represents a unique opportunity for the City of Austin and the State of Texas to be the focal point for a worldwide audience... to [build a] showcase that attracts international visitors and opens new education,

innovation and research opportunities to benefit the global community.'

This is doubtless the hope and aspiration of every new Grand Prix promoter, but an increasing number of far-flung races could diminish the local economic and trade impact of individual events. If you have an F1 event at home, why travel to another country?

Flexibility of outlook is certainly now the key for motorsport folk to find and secure employment. The transferability of skills from motorsport to related sectors and areas of activity is now the name of the game if people seek employment continuity – performance engineering in its widest sense, the aerospace, defence, environmental technology, marine and medical equipment sectors all benefit from people with high-tech skills honed in motorsport environments these days. With jobs now diminishing within motorsport itself, it is time for those who crave career continuity to spread their wings and explore just how their skills can be applied and developed elsewhere.

As far as drivers are concerned, old-fashioned 'sponsorship' is no longer on the radar and those who need financial support in order to compete have to look to more sophisticated strategic partnerships. It is necessary to understand what 'added value' might be brought to a corporation, patron, community or educational institution. There is money around, but the process of securing it is sophisticated and needs a real understanding of how businesses and entrepreneurs work and what they expect from a commercial partner.

The future lies in being inquisitive about the world, noting where the opportunities are and going for them.

Action Resources Ltd. is a motorsport management consultancy specialising in HR, UK employment law, recruitment and driver management +44 (0) 1458 253 442 www.motor-sport.uk.com rogerphillips@actionresources.uk.com

PIT CREW

Editor

Graham Jones

Deputy Editor

Sam Collins

News Editor

Mike Breslin

Design

Dave Oswald

Chief Sub Editor

Mike Pye

Staff Writer

Lawrence Butcher

Contributing Editors

Paul Van Valkenburgh

Technical Consultant

Peter Wright

Contributors

Chris Aylett, Andy Brown, George Bolt Jr, Alan Lis, Simon McBeath, Wouter Melissen, Danny Nowlan, Mark Ortiz, Roger B Phillips, Jef Richards, Martin Sharp, Ian Wagstaff, Paul J Weighell

Photography

LAT, Gavin D Ireland, Pete Lyons

Group Sales Director

Steve Ross

Tel +44 (0) 20 7349 3161

Email steve.ross@chelseamagazines.com

Head of Business

Development Tony Tobias

Tel +44 (0) 20 7349 3176

Email tony.tobias@chelseamagazines.com

Senior Ad Sales Executive

Lauren Mills

Tel +44 (0) 20 7349 3186

Email lauren.mills@chelseamagazines.com

Publisher

Luke Bilton

Senior Publisher

Sarah Arthur

Managing Director

Paul Dobson

Editorial

Racecar Engineering, Chelsea

Magazine Company,

Suite 19 Chelsea Wharf,

15 Lots Road,

London SW10 0QJ UK

Tel +44 (0) 20 7349 1920

Advertising

Racecar Engineering, Chelsea

Magazine Company,

26-30 Old Church Street,

Chelsea, London SW3 5BY UK

Tel +44 (0) 20 7349 3150

Fax +44 (0) 20 7349 3160

Worldwide Subscriptions

CDS, Tower House, Sovereign Park,

Market Harborough,

Leics LE16 9EF UK

Tel +44 (0)1858 438749

Fax: +44 (0) 1858 434958

Subscription Rates

UK £72 (12 issues)

USA \$135 (12 issues)

ROW £84 (12 issues)

News Distribution

COMAG, Tavistock Road, West

Drayton, Middx UB7 7QE

Printed by

Wyndeham Heron

Printed in England

ISSN No 0961-1096

USPS No 007-969

www.racecar-engineering.com

LATE APEX

That's entertainment?

During the course of an interview with *Racecar Engineering*, former FIA technical consultant, Tony Purnell, spoke of the strategy of developing a number of 'levers' that representatives of motorsport's governing body could 'pull' in the course of a Formula 1 race in order to ensure the competition remained close and overtaking opportunities increased.

Various non-interventionist approaches have been adopted over the last few seasons to try and accomplish this aim, with the radically different wing package introduced for the 2009 season being perhaps the most significant, though it is not yet clear whether it has succeeded in spicing up the show to the desired degree.

Similarly, KERS was also introduced that year, billed as a sort of environmentally friendly, road car-relevant, 'push-to-pass' technology. Unfortunately, system weight, development costs and other issues meant it was not universally adopted and, by general agreement of the FOTA membership, was not used at all last season.

For 2011, we have - for want of a better term - an 'entertainment' package consisting of the return of KERS, less durable tyre compounds and the introduction of an adjustable rear wing slot gap intended to assist overtaking. The rulemakers clearly hope the changes will increase the on-track action and make race outcomes less predictable, perceiving this to be what Formula 1's audience wants.

Personally, I think the continual annual tinkering with the rules in the name of improving the show is both expensive and belies an unclear vision on the part of the rulemakers.

It all went a step too far recently, however, when Bernie Ecclestone came out with a suggestion that circuits might consider artificially soaking the track surface at some point during a grand prix in order to inject a further element of unpredictability and excitement into the event. Even more amazingly, a senior representative of Pirelli appeared to agree with

the idea. It is always difficult to judge whether Mr E is being serious when he comes out with such comments, or is simply looking for a reaction from teams and the fans. If he is serious, however, it is simply a step too far. It is pure interventionism, in my view, and has no place in any serious sporting event.

Much more sensible is the recent announcement from the FIA that its circuit commission is to examine whether Formula 1 tracks can be physically changed to facilitate more overtaking - apparently brought about by the frustration of the organisation's president, Jean Todt, at seeing Fernando Alonso's 2010 World Championship bid thwarted by being bottled up behind Renault no 2 driver, Vitaly Petrov, at the Yas Marina circuit in Abu Dhabi. It will take time, and significant

investment on the part of the circuit owners / race organisers, but a good body of evidence suggests this is where the real problem lies.

Interestingly, the Yas Marina circuit is one of

the newest on the World Championship schedule and therefore, one might have hoped, would have benefited from the latest thinking on track design. There is no doubt it is also one of the most spectacular, as it winds its way around the futuristic-looking hotel that forms the centrepiece of the facility, and past the marina with its pristine white yachts. But perhaps therein lays the problem - an architectural *tour de force* it may be, but good motor racing requires cleverly designed circuits first and foremost, not vanity venues that look great on television.

**EDITOR**

Graham Jones

“ it is pure interventionism and has no place in any serious sporting event ”

For subscription queries or to buy *Racecar Engineering*, go to
<http://www.subscription.co.uk/racecar/> or racecarengineering@subscription.co.uk
 telephone 0844 243 0778 +44 1858 438443 (overseas)

• *Racecar Engineering*, incorporating *Cars & Car Conversations* and *Rallysport*, is published 12 times per annum and is available on subscription. Although due care has been taken to ensure that the content of this publication is accurate and up-to-date, the publisher can accept no liability for errors and omissions. Unless otherwise stated, this publication has not tested products or services that are described herein, and their inclusion does not imply any form of endorsement. By accepting advertisements in this publication, the publisher does not warrant their accuracy, nor accept responsibility for their contents. The publisher welcomes unsolicited manuscripts and illustrations but can accept no liability for their safe return. © 2011 Chelsea Magazine Company. All rights reserved.

• Reproduction (in whole or in part) of any text, photograph or illustration contained in this publication without the written permission of the publisher is strictly prohibited. *Racecar Engineering* (USPS 007-969) is published 12 times per year by Chelsea Magazine Company in England.

Made for winners!



inoxline



- Coilovers in 3 dampening variants
- Max. technical lowering
- With german TÜV-certificate



- Optimum performance on the race track
- With adjustable top mounts
- For the race track and the road



- Motorsport suspension for top-level motorsport
- 2- and 3-way adjustable
- Numerous motorsport successes



KW automotive GmbH
Phone: +49 7971 9630-0
www.KWsuspensions.de



KW automotive North America, Inc.
Phone: +1 888 721 3886
www.KWsuspensions.com



KW automotive UK Ltd
Phone: +44 870 990 7536
www.KWautomotive.co.uk

WINNER OF 2011
MOST INNOVATIVE
NEW MOTORSPORTS PRODUCT
OF THE YEAR AWARD AT THE
WORLD MOTORSPORTS SYMPOSIUM



ITS NO SECRET THE GERMANS
HAVE SOMETHING WE ENVY...
(Nürburgring)

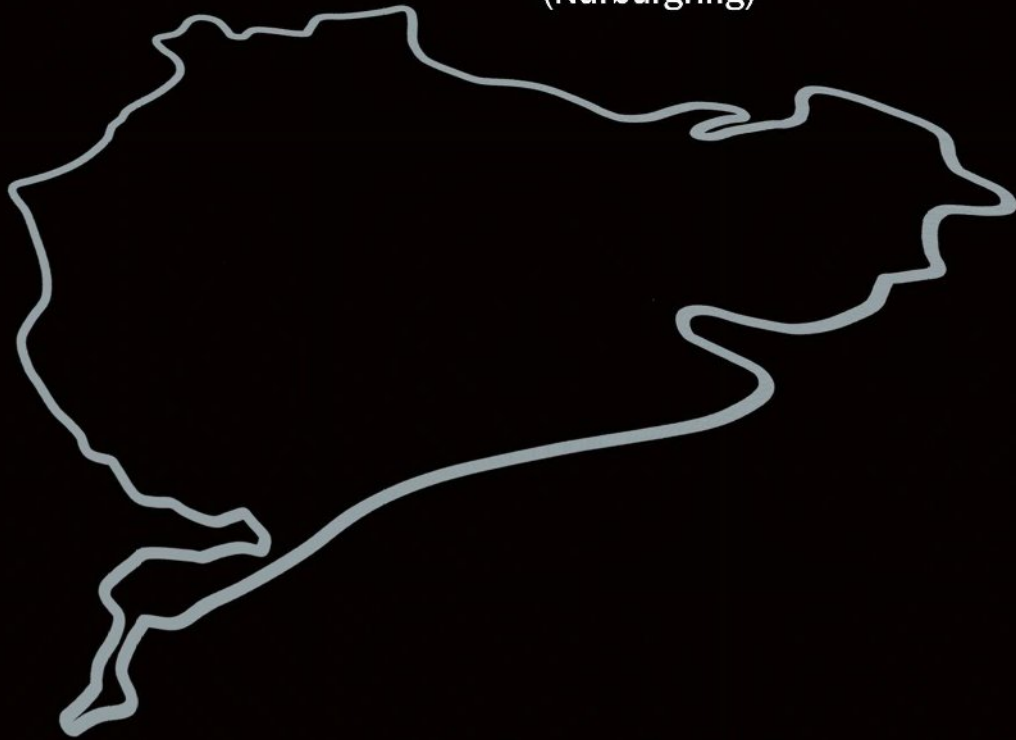

CONSIDER US EVEN.



PERFORMANCE[®]
FRICION
BRAKES

USA 866.392.9936
www.performancefriction.com
motorsportsteam@performancefriction.com

 **R43 ZERO DRAG**
Caliper System

Custom Brake Kits starting at \$1995