

Leading-Edge Motorsport Technology Since 1990

# Racecar engineering™

June 2011 • Vol21 No6 • www.racecar-engineering.com • UK £5.50 • US \$12.50

## MR VERSATILITY - MIKE PILBEAM

Prolific designer recalls his amazing career

## COOLING SYSTEM OPTIMISATION

Maximum radiator efficiency with minimum drag

## FUELS OF THE FUTURE

What will power motorsport in the years to come?

# Le Mans 24 Hours FERRARI F458 GT

Inside Maranello's latest long-distance contender



## Honda's new sports prototype

Full story behind the Acura ARX01e and LMP2 V6



## Penske active suspension

The untold story of a groundbreaking project



## Roadgoing grand touring car

Panoz aims to upset the order with Abruzzi GTE





# Our In-Line Filters Just Got Even Better. New Components. More Versatility.

## Modular In-Line Filters...Now Stackable!

Combine different filter elements into one stacked body for staged filtration that's unbeatable. Larger debris is filtered out in the first stage with a larger micron rated element. A finer micron element in the final stage finishes the job without congestion. A SMART DESIGN.



All filter bodies are 2.47" diameter.

Sizes -6 through -20. Available with either AN end fittings or our HC Clamshell Quick Disconnect end fittings.



New stacking adapters with differential pressure take-off ports attach to pressure gauges and measure pressure drop, letting you know when to change the element. Available with or without end cap.



Stacking adapters without differential pressure take-off ports available too.



NEW short filter body is 3" shorter than standard body. Uses the same mounting brackets and end cap configurations, either AN or HC. Also available without logo/graphics. A GREAT SPACE SAVER.



Pleated stainless steel elements in 45, 60, 75 or 100 micron screens. Optional 15 psi relief valve to override obstructions.



7100 SERIES CONFIGURATION Shown above with our HC quick-release clamshell ends and optional -10 female accessory port on the inlet side to accommodate temperature probes, specialty adapters, etc. GET CREATIVE.

Still More Options



7200 SERIES CONFIGURATION allows you to uncouple the filter body and drop in a new element in seconds.

## Get the ConneXion.™

## Space Saver Fuel Filters With Suction Strainers



Threaded body with "AN" inlet to metric end outlet. 120 mesh suction strainer included. Sizes -4 thru -10. For alcohol or gas. Also available with clamshell body and "AN" ends or clamshell body and clamshell ends.

#120 Mesh Screen Suction Strainer. Other micron elements available.



Threaded body with "AN" inlet and "AN" outlet. 120 mesh suction strainer included. Sizes -4 thru -10. Viton or EPR O-Rings included for alcohol or gas.

Space Saver Suction Strainer's metric outlet attaches directly to fuel pump with female metric threaded inlet ports. Excellent pump protection without restricting flow. Staged finer filtration on the pressure side of the pump is recommended to prevent cavitation, etc.



All space saver filter bodies are 1.115" diameter

Manufactured in the U.S.A.  
from quality domestic alloys.

Go to [www.xrp.com](http://www.xrp.com)  
for catalog downloads  
& new products

# XRP®

THE XTREME IN RACECAR PLUMBING

UNITED STATES XRP, Inc. sales@xrp.com tel 562 861 4765 fax 562 861 5503

EUROPE James Lister & Sons motorsport@lister.co.uk tel 44 (0) 121 525 5800 fax 44 (0) 121 553 5951





**T**his month, Racecar Engineering marks the start of its build-up to the 2011 Le Mans 24-Hour race, which will culminate with the July issue. A new Ferrari is always newsworthy, and the latest F458 GT is no exception. Already, early on-track performances suggest it will be a fitting successor to the previous, highly competitive F430. We bring you the full story behind its development.

Continuing the endurance racing theme, we also have features on the Honda Performance Developments ARX-01e LMP1 car, as well as HPD's LMP2 engine and the Panoz Abruzzi GT contender.

By way of a little variety, we have an interview with Mike Pilbeam, one of the most versatile, prolific and successful designers in the motorsport business, plus the story of Penske's top secret, never raced, active suspension system. In short, it's another busy issue.

It is also a significant one personally, as after nearly three years in the editor's chair, I am stepping down and handing over to my successor, Andrew Cotton. He brings with him a wealth of knowledge and will, I am sure, be an excellent editor of Racecar Engineering.

It only remains for me to thank the magazine's editorial and advertising staffs, our intrepid band of contributors, with whom it has been a pleasure to work and from whom I have learned a great deal, as well as you, the readers. Your enthusiasm, and indeed passion, for the subject of motorsport technology tells me Racecar Engineering continues to have a bright future ahead of it.

#### EDITOR

Graham Jones

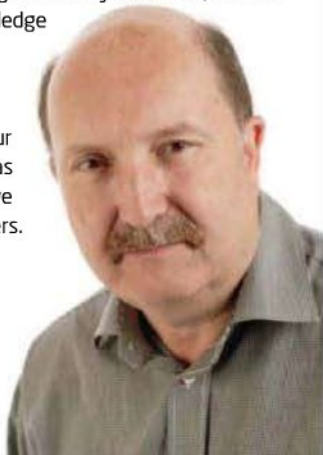

For more technical news and content go to  
[www.racecar-engineering.com](http://www.racecar-engineering.com)



**10 COVER STORY**  
 Ferrari's new GT offering in full



**62 WORLD RALLY CARS**  
 This month, the new Citroën C4 and the BMW / Prodrive MINI Countryman



**48 PROJECT 8800**  
 The amazing story of Penske's secret active suspension system

# Racecar engineering™

The International Journal of Motorsport Technology

## NEWS

- 4 News** New Aston GT, new Nissan electric and the upshot of the new Pirelli F1 tyres

## RACE PEOPLE

- 93 People** Simon Perkins of Willans interviewed, while something keeps our Sam silent
- 98 Late Apex** Improving the F1 show - haven't we heard this one before?

## ENGINEERING SOLUTIONS

- 10 Ferrari F458 GT2** At last, a replacement for the ageing F430
- 30 HPD LMP** Lessons learnt from Prototypes to try and beat the diesels on a modest budget
- 45 Panoz Abruzzi** The latest GTE creation from one of America's more unusual car makers
- 62 WRC** We continue our profile of the new breed of WRC cars from Citroën and MINI
- 72 Brakes** Three different solutions to stopping a Formula One car

## FIRST PRINCIPLES

- 19 Aerobytes** How flip ups over the rear wheels affect frontal downforce
- 23 Consultant** Getting the correct camber settings is a crucial part of set up.
- 27 Databytes** A look at how remote data stations play their part in running a car
- 79 Danny Nowlan** Saving you set up time before you event get to the track

## DESIGN AND INNOVATION

- 39 Mike Pilbeam** More than just a hill climb race car designer
- 48 Penske Active** Penske's never-raced hydro mechanical active suspension system
- 59 Cooling** Keeping cool under pressure
- 70 Fuels** The great question posed - what will power the racecars in future?

## INDUSTRY

- 84 Industry news** Capricorn expands and the UK government invests in technology
- 89 Technical Forum** More of your opinion on the way Formula 1 should be run

Subscribe to *Racecar Engineering* - find the best offers online  
[www.racecar-engineering.com](http://www.racecar-engineering.com)

## FORMULA 1

# Fast-wearing Pirelli tyres light up Formula 1

Nature of races changes as strategy calls dominate

**New Formula 1** tyre supplier, Pirelli, has turned the sport on its head with its new rubber. The tyre manufacturer's brief from the FIA was to design a tyre that degraded faster than the Bridgestone tyres used up until last year, and while there were some question over whether it had achieved this after the opening Australian Grand Prix, the following races at Malaysia and China were pit stop-filled thrillers.

Speaking after the Chinese GP, Pirelli's motorport director, Paul Hembury, said: 'The races just seem to keep on getting better this year. I think nobody watching really knew how it was going to finish until the very end, which is exactly what we wanted to achieve. We saw an interesting split of strategies, with McLaren managing to make three stops

work for Hamilton but Red Bull coming very close to winning with just two.'

Formula 1 tech directors have also come out in favour of the new tyres, McLaren's Paddy Lowe saying: 'I think it is really exciting as we have got

“ a great spectacle... and a job for us to manage it well ”

Paddy Lowe, McLaren technical director

a formula now where it seems to be panning out that tyre wear is critical. I think what is particularly interesting - and a big challenge for us on the pit wall side - is you have to manage the tyres across qualifying and the race. If you were doing four stops you have used five out of

six [sets of] tyres, and how you use those tyres in qualifying has a big consequence on your race result, which we saw to Lewis's [Hamilton] cost in Malaysia. Crucial phases of the race where he lost out were a consequence of tyre consumption that he had

done in qualifying. So a great spectacle I think, and a job for us to manage it well.'

Lowe added that tyre wear has also meant cars have run at a different pace throughout the race: 'I think most of the pace differences you see are as a result of the state of the

tyre at that instant. Every lap you run, the tyre is going off and sometimes at higher rates than others, and different with different drivers. If you have done three laps on a tyre in qualifying, when you hit the track with it in a race you are already set back that amount. If another guy has come out on a new tyre then he is ahead of you, so I think there are phases in a race where you are quicker or slower than the people you are racing but it can come back to you depending on your tyre choices. That means the race result isn't really known until the very end as we have been seeing.'

Beyond the new tyres, other initiatives added to spice up the show include the new moveable rear wing and the re-introduction of KERS, both of which have been successful to varying degrees.

## GT RACING

## Vantage to replace DBRS9

Aston Martin Racing is to produce an all-new racecar based on its V12 Vantage model for GT3 competition from next year.

The Vantage GT3 will replace the DBRS9, which was launched six years ago, and will join a fleet of racing Astons that includes the Vantage GT2, GT4, DBR9 GT1 and the AMR-One LMP1.

Built around the Vantage aluminium VH bodyshell, the car will pack a lightweight, dry-sumped, 6.0-litre V12, which will put its power down via a semi-automatic, paddle shift Xtrac gearbox and the latest race-developed ABS and traction control systems.

John Gaw, Aston Martin Racing managing director said: 'The DBRS9 has been a very successful GT3 racing car and, despite being more than six-years old, is still competitive today. However, the competition has moved on and we needed to create a new car that combines our experience in this category with the latest

race technology to continue Aston Martin's success in GT3 for many years to come.'

Aston Martin Racing has set a target weight of 1250kg and target performance figures of more than 600bhp and 700Nm for the new car.

The first car will be completed in July 2011 and will undertake an extensive test and development programme during the rest of the year. 10 customer cars will then be built ready for delivery at the start of the 2012 season.



FORMULA 1

# Sauber raises cockpit safety concerns

**Swiss F1 outfit**, Sauber, has asked the FIA to look at cockpit safety after the freak incident that led to the retirement of one of its cars during the Malaysian Grand Prix.

Sauber driver, Sergio Perez, was lucky to escape injury when an unidentified piece of debris penetrated his cockpit at Sepang, luckily hitting the recently relocated ECU rather than the driver, but leading to the car's retirement.

Perez: 'I think it was something very unsafe. I was really lucky to get away with no injury after we saw what had happened to the chassis.

It came through very easily, so I am happy that nothing else happened to me... We didn't see what part it was, but reckon it was ballast, as nothing else could do such damage.'

The Mexican added: 'It was a very dangerous situation because it came into the computer software box and stopped just before my seat.'

Sauber has now sent photographs of the damage to the FIA. It is believed that the unidentified piece of debris initially damaged the front wing and the floor before entering the cockpit through the underside of the nose.

A new cockpit impact panel had already been made mandatory this year - following Timo Glock's injuries after his shunt at the 2009 Japanese Grand Prix - but it's thought this recent incident will lead to further discussions between the teams and the FIA on how cockpit safety can be improved.

### LOSING THEIR MARBLES

Meanwhile, drivers have also spoken out against the 'marbles' - the curls of worn away rubber that peel away from the tyres and then settle off line - which were a particular problem at the Malaysian Grand Prix.

Force India driver, Paul di Resta, was reported saying the marbles were so large they hurt when they were kicked up by cars in front and into the cockpit: 'Rubber kept hitting my hands in the middle of fast corners, and at that speed it's not the softest thing,' he told *The Daily Telegraph*. 'I imagine if you got it in the wrong place it could hurt a driver.'

CAUGHT

**The Honda Civic** driven by Gordon Sheddon in the BTCC was disqualified from the first round of the Donington Park triple header, and then put to the back of the grid for the second, after it was discovered that its turbocharge boost level had momentarily exceeded the 1.8bar maximum during the race.

### PENALTY: disqualification

**Both the Sauber F1 cars** were disqualified from their points-winning positions in the Australian Grand Prix after a radius on the upper rear wing element on the cars was found to contravene the regulations by a few millimetres. Sauber has now made changes to its legality check procedure.

### PENALTY: both cars disqualified

**NASCAR Sprint Cup** crew chief, Pete Rondeau, has been fined \$25,000 (£15,100) after an illegally attached weight was found on the no 78 Chevrolet he tends for Regan Smith. The infringement was discovered at the Autoclub Speedway Fontana, California.

### FINE: \$25,000

## Chevy's chase

**Chevrolet's 2012 IndyCar** engine is set to start its track testing in July with Penske Racing, the outfit which will be the American motor giant's lead team for its return to top line single-seater racing next year. Chevrolet is to join Honda and Lotus on the IndyCar grid in 2012, and series boss Randy Bernard has hinted that there may be even more engine manufacturers involved, having been quoted as saying, 'I want to see at least two more in the sport'.

## SEEN: BLOODHOUND DRAWINGS

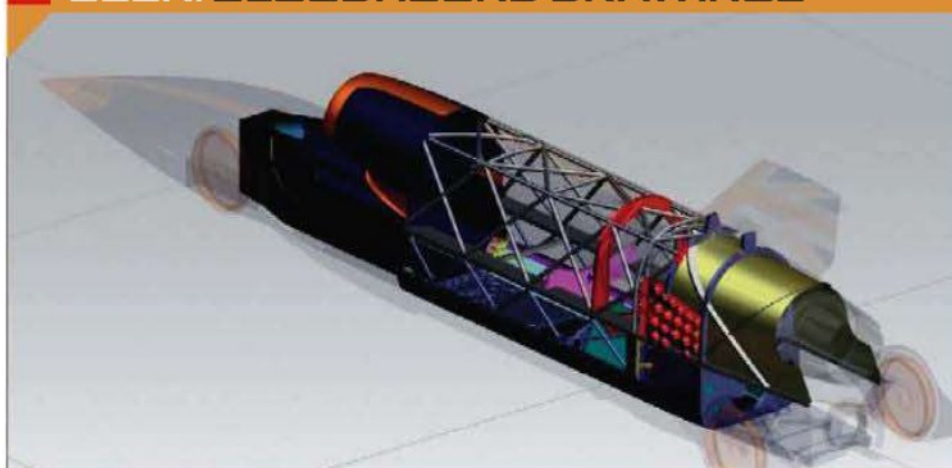

**In what must be** the scoop of the year, we've managed to get our hands on the full set of drawings for the Bloodhound SSC land speed record car... Well, actually the drawings are available to anyone and everyone online, thanks to those kind people at Bloodhound,

who are keen to make sure students can readily download the data. There are 4000 CAD drawings of individual components for you to download - go to [www.bloodhoundssc.com](http://www.bloodhoundssc.com) - and the software you'll need to view and manipulate them is available on the same site.

TOURING CARS

## Thorney hooked

**Thorney Motorsport** has announced it is to run Vauxhall Insignias in the BTCC later this season. The Insignia will be a new model for the BTCC and Thorney, which has plenty of experience at a club and national level, will build the cars to the new NGTC formula.

The team says it is looking at using the Swindon-developed TOCA engine, but that it has not ruled out building its own unit. Team boss, John Thorne, will drive one of the two Insignias the team will be entering.



# TOTAL SEAL®

High Performance  
PISTON RINGS

## The Leader in Piston Ring Innovation & Technology...

### Total Seal® Advanced Profiling™ Steel Rings

- Stronger and Longer Life – Most Precise Tolerances
- Thinner – Flatter – Lighter
- Conforms Better to the Cylinder Wall
- More Face & Anti-Friction Side Coatings
- Custom Sizing – Specialized Face Profiles
- Available In Gapless®, Napier or Conventional Styles

AP  
ADVANCED  
PROFILING™  
STEEL RINGS

### Total Seal® Diamond Finish® Rings

- Axial Tolerances of +/-1.27 Microns
- Improved Sealing Between Piston and Piston Ring
- Optional PVD Coatings
- Custom Axial Thickness Down to 0.6mm
- Available In Gapless®, Napier or Conventional Styles

### Total Seal® Gapless® Top\*\* or 2ND Rings

- Increased Horsepower and Torque
- Wider Torque Curve
- Longer Engine Life – Fewer Teardowns
- Improved Consistency – Longer Ring Life
- Cleaner, Cooler Engine Oil – Better Oil Control
- Less Friction – Increased Horsepower
- Increased Intake Signal – More Engine Vacuum

\*\* Patented

If you've got a ring problem, we offer the technical expertise and assistance to help give you the Total Seal® horsepower advantage!

### Home of the Gapless® Piston Ring

Total Seal® pioneered this horsepower producing technology over 40 years ago and has been perfecting it ever since. Available in both our patented Top or 2nd ring applications.

UK distributor:  
PERFORMANCE UNLIMITED

Phone +44 (0) 1904 489332

Fax +44 (0) 1904 488355

e-mail [info@performanceunlimited.co.uk](mailto:info@performanceunlimited.co.uk)

[www.performanceunlimited.co.uk](http://www.performanceunlimited.co.uk)



Available from:  
**Total Seal, Inc.**  
[www.TotalSeal.com](http://www.TotalSeal.com)  
**800-874-2753 (U.S.A.)**  
**Tech Line: 623-587-7400**

\* U.S. Patent No. 6899595, U.S. Patent No. 7207870,  
U.S. Patent No. 7267602

## ALTERNATIVE POWERTRAIN

# New LEAF of life for Nissan's electric runabout

**Nissan recently** unveiled this all-new electric racecar, which the Japanese manufacturer says it intends to use as a development platform and as a catalyst for a new green motorsport series.

The car is called the Nissan LEAF RC and is derived from the company's mass market electric vehicle, with a powertrain based around a lithium-ion battery system.

Nissan says it is now looking at motorsport as a way to draw attention to its EV technology. Carlos Tavares, chairman of Nissan America, said: 'Combining the talents of NISMO, Nissan's world renowned motorsports

group, and engineers behind some of the company's Super GT and FIA GT1 race teams, the Nissan LEAF NISMO RC will serve as a rolling laboratory for the accelerated development of EV and aerodynamic systems, as well as a platform for the development of new green motorsports series.'

The Japanese firm says the car will probably form the basis of a one-make series at some time in the next couple of years but, for the foreseeable future, will just be demonstrated at various motorsport events throughout 2011.

Nissan's LEAF RC

**Yet another one-make series could be heading our way...**



boasts a full carbon fibre monocoque body and is said to weigh some 40 per cent less than the roadgoing version. The layout of the RC is also very different from the production saloon, with a mid-ship location for

the battery pack, electric motor and inverter and rear-wheel drive. Suspension is double wishbone front and rear.

Power comes from a lithium-ion battery composed of 48 compact modules and a high-

response 80kW AC synchronous motor that generates 107bhp and 207lb.ft of torque. It can be charged up to 80 per cent of its full capacity in 30 minutes using a quick charging port located inside the rear cowl.

## TOURING CARS

## NGTC cars to be allowed extra testing

**The BTCC is to give** its Next Generation Touring Car (NGTC) runners the chance of some extra testing in an effort to improve both pace and reliability.

NGTC runners have so far struggled in early races, mainly because of a lack of track time, so the three teams that run the cars have now been allowed to run them outside the BTCC's strict testing restrictions - on the proviso they notify the BTCC of their intentions first.

The three teams running the NGTC-spec cars are Dynojet and Speedworks Motorsport, both of which are running the Toyota Avensis - the chassis on which the NGTC concept was developed - and Rob Austin Racing, which runs an Audi A4.

Dynojet's Avensis has been the fastest of the NGTC cars so far, showing reasonable pace but being let down by reliability. Dynojet's Frank Wrathall jr posted

some impressive lap times at Donington, despite being forced to start two races mid-race from the pit lane as the team completed work replacing an exhaust manifold and then after a gear linkage broke on the way to the grid.

'We showed our progress throughout the weekend, and in the final race I lapped strongly in traffic and was even being held up by Matt Neal and Jason Plato, which was a good feeling,' said Wrathall. 'The steps forward we have made this weekend have been bigger than I could ever have imagined.'

NGTC cars use a 2.0-litre turbocharged engine and common electronics, gearboxes, brakes and suspension, with the aim of cutting the running and development costs. There is to be performance parity between the NGTC and the S2000 cars until 2013.

## TOURING CARS



## A very quick fix

**The RML crew that tends** Jason Plato's Chevrolet Cruze in the BTCC deserve a special mention in *Racecar Engineering* dispatches. Plato all but destroyed the car in a frightening-looking series of rolls in the second race at the Donington meeting, yet within two hours was lined up for race three and went on to finish sixth. Team manager, Rod Underwood, said: 'We had to give it our best shot. We didn't think there was a hope of getting the car out at first, but somehow it all came together and we did it. I'm still not quite sure how - two hours to fully rebuild a car, most of which was broken!'



# The one in the middle wins races



## DS1.11 & DS2.11

### SILOXANE TECHNOLOGY

### BRAKE PADS



**FEDERAL MOGUL**

The best brands in the business

Relative Performance Characteristics of Ferodo Racing Range Under Heavy-Duty Conditions

	Pad Life	Disk Life	Average $\mu$	Fade	Pedal Travel	Release
DS 2500	Good	Good	Good	Good	Good	Good
DS 3000	Good	Good	Good	Good	Good	Good
DS 3000-03	Good	Good	Good	Good	Good	Good
DS 3000E	Excellent	Good	Good	Good	Good	Good
FER 4003	Good	Good	Good	Good	Good	Good
DS 1.11	Excellent	Good	Good	Good	Good	Good
DS 2.11	Excellent	Good	Good	Good	Good	Good

Excellent  
Good  
Moderate

[www.federal-mogul.com/ferodoracing](http://www.federal-mogul.com/ferodoracing)

#### Race Proven

- DS1.11 - suffix "W"
- A1GP
- FIA FT
- Touring Cars
- Formula Cars
- Group N
- Stock Cars
- DS2.11 - suffix "X"
- WRC
- Rally Group N
- Touring Cars



**Circuit Supplies (UK) Ltd**

Unit 8, Eden Court, Eden Way

Leighton Buzzard, Beds LU7 4FY

Tel: 01525 385 888 Fax: 01525 385 898

[info@circuitsupplies.com](mailto:info@circuitsupplies.com) [www.circuitsupplies.com](http://www.circuitsupplies.com)

## HARDWARE

## PIPERCROSS FILTERS

**UK-based induction specialist,** Pipcros, has released details of its latest range of competition-spec filters. The diverse selection has been designed to offer a variety of solutions for race teams, car preparation outfits and specialist car builders. Literally dozens of different combinations

of neck and filter diameter are available, ranging from 50-146mm necks with filter sizes from 100-300mm.

Also available are a range of base plates and matching filters for carb and throttle body applications. All Pipcros filters come with a lifetime warranty and are reusable.

**For more information see** [www.pipcros.com](http://www.pipcros.com)



## CHASSIS

## NEW EIBACH CATALOGUE

**Respected German suspension manufacturer,** Eibach, has released its 2011 trade and retail catalogue. At 243 pages, it contains a wealth of information, including the latest updates on fitments for its extensive range of spring, matched dampers, coilover kits, anti-roll bars and wheel spacers.

With almost 200 new lines introduced since last year's catalogue, the product range is vast and features clear listings and measurement guides to aid the end user. As an added bonus, Eibach has even managed to hold its 2010 prices for 2011.

**For more information see** [www.eibach.com](http://www.eibach.com)

## MANUFACTURING

## MULTI-TASKING MAZAK

**Machine tool manufacturer,** Yamazaki Mazak, has launched the seventh generation of its successful Integrex range of multi-tasking machines, the i-series. Mazak was the first company to produce a machine that could complete all turning and machining operations

from raw material to finished component in one set up and on one machine and has sold over 10,000 of them since their introduction in 1993.

The latest range of machines are available in three different sizes and come equipped with a significantly larger working area than previously, particularly in the y axis which has a range of up to 250mm, along with 615mm in the x axis and a b-axis range of 240 degrees.

**For more information see** [www.mazak.eu](http://www.mazak.eu)



## PIT EQUIPMENT

## LONGACRE SET UP KIT

**Renowned set-up equipment supplier,** Longacre Racing Products, recently released two new products, adding to the company's already extensive range of chassis tools. First up is a new, miniature chassis height checker, a simplified version of the company's full-size checker. Accurate to 1/16in (1.6mm), the tool is able to measure heights from 2-8in (50-200mm).

The second product is a new toe bar, for checking wheel toe in / out. Suitable for wide track vehicles, the bar is adjustable up to 88in (2235mm) and durable too, thanks to being constructed from T6 aluminium.

**For more information see** [www.longacreracing.com](http://www.longacreracing.com)



## POWERTRAIN

## TREND TOOL STEEL TAPPETS

**US-based Trend Performance** has announced a new, tool steel flat tappet, intended for use with cast iron camshafts in Chevrolet, Ford, Chrysler and Toyota V8s.

Said to be ideal for engines turning in excess of 7000rpm with high valve spring pressures, these new tappets are ideal for short track oval racing, bracket racing and high performance street use. As direct derivatives of Trend's successful NASCAR tool steel tappets, their chief advantage is they can be re-used many times, and can also be rebuilt and have their crowns re-ground by returning them to Trend Performance for

refurbishment when necessary.

The tappets have a 0.0015in crown with a radius of between 50 and 60in, and are finished to a super fine surface finish. They are also available with an optional 0.16in EDM oil hole in the foot or contact area.



**For more information see** [www.trendperform.com](http://www.trendperform.com)

## HARDWARE

## GOODRIDGE G-COOL

**UK-based Goodridge Ltd,** the fluid transfer systems specialist, has released its latest range of G-Cool fluid coolers. These lightweight auxiliary coolers have been specifically designed to meet the requirements of all racers and tuners, from professional car builders to weekend warriors. The coolers

are available in two thicknesses - 19mm and 37mm - and are suitable for cooling oil, water or fuel. A range of sizes are available, with up to 32 rows of cooling fins and connections ranging from -6 to -12 JIC.

**For more information see** [www.goodridge.net](http://www.goodridge.net)



# Less horses, more prancing

BY MARSHALL PRUETT

Ferrari has finally responded to calls from its clients to replace the F430 GT2 racer with the comprehensively updated F458. Despite a late launch, it was clearly the right move



“ the 458 is a very good road car, so our job was easy ”

**W**ith two class wins at Le Mans and numerous championships in Europe and North America, Ferrari's F430 racer took the fight for supremacy in the hotly contested GT2 category to its nemesis, Porsche.

Except for the brief period during the 1990s when Ferrari's F40 GT-LM was considered a worthy contender on the GT racing scene, Porsche's various production-based racecars owned the lower tiers of GT competition, until the F430 moved to the forefront in 2008 and 2009.

That brief taste of glory was parried back by Weissach in 2010, with 997 RSRs winning their class at Le Mans, while championships in the ALMS and LMS drove the final nails

into the F430's coffin.

Ferrari had its nose bloodied, and had to respond with something special. Luigi Dindo, Michelotto's chief engineer for the F458 GTC programme, says that with the F430 at the end of its development cycle, sweeping changes were saved for the new-for-2011 F458. Rather than carry over proven elements of the F430, every section of the F458 was treated with a brand new approach.

'First of all, the 458 is a very good road car, so our job was easy,' says Dindo. 'The target was to improve each aspect of the 430. First, the V8 engine, which, because it is production-based, uses direct injection to improve fuel consumption. And we tried to improve power and torque, because the new

motor is 4.5-litres instead of the 4.0-litres of the 430. Also, at the end the target was to make everything lighter. So we tried as much as possible on the engine to reduce weight without making crazy things, because it is a GT class for customers, not a works team.'

#### LESS POWER

The ACO's move to slow the GT2 class for 2011 resulted in the F458's bigger engine producing almost 100bhp less than its road-going counterpart - approximately 470bhp at 6250rpm, thanks to dual 28.3mm air restrictors. Utilising four chain-driven cams and four valves per cylinder, the engine, code named F142, generates roughly 520Nm of torque at 5750rpm. Cast from aluminum, the dry-sumped F142 uses the lightweight metal

almost exclusively, except for its steel connecting rods and forged steel crankshaft.

Dindo says the 4.5-litre motor has seen as much as a two per cent improvement in fuel economy with the use of direct injection, and that the 90-degree V8, fed from a 90-litre fuel cell, was designed to swap between a variety of fuels, including E85

ethanol and E10, depending on the series the F458 competes in.

'[Direct-injection] is not a big step because the primary goal at higher revs with the high-pressure pumps is to give some extra power, so it is between a 1.5 and two per cent improvement in race conditions,' says Dindo. 'Where you have open throttle, when you have a partial

load, the difference is higher but also it depends on the circuit and how much the driver is on or off the throttle.'

While the F458 produces more power than the F430 it replaces, it carries extra weight compared to early versions of its predecessor, tipping the scales at the ACO's 2011-mandated 1245kg which allows it to run

larger tyres. The need to shed weight and to optimise weight distribution led to the F458's six-speed sequential Hewland gearbox receiving a lot of attention, as Dindo explains:

'For the gearbox, we wanted a quicker shift mechanism, and Hewland was able to give us a lighter gearbox case and gear cluster. We also wanted a lower

## TECH SPEC

**Length:** 4518mm

**Width:** 2036mm

**Height:** 1160mm

**Wheelbase:** 2650mm

**Front track:** 1720mm

**Rear track:** 1688mm

**Dry weight:** 1245kg

**Tyres:** front – 325/650-18 Pirelli or 300/650-18 Michelin or 300/660-18 Dunlop; rear – 325/705-18 Pirelli or 310/710-18 Michelin or 310/710-18 Dunlop

**Engine:** naturally aspirated, 90-degree V8; 4498cc; direct injection

**Block:** aluminium

**Bore:** 94mm

**Stroke:** 81mm

**Maximum power:** 346.75Kw (465bhp) at 6250rpm

**Maximum torque:** 520Nm at 5750rpm

**Transmission:** Hewland six-speed sequential

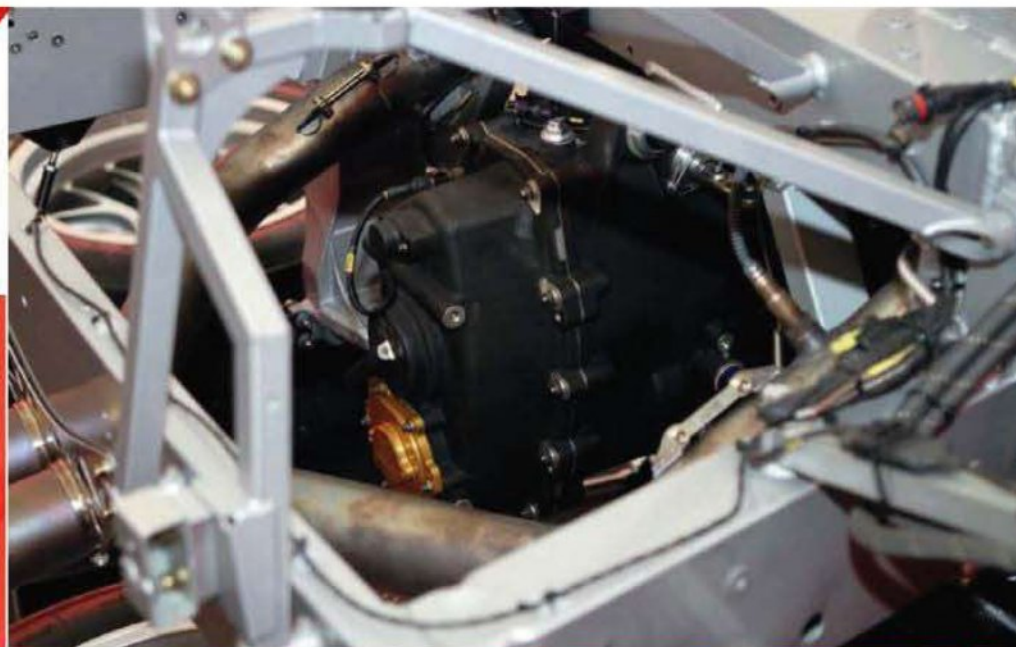

A heavier engine meant weight had to be saved in other areas to redress the balance. Hewland came up with a lighter six-speed sequential 'box with the added bonus of a lower centre of mass



center of mass on the gearbox, and we have been able to get it. It was also made stronger because of the increased torque of the engine.'

### LOOKS FAMILIAR

The F458 looks similar in some ways to the F430 but, barring the cabin's interior, the majority of the chassis, major systems

and placement of the ancillaries have been re-worked. It would be a stretch to call the mid-engined two seater a completely new design, but the majority of the underpinnings and the body panels are different enough to stand out in a direct comparison.

'About the chassis, we wanted to improve the suspension design with the same philosophy. Now

there is a race suspension on the car with fabricated uprights and control arms, we no longer use the production control arms of the road car. For the rest of the car, we did not so much try to change the major concepts, only to put the weight as far at the bottom and to make the car very light.'

Beyond the change in construction methods, the F458's multi-link suspension underwent possibly the most radical re-design of any aspect on the car, with revised geometry and optimised c of g and polar moment of inertia. The move to wider 12.5 x 18in front wheels, adopted by most contenders in the category, also helped alter the F458's balance, while the rear wheels are slightly wider too, at 13 x 18in. Both Michelin and Dunlop offer tyre options for the car and, while tyre sizes vary slightly between the French and British rubber up front, with Michelin's 300/650-18 units offering a shorter sidewall than Dunlop's 300/660-18 provide, both make a 310/710-18 for the rear. Controlling the wider fronts is aided by the F458's electro-hydraulic power steering system.

Brembo brakes are used, with six-piston calipers and 380 x 35mm steel front discs, with four-piston, 332 x 32mm units at the rear leading to very different handling characteristics for the new car compared to its predecessor.

### AERO CHANGES

Aerodynamically, the F458 is considerably different to the

F430. The latter manifested a number of aerodynamic add ons over the years, with a variety of flicks, dive planes and floor revisions used to keep pace with class development, but the car's overall downforce levels was always a question mark. With the F458, many of the F430's sleek and flowing lines have been replaced with more abrupt, rakish transitions, designed to produce more downforce from nose to tail. 'We concentrated very much on the aerodynamics, trying to improve the already very good parameters of efficiency of the 430,' says Dindo. 'At the moment it's a little bit more resistant than the 430 and so is slower on the straight, but we're working on that side to match the speed of the 430 at least. However, it has a little bit more downforce, which should make the car quicker in the slow and medium-speed circuits. [The reason] why, at the moment, we are suffering in the high-speed circuits is being investigated, but we are working to get a new kit for Le Mans.'

Asked if Michelotto had quantified top speed issues as being more downforce or drag-related, Dindo confirmed his team will be looking for ways to carve as many excess pounds of drag off the F458 as possible: 'I think the downforce is a little bit more than the 430, but it's not the problem. The car is wider because of the bigger tyres, so we needed to get back some drag to compensate the wider front surface. So we work not to reduce the downforce



The whole suspension and chassis has been re-engineered, and attention has been paid to keeping weight as low as possible in the chassis



Gone are the production suspension components of the 430, in their place a purpose-designed race set up, with fabricated uprights and control arms



**killer instincts.**

**.2 seconds Quicker  
or your money back\***

USA 866 392 9936

[www.PerformanceFriction.com](http://www.PerformanceFriction.com)

[motorsportsteam@performancefriction.com](mailto:motorsportsteam@performancefriction.com)

© Copyright Performance Friction 2010.

\*see website for terms and conditions.

**PERFORMANCE<sup>®</sup>  
FRICTION  
BRAKES**

**MADE IN THE USA**





The 458's multi-link suspension underwent the most radical re-design of all, with revised geometry and optimised c of g and polar moment of inertia, making the new car an entirely different handling racecar to the 430 it replaces

but reducing the Cd.'

Engine cooling philosophies also changed radically between the F430 and F458, with the new car utilising much larger openings in the nose and an articulated radiator venting system designed into the bonnet. The F430's wide, boxy front chassis section prevented the use of a large, central radiator, so two smaller units were adopted at the outer edges of the nose in front of the wheels, while an even smaller oil cooler was somewhat clumsily plumbed through the limited space under the bonnet.

With the F458, the front of the chassis was designed from the outset to reverse this trend, and makes use of a large, steeply inclined water radiator, while there are two smaller coolers in front of the wheels.

As well as presenting possibly the least appealing visual aspect of the F458, these various openings also likely contribute to the excessive aerodynamic drag the car currently suffers from.

While most manufacturers go to great lengths to ensure bonnet venting directs as much air as possible around the cabin sides, the F458 sends a large volume of hot air from the water radiator straight over the greenhouse, adding to its drag issues.

The F458 follows the trend for 2011 of exposing as much of the

outer portions of the front and rear wheels as the rules allow. After pushing the boundaries in this area last year the new car exploits the flow-through benefits as much as possible, helping to extract air from the diffuser.

#### ELECTRONIC SWITCH

After years of patronising Italy's famed racing electronics firm, Magnetti Marelli, the F458 has made the move to Bosch. 'We made the biggest step forward compared to the 430, aside from the suspension, when

**»» The car should be looked at like a young driver starting his first days on the job »»**

we changed the electronics from Magnetti Marelli to Bosch Motorsport, because they had better software and better electronics. And also the electrical wiring has a power box, so it is a multiplexing system, which is common on racecars now. We wanted that on the 458.'

The Bosch MS5.1 system also provides a robust traction control system. Based on Corvette Racing's similar switch for 2011, it has become the package of choice in GT racing.

The one limiting factor in

the F458's performances at the 12 Hours of Sebring stemmed from the late delivery of the initial batch of cars. Jaime Melo qualified fifth at Sebring for Risi Competizione, but in the race, mechanical and electrical gremlins plagued both the Risi team and the Extreme Speed Motorsports entries. Gianmaria Bruni set pole at the European LMS race at Paul Ricard, but the development has a long way to go.

'The problem is the car arrived very late. If it arrived two months earlier, we would be in better shape,' said Dindo, who

oversaw the first test of the car at the end of November. 'In this condition, we are producing the car, we are racing and we are testing to improve reliability at the same time. For sure, the car is young and should be looked at like a young driver or young man starting his first days on the job.'

#### DRIVING IMPRESSIONS

With all of the work that has been put into the F458 and the 20 cars Michelotto will build this year, and despite the car being at the very beginning of its

development curve, British driver Rob Bell says the differences he's found from a driving standpoint are night and day. 'The first time I drove the 458 was the test car at Vallelunga in early March. My first impression was that the car is definitely a more stable platform to work with. At times the 430 was quite edgy. And that was because they made a suspension change in 2008 based around the American scene because they didn't use tyre warmers there. The 430 then changed suspension to work the tyres harder to get heat into them because they were losing out over the first three or four laps in the ALMS. So when they did that it made the 430 a lively car at the rear. But then what it also meant was halfway through the stint the tyres would be reacting and working harder and not necessarily being able to keep up with the suspension.

'So you had a situation where a lot of the time when cornering the 430, the front would work into the corner but the rear would be coming round. But straight away, driving the 458, that issue seems to have disappeared altogether. It felt very, very stable on brakes and turning at the rear, which was our biggest concern when we finished with the 430. The car is a flatter car to drive, which is great in the high-speed



stuff, really nice. The 458 is a case of, "wow, you can really attack the corner now and get turned in and be aggressive and not worry about the rear losing grip". It's a big step forward, for sure.'

Comparing the cornering attributes of the F430s and F458s at the 12 Hours of Sebring revealed how much Michelotto has accomplished by altering the ride quality of the new car. Where the F430s always used a bit of extra roll and dive to load the tyres and transfer weight, the F458 moves visibly less while cornering and under hard braking. Simply put, the normally demonstrative moves of the Prancing Horse have been muted.

After listening in to a number of conversations in the pit lane amongst F458 drivers, perhaps too much anti-dive geometry has been used, leading to the rather numb handling sensation some drivers reported, so it is believed the first batch of updates for the F458 will include geometry revisions to mitigate this.

Bell, who took the F458's first major international win at the Paul Ricard in April, says his JMW team worked through a number of changes at the French circuit to try and improve the car's straight-line limitations. 'First, we've all got a new, taller Gurney on the rear now, and it's quite obvious when you get up to a certain speed that it's doing its job. It's been put there to slow us down, and it does. You definitely feel like you get into top gear and not a lot really happens. So I would say that's been true with most of the cars. Having said that, in the past with the Ferrari, when you've taken aero out of it, it's responded very well. But I think the truth will be known at Le Mans, when we start taking aero off. We took a little bit off at Paul Ricard and played with bits and bobs, and didn't really find a huge amount, to be honest. It's little stuff we're looking to improve, and Michelotto will get it sorted quickly, like they always do.'

Bell also reported that the change to the Bosch MS5.1

system has been seamless so far: 'For a completely new system it's been a very smooth transition. And certainly everything that we've had so far has worked perfectly. You'd expect electronic glitches for the first six months, but we haven't really had any on the cars I've driven. And I think it's a step forward because, for example, the traction control system is more advanced. It's a nicer system to work with as a driver, and that can only be good - we don't necessarily rely on traction control but, if it's there

and you don't feel it's working, it's going to be looking after the tyres better than we humanly can. I think that will be seen in long durations, as it does seem to be doing its job. The Marelli system was fine, but for example its traction control felt a bit basic.'

There's no doubt the F458 has a long way to go to catch and surpass the F430's record in competition but, if it's early potential is anything to go by, it looks like Munich and Detroit might have another five years of hellish fighting ahead. 

## TYRE CHOICE

After racing Extreme Speed's F458 at Sebring on Michelins and winning Paul Ricard in JMW's Dunlop-shod F458, British driver Rob Bell says the advanced state of tyre technology from both companies give Ferrari racers an excellent choice.

'Michelin has been there for years. They are the benchmark that everyone aims for, but I've done a lot of work with Dunlop over the last five or six years and I think they're knocking on the door. They've won the first two major races of the year [Sebring and Paul Ricard], so they've done their sums. They're both good companies, though, and their products both work very well on the car. The only thing I would say is, I suppose Michelin have about six months on the car ahead of Dunlop.

And there's a slight difference in balance - one seems to be slightly stronger at front grip, the other is slightly stronger at rear grip. In the grand scheme of things, they've both done a great job.

'When you get down to the finite, real last few per cent of tyre performance, that's really getting down to the last one or two tenths per lap. Both seem to last very well on the car and again, only time will tell, but maybe the car is just good on its tyres. We're still gathering data at the minute, and we don't really know the answer, I guess because we've not had a really hot day, but Sebring is a pretty hard test on tyres and they lasted pretty well. Again, at Ricard, the tyre consistency was very good, so I think both have got parity at the minute.'



With a choice of either Michelin or Dunlop tyres, drivers have two excellent products on offer that, in early tests, have shown remarkable parity

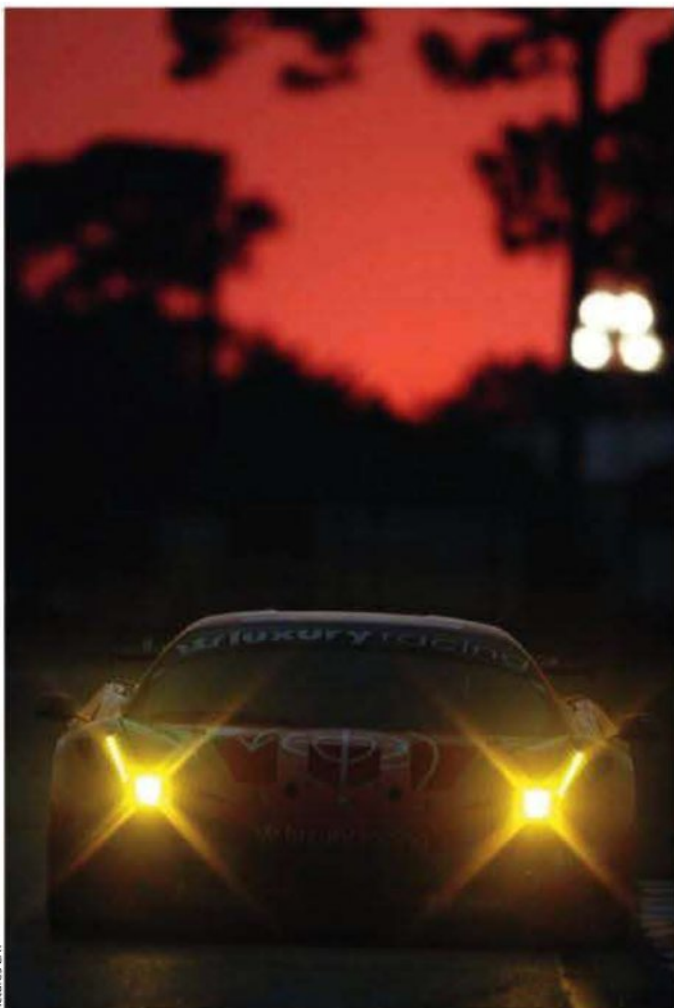

# ENDLESS PADS FOR F458

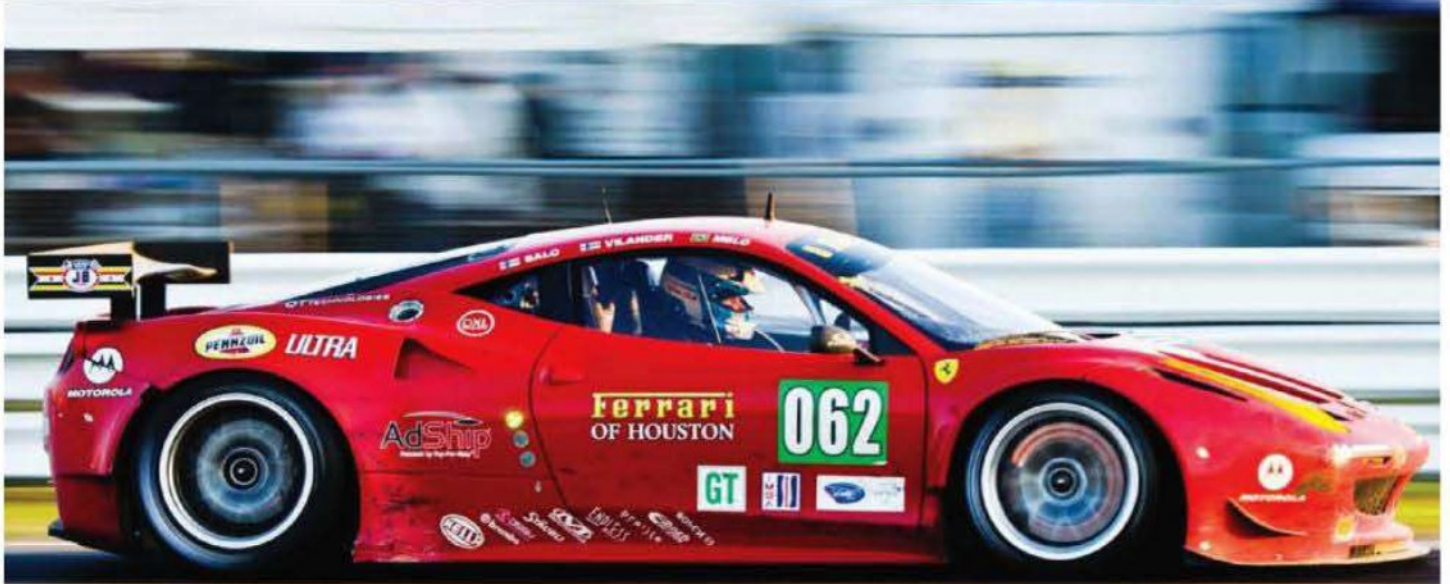

Photo by James Boone



Lower your pulse, rely on your brakes.

Endless Europe - [www.endless-brakes.info](http://www.endless-brakes.info)  
[info@endless-brake.info](mailto:info@endless-brake.info)  
+46 171 443488

**ENDLESS**<sup>®</sup>  
ADVANCED RACING BRAKE TECHNOLOGY

## Öhlins...24hrs race success



Öhlins latest TTX technology offers unrivalled performance that leads to improved driver control and 24hrs race success.



Öhlins Racing UK - Chris Witter +44 (0) 203 286 3127  
[chris.witter@ohlins.se](mailto:chris.witter@ohlins.se)

Öhlins Racing AB - Office: Instrumentvägen 8-10  
Box 722 SE194 27 Upplands Väsby - Sweden

**ÖHLINS**<sup>®</sup>  
ADVANCED SUSPENSION TECHNOLOGY  
[www.ohlins.com](http://www.ohlins.com)

# MAKE THE DIFFERENCE



Make the difference in your Porsche engine project with superior quality of Saenz connecting rods. Tailor made in steel or Titanium, Saenz offers what you are looking for. Not from the shelf, just what you want.

Top Quality  
**SAENZ**  
CONNECTING RODS

Jacquemin Tuning - 233 avenue de la république - 59110 La Madeleine - France - +33 (3) 20746480 -  
www.jacquemintuning.com - info@jacquemintuning.com

*Great things don't change, they evolve.*

**VAC**  
MOTORSPORTS  
.COM

**VAC**  
MOTORSPORTS

*World Leading BMW Performance*



**Vanos Elimination Kits**  
**Race Seat Installation Kits**  
**Underdrive Pulley Sets**  
**Racing Oil Pumps**  
**Dry Sump Kits**  
**Oil Cooler Kits**



*VAC supplies engineered BMW solutions for racing. With over 25 years of experience, our components have been used successfully in racing cars all over the world.*



**APEX**  
Racing Wheels

**ARP**  
automotive racing products

**SCHRICK**  
MEMBER OF THE AVL GROUP

**COMETIC**  
GASKET

**KMS**  
Kronenburg  
Management System



**Online store with over 3000 Products**



[www.vacmotorsports.com](http://www.vacmotorsports.com)

Tel: 215.462.4666

Phila, PA USA



FIRST PRINCIPLES

**Simon McBeath** offers aerodynamic advisory services under his own brand of SM Aerotechniques - [www.sm-aerotechniques.co.uk](http://www.sm-aerotechniques.co.uk). In these pages he uses data from MIRA to discuss common aerodynamic issues faced by racecar engineers

Produced in association with MIRA Ltd



**Tel:** +44 (0) 2476 355000  
**Email:** [enquiries@mira.co.uk](mailto:enquiries@mira.co.uk)  
**Website:** [www.mira.co.uk](http://www.mira.co.uk)

# More wind tunnel surprises

Why using a full-scale wind tunnel is so much better than guesswork

In the last issue we saw how 'flip ups' on the outer face of the DJ Firestorm's front wing end plates acted in a similar way to dive planes on a closed-wheel car. That is, they shifted the aerodynamic balance of downforce towards the front, although with a useful

1.3 per cent drag reduction rather than the usual drag penalty seen with dive planes. So, what would rear wheel flip ups mounted on the sidepods and directing air over the rear wheels of the Firestorm achieve? Table 1,

below, shows the changes to the coefficients, relative to the previous configuration, brought about by the simple curved flip ups shown in the photo (note: a 'count' is equivalent to a

airflow over the rear of the car, and might reasonably have been expected to have produced an increment of rear-biased downforce. It actually saw an increase in front downforce,

albeit modest, and a decrease in rear downforce, with a commensurate forward shift in aerodynamic balance. Furthermore, drag

appeared not to change. So what might be the explanation for this?

Taking the drag first, a decrease in drag might have been expected by virtue of the flip up directing some of the air that would have impacted upon the

“ a lower leading edge might have had more effect on drag ”

coefficient change of 0.001, so 20 counts = a change of 0.020).

This was one of the more surprising results from this session. A device fitted aft of the roll hoop would have been expected to have altered the

TABLE 1

	CD	-CL	-CLfront	-CLrear	%front	-L/D
<b>Change counts</b>	+1	+5	+18	-12	+0.81	+3
<b>Change, %</b>	+0.1%	+0.3%	+2.2%	-1.1%	+1.9%	+0.1%

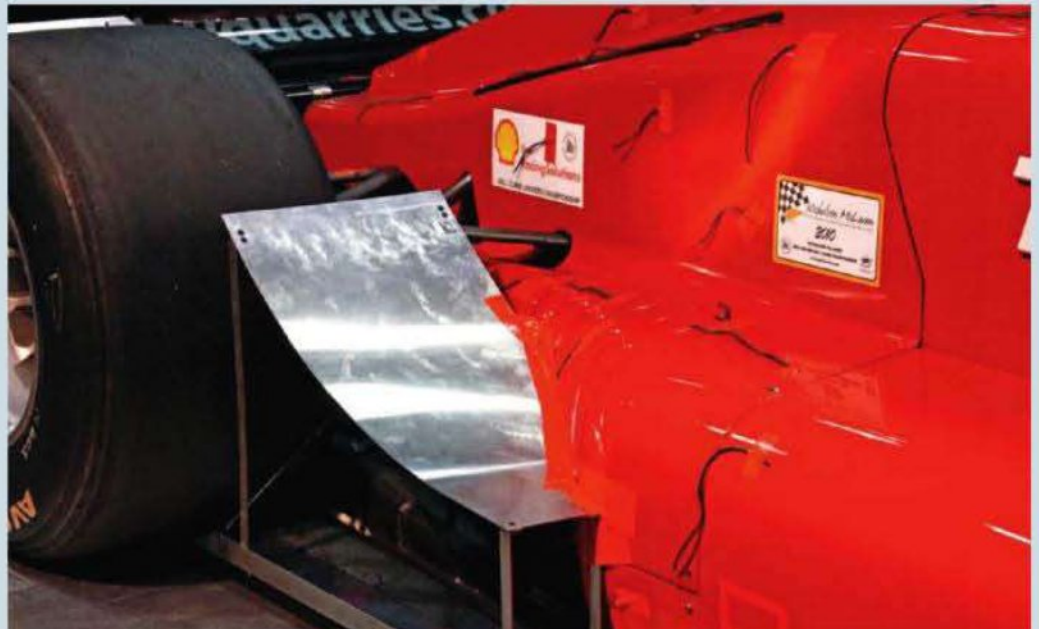

The first iteration of the rear wheel flip up on the DJ Firestorm

**TABLE 2**

	CD	-CL	-CLfront	-CLrear	%front	-L/D
<b>Change, counts</b>	+3	+23	+11	+12	+0.06	+18
<b>Change, %</b>	+0.3%	+1.2%	+1.3%	+1.1%	+0.1%	+0.8%

rear wheels over them instead. Perhaps, though, the leading edge of the flip up was a bit too high to achieve as much benefit as hoped here? The raised pressure area on the front of the tyres being located above and below axle height, and the flip up leading edge was roughly at axle height. With the benefit of hindsight, a lower leading edge *might* have had more effect on drag. Perhaps too, given that the rear wheels are partly in the wake of the front wheels, less benefit in this respect might well be expected anyway.

## REAR DOWNFORCE

Looking next at the reduction in rear downforce, note that the outer edge of the flip ups was 700mm from the car's centreline in order to comply with the maximum allowed body width behind the front axle of 1400mm. The rear wing, too, complied with this rule, and so was the same width. The flip ups also extended inboard of the inside face of the rear tyres by a few centimetres. As such, the flip ups would have been affecting the airflow that impinged downstream on the outer portions of the rear wing assembly, which comprised upper and lower dual-element tiers. Perhaps the best guess on specific mechanisms here is that the wake from the inner portion of the flip ups was adversely affecting the lower wing tier but, whatever the exact cause, the general idea of an adverse effect on the rear wing was then tested out, as we shall see shortly.

## EXPLAINING THE GAIN

Meantime, how could the gain in front downforce be explained? The first thought might be that this was simply the mechanical consequence of losing some downforce at the rear, and the reduced leverage at the rear manifested as a little extra vertical force on the front wheels.



The airflow passing over the rear of the sidepods and flip ups quite clearly encountered the rear wing further downstream



Viewed through the MIRA wind tunnel's flow-straightening screen, it is evident that the narrower flip ups could beneficially be further reduced in width on the inboard side to reduce the effect on the lower wing tier

This is perhaps borne out by the fact that the whole of the flip up was aft of the mid-point between the front and rear under-wheel load cells, and therefore it would be unable to actually exert downforce itself on the front axle. However, the front-end gain in downforce was greater than the rear loss. Was this simply

down to the cantilever effect again? The rear wing overhang was not large, but maybe this would explain it. Having said that, trials with alterations to the rear wing that produced large rear downforce changes only made small front-end downforce changes. For example, one rear wing change gained 80 counts

**flow off the inside edge of the flip ups was having an adverse effect on the rear wing**

of rear downforce with a loss of just 18 counts of front downforce – a very different ratio to that caused by these flip ups! So we are left with the only remaining conclusion: that the rear flip ups probably also affected the airflow upstream in such a way as to actually cause a genuine increase in front downforce, perhaps by causing an increase in mass flow under the front wing or through the forward section of the underbody.

Going back to the idea that the inner portion of the rear flip ups was likely causing an adverse effect on some parts of the rear wing, this theory was tested by cutting off the inner few centimetres of the flip ups. This time, the results in terms of change relative to the same pre-flip up configuration as the above results, were as shown in table 2, above.

## A PROFOUND DIFFERENCE

So, although the overall effects were still relatively modest in the context of this particular car, the difference that trimming a few centimetres off the inside of the flip ups made was quite profound. Again, drag could be said to have changed negligibly, but overall downforce went up and this time there was minimal balance shift, with both front and rear downforce increasing in almost equal amounts. The fact that rear downforce *increased* by 12 counts, rather than decreasing by 12 counts, suggested that the flow off the inside edge of the flip ups was indeed originally having an adverse effect on the rear wing.

The fact that front downforce increased at the same time as rear downforce also reinforced the idea that somehow these rear wheel flip ups were genuinely affecting the airflow in a way that produced some front-biased downforce, and that the effect seen in the first part of this trial was not just down to mechanical leverage. <sup>®</sup>

Racecar Engineering's thanks to Wallace Menzies and all at DJ Engineering Services Ltd



SHELL **RACING** SOLUTIONS

## Bringing Technology Together.

### Supply

In-house production and global reach of specific and reliable fluids

### Technology

Product development and technical support for cutting-edge technologies

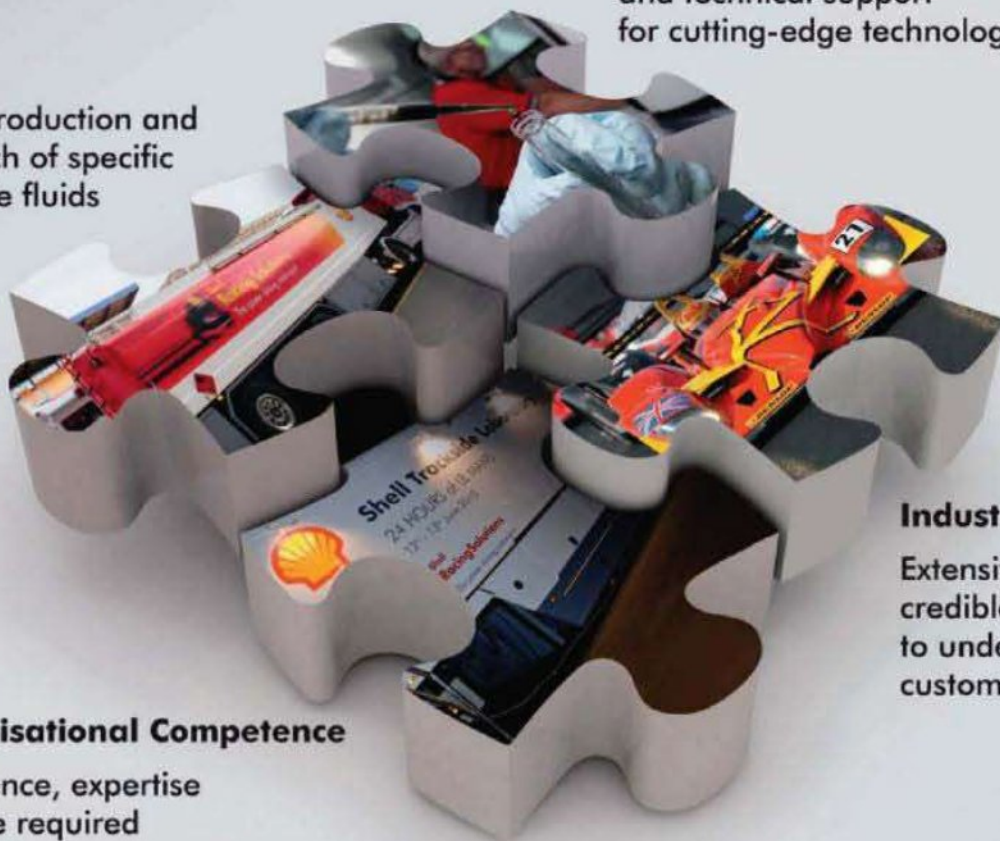

### Organisational Competence

Experience, expertise and the required speed of response

### Industry Knowledge

Extensive network and credible partnerships to understand the customers' needs

## Race Fuels. Race Lubricants.

Exclusive UK distributors

One-Fuel Ltd.

Unit 1, Control Tower

Wolverhampton Business Airport

Bobington, South Staffs

DY7 5DY.

T:01384 90 40 31

E:sales@onefuel.co.uk

[www.shellracingsolutions.co.uk](http://www.shellracingsolutions.co.uk)



**Ferrea**  
RACING COMPONENTS

# Competition

## Hollow Stem Valves

LIGHTER | STRONGER | FASTER = MORE POWER



Ferrea Racing Competition Plus Hollow Stem Valves are 22% lighter than conventional stainless steel alloy valves. Their proprietary manufacturing process gun drills and micro polishes the bore of the valve stem. These valves are also made from Super Alloy materials which resist heat much better than conventional Inconel materials.

- Friction Welded Tips
- Radial Grooves
- Avionic Chrome Plated Stems
- Seat Hardness up to 42 HRc
- Super Flo Design to Improve Flow
- Available in 5/16, 11/32 & 3/8 Stem Diameters or Semi Finished Blanks

22% lighter than conventional stainless steel alloy valves



Download your QR Reader app to your smartphone to scan our code for more exclusive information.

FOLLOW US ON:  

FERREA RACING COMPONENTS

Tech Line: 954-733-2505 • Toll Free: 888-733-2505 • [www.ferrea.com](http://www.ferrea.com) [www.ferreatv.com](http://www.ferreatv.com)

# ATL

## RACING FUEL CELLS

...the complete Racing Fuel Cell System Specialists.

FIA approved Safety Fuel Bladder Tanks, available in all FT3, FT3.5 and FT5 standards, can accommodate ALL road fuels and race fuels, ultra-lightweight bladder tanks available, ATL low cost Saver Cells, FIA Refuelling Equipment, In-Tank Collectors and 'Return-less' Fuel Systems, Fuel Pumps, Fuel Filters, Fuel Level Sensors, Foam Baffle....too much to list !



### ATL UK

Tel: +44 1908 351700  
[sales@atlltd.com](mailto:sales@atlltd.com)  
[www.atlltd.com](http://www.atlltd.com)

### ATL USA

Tel: +1 201 825 1400  
[atl@atlinc.com](mailto:atl@atlinc.com)  
[www.atlinc.com](http://www.atlinc.com)

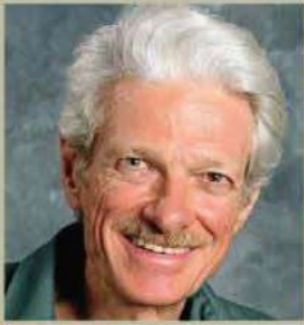

**FIRST PRINCIPLES**

Mark Ortiz Automotive is a chassis consulting service primarily serving oval track and road racers. Here Mark answers your chassis set-up and handling queries. If you have a question to put to him

**Email:** markortizauto@windstream.net

**Tel:** +1 704-933-8876

**Write:** Mark Ortiz  
155 Wankel Drive, Kannapolis  
NC 28083-8200, USA

**THIS MONTH:**

**Q Why would you have more negative camber on the front than on the rear?**

**A** In most cases because the mechanical properties of the suspension make it impossible to run as much negative rear

# Front negative

**Q** I have an MG Midget that runs on 8in wide slicks. The tyres used before (crossplies) are no longer available and those that now fit are radials. However, I have been told that if I run radials I will need more negative camber.

I notice that most classes, from Australian V8s to F1, run a lot of negative camber on the front, and an RX7 owner I know runs about -7 degrees for road racing. I also note that the

negative is only on the front and that the backs run flat or minimal negative. If this is required to get cornering grip with radials, why is it not also applied to the back?

As the backs always have (almost) zero camber, should this not give severe oversteer, as the front would seem to have much more grip than the back? How is it that the backs can grip with minimal negative but apparently the fronts cannot?

**A** In a fair number of cases, the reason for not having negative camber on the rear wheels, or having very little, is simply that it's not mechanically possible to run much negative on the rears because the rear of the car has beam axle suspension.

If the car does not have a full-floater axle (ie rear wheels that mount to hubs that turn on bearings running on snouts at the ends of the housing tubes, with axle shafts splined on both their inboard and outboard ends), but rather a conventional-style axle

(ie one where the wheel attaches to a flange on the end of the axle shaft, which itself has splines only at the inboard end), we can only get a small amount of negative camber. To achieve this, we have to bend the middle of the axle housing down, and then we are limited by friction and wear at the splines, or in some cases by an inability to insert the axle into the diff at all.

With a full-floater axle, we can do this and can also typically get half to three quarters of a degree [of negative] at the outboard ends, with ordinary straight

splines. Additionally, where legal, we can also obtain special axles with barrel-shaped splines, and special cambered snouts. But even with this exotic hardware, it is uncommon to see more than about two degrees.

With an independent rear suspension, it is, at least in theory, easy to get all the negative camber we want, although in production cars we may be limited by the adjustment range afforded by the stock hardware.

Negative camber is a mixed blessing, with any tyre. For cornering, what we really want

On a Midget, whether using radials or bias-ply tyres, some front negative will improve front cornering grip, but added front roll resistance is needed to eliminate oversteer

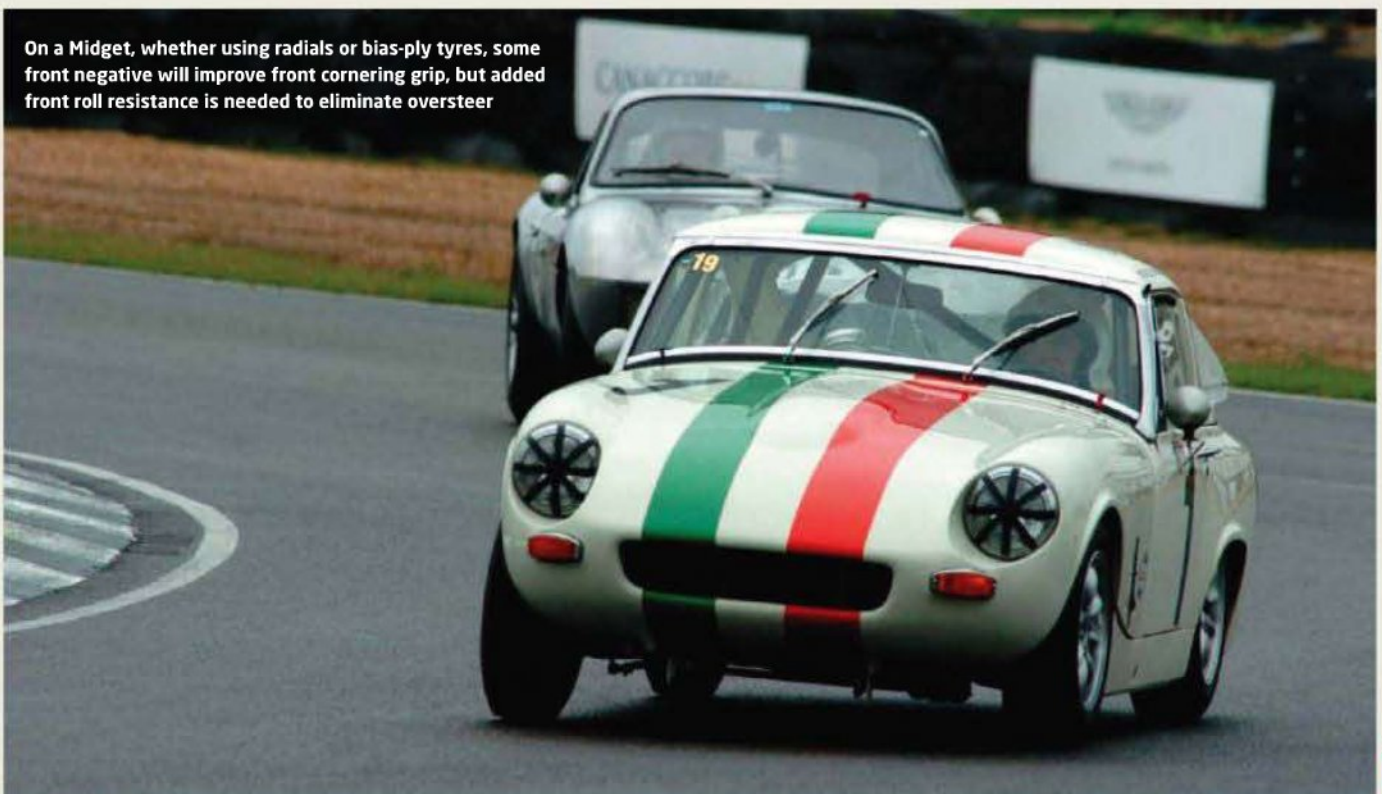





On a racecar with an independent rear suspension, you can have almost as much negative camber as you want, but the ideal is a small amount of inclination into the turns, with some added negative on the loaded, outside tyres in the corners

is some amount of inclination into the turn, meaning negative camber on the outside wheel and positive camber on the inside one. Exactly how much we want depends on the tyre, the rim width, the inflation pressure, the 'grippiness' of the road surface, and the normal force on the tyre.

The reason negative camber on both sides of the car is helpful is that, up to a point, it's worth giving up some cornering power on the inside tyre to get an increase on the outside tyre, since the outside tyre is more heavily loaded and consequently more important. The gain on the outside tyre is therefore greater than the loss on the inside one. Ordinarily, with passive suspension we can't get greater than 100 per cent camber recovery in roll, or even anything approaching 100 per cent, so we sacrifice inside tyre inclination to improve outside tyre inclination.

The more load transfer we have, the greater the gain on the outside tyre becomes, relative to the loss on the inside tyre. Taking an extreme case, if there is no load at all on the inside tyre, its camber doesn't matter at all.

But of course we don't just want lateral force from our

tyres, we need them to make longitudinal force as well. And for that, we want them straight up, with zero camber. So camber settings are always a compromise between lateral and longitudinal grip. At the front, running a lot of negative camber will help front cornering power up to a point, but

## “ camber settings are always a compromise between lateral and longitudinal grip ”

this will come at the expense of braking ability. At the rear, both braking and propulsion will be adversely affected (assuming RWD).

### EXTREME CAMBER

When we see really extreme static camber settings, that usually means the suspension's camber control properties are less than optimal. All Mazda RX7s have strut front ends, which have very poor camber recovery in roll when lowered for racing. The first version of the RX7 has a beam axle rear end so it isn't mechanically possible to get a lot of negative camber at the rear,

but the camber recovery in roll is much better than at the front. Later ones have a form of semi-trailing arm independent that can be set with quite a lot of static negative camber, but has better camber recovery in roll than the front suspension has.

When the front end has much

poorer camber control in roll than the rear, we can't assume that front wheel inclination is more favourable than rear when cornering, even on the outside front wheel, just from the static camber. It may be, or it may not be. And if the front end does have more favourable cornering camber than the rear, it does not necessarily follow that we will have oversteer. The camber does create a tendency toward oversteer in such a case, compared to a different camber picture, but other factors enter in, including front-to-rear roll resistance distribution, front-to-

rear weight distribution and the front-to-rear tyre size relationship.

If we do manage to achieve better cornering camber at the front than at the rear, that means we can use more spring and / or anti-roll bar at the front, and get balanced cornering with slightly greater limit adhesion, plus better ability to put power down while cornering, due to greater inside rear wheel loading. So we usually want to set the front camber for best front cornering power, provided we don't hurt braking too much. If the car is too loose, add front spring and / or bar. We could balance the cornering by taking front camber out instead, but that results in lower limit lateral acceleration, and poorer ability to put power down on exit.

Returning to the original question, with a Spridget we at least have a front end that benefits from being lowered, in terms of camber recovery in roll, rather than deteriorating with lowering as a strut suspension does. With radials or bias-ply tyres, give the front end as much negative camber as will improve front cornering grip, tempered by attention to braking, and then add front roll resistance as needed to eliminate any oversteer. 

See the **INTEGREX i-400S** in action at our  
**Power of Mazak** Open House event at Worcester.  
14 - 17<sup>TH</sup> JUNE 2011

# (MULTI-TASKING)<sup>M</sup>

Welcome to the new level  
of multi-tasking machining.

Complete every one of your  
machining operations from raw  
material to finished component in  
one hit, in one setup with the ultimate  
**DONE-IN-ONE** machines from Mazak.

Ergonomic, environmentally efficient and  
excellent value, the all new Integrex i series  
incorporates the very latest technologies,  
Mazak quality and total support.

Choose exponential growth for  
your **productivity**.

**ALL NEW INTEGREX i series**

Integrex i-300S shown



To see the full range of Integrex i series machines  
visit [www.mazak.eu](http://www.mazak.eu)

**Mazak**  
Your Partner for Innovation

# Investing more in technology

**Our technology centre is the most advanced in Europe.**

Extreme engineering and precision other performance cam manufacturers cannot match. Like a negative radius of -35mm, giving the fastest valve opening possible. You might not need such extreme technology but it's nice to know that all our camshafts and ancillaries have been developed by the best to be the best.

**Nº1**

**Kent Cams – the best in Europe:**

- No.1 for product development expertise
- The greatest performance increase of any single modification
- The widest range of camshaft ancillaries produced on site

**The most advanced technology:**

- Negative radius to -35mm
- CBN wheels with constant surface speed
- Multi-angle lobes with CNC dressing
- Marposs 3D C and Z axis position probe
- Microphonic wheel dressing
- Lotus Concept Valve Train software



**HIGH PERFORMANCE  
ENGINEERING**

[www.kentcams.com](http://www.kentcams.com)

Cams + Pulleys, Belts & Chains :: Valves & Valve Springs :: Performance Cam Kits & Valve Spring Kits :: Followers & Tappets



**Call us first...**

**Trident**  
Racing Supplies



Unit 31 Silverstone Circuit Towcester Northants NN12 8TN  
T: 01327 857822 F: 01327 858096 [www.tridentracing.co.uk](http://www.tridentracing.co.uk)

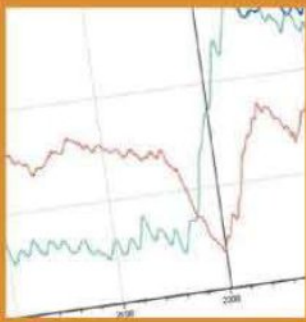

FIRST PRINCIPLES

Databytes gives insights to help you improve your data analysis skills each month as Cosworth's electronics engineers share tips and tweaks learned from years of experience with data systems. Plus we test your skills with a teaser each month.

To allow you to view the images at a larger size they can now be found at [www.racecar-engineering.com/databytes](http://www.racecar-engineering.com/databytes)

# Action stations

How remote data stations can help better analyse what the racecar you are engineering is doing



Figure 1: typical view of a live telemetry window. Tyre data is shown as raw numbers and bitfields indicate if there is a problem. Trends are then monitored using live graphs and summary tables

Computers have become an integral part of running almost any type of racecar and it is more than likely that you will find a laptop close to one even at the local drag strip or sprint track. As you progress up the racing ladder, the cars get more complex and the engineering starts to get more involved. This inevitably means data and even more computer involvement. At the top level of racing you will find that most teams will be running some form of data station for each of their cars and that a dedicated engineer is looking after this data station at all times. These data stations form an integral part of a garage network that centres around running the racecar. The data station will often have two

monitors, one of which will be connected to a server on a garage network and will hold data, video and set-up information for the team's vehicles. Another screen could then be connected to a laptop as a second monitor for the data engineer or race engineer. There are of course different

station will be carried out using laptops, as it will allow the engineers to take their work with them wherever they go.

The data station and garage network will generally have three ways of communicating with the on-board systems on the racecar. There will be the standard

## data stations form an integral part of a garage network

variations of data stations available, depending on how teams prefer to run their systems. There could, for example, be one large main screen with telemetry information for all vehicles, along with a TV feed. In most cases, the bulk of the work done at the data

download to a laptop using a direct cable connection between a laptop and the car. In some cases the download lead will have the ability to connect to a number of different systems on the car as it may be necessary to communicate with more than just the data

logger on the car. The next connection is the umbilical cord, which is connected to the car while it is sat in the garage. The umbilical allows the car to become an integral part of the garage network. This, in turn, allows the engineers to make changes to the on-board control systems and data loggers from the data

important ones - the data telemetry connection. Where permitted, teams can run a radio link to the car systems to allow them to view live various parameters on the car. These can include engine and drivetrain parameters, as well as tyre temperature and pressure information. Having this link

on another screen there can be older data from the same track or even from an earlier part of the race, which enables the team to easily monitor any trends or discrepancies. On a third screen, it's then possible to have a spreadsheet open to note any values of interest - maximums and minimums for example. It is, of course, possible to set the analysis software up to do this automatically if preferred.

Currently, the data stations are mostly used to monitor data at relatively low rates, as standard radio-telemetry systems do not have enough bandwidth to supply a great deal of information at high rates. With recent, and continuing, advances in communications technology, it is likely that in the near future the data station will serve as a much more involved tool in the analysis of racecar data as bandwidth increases allow. For example, it could allow for analysis of suspension movement at high frequency rates live, and receiving video signal from several sources onboard the race car at the same time.

## “ The data station really comes into its own when the car is on track during an endurance event ”

stations without actually going near the car. In many cases the area where the data stations are located is some distance away from the car or, in some cases, even in a separate office, in which case the umbilical cord is a necessary feature. It also allows the engineers to work on a car's systems without being in the way of any mechanical work being done.

The third connection is probably one of the most

allows the data engineers to monitor the health of the car, leaving the driver free to focus on navigating around the circuit and other drivers.

### LIVE STREAMING

The data station really comes into its own when the car is out on the track during an endurance event as it allows the engineer to have current data streaming live to the data station on one screen, while

## COSWORTH

Produced in association with  
**Cosworth**  
 Tel: +44 (0)1954 253600  
 Email: [ceenquiries@cosworth.com](mailto:ceenquiries@cosworth.com)  
 Website:  
[www.cosworth.com/motorsport](http://www.cosworth.com/motorsport)

## CHALLENGE

**Test your data analysis skills with this challenge set by the data engineers at Cosworth**



### Question:

This car was struggling with a lack of straight-line speed and was notably down on other competitors in the speed traps. What could have caused this?

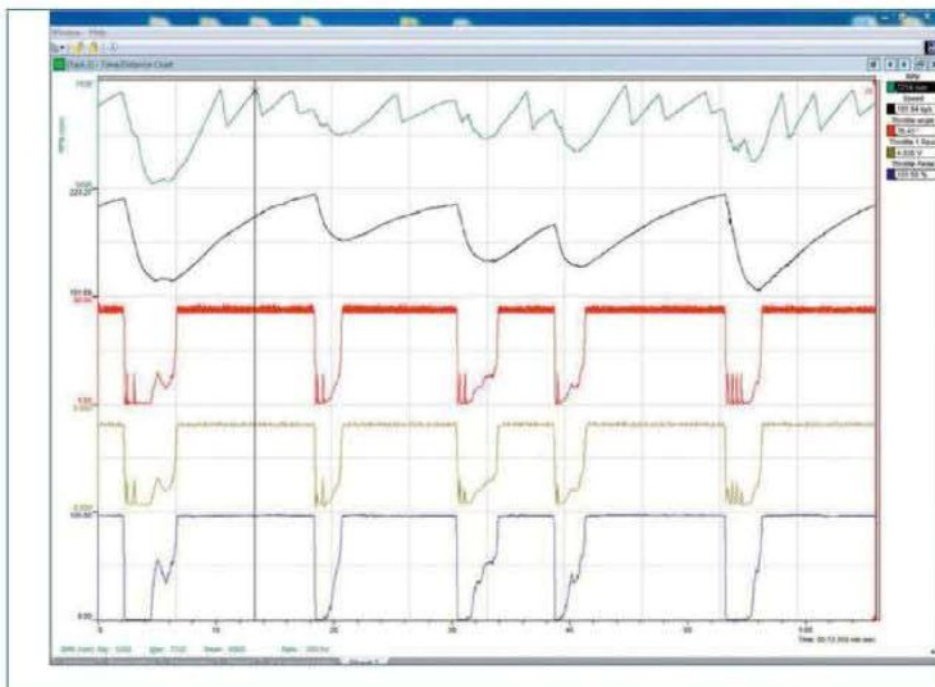

Find the answer online at: [www.racecar-engineering.com](http://www.racecar-engineering.com)

- Consultancy Design and construction
- Prototype Manufacture
- Project Management
- Le Mans Car Constructor
- FIA CN Sports Car Constructor
- Hillclimb Single Seat & Sports Cars
- High Performance Lotus Derivatives



Graham Hill Way | Cherry Holt Road | BOURNE | Lincolnshire | ENGLAND | PE10 9PJ  
 T. +44(0)1778 424838 | F. +44(0)1778 393032 | E. mike@pilbeamracing.co.uk

[www.pilbeamracing.co.uk](http://www.pilbeamracing.co.uk)

# Bosch, turning all corners into the home stretch

125 Years  Bosch  
 1886-2011



**Safely across the finish line:** ABS M4 from Bosch prevents wheel lock-up while maintaining controlled slip. All possible thanks to easily adjustable control settings specifically designed with competition in mind. This is where our experience lies – Bosch was the world's first automotive components supplier to launch ABS in to mass production in 1978. [www.bosch-motorsport.com/abs](http://www.bosch-motorsport.com/abs)



**BOSCH**  
 Invented for life

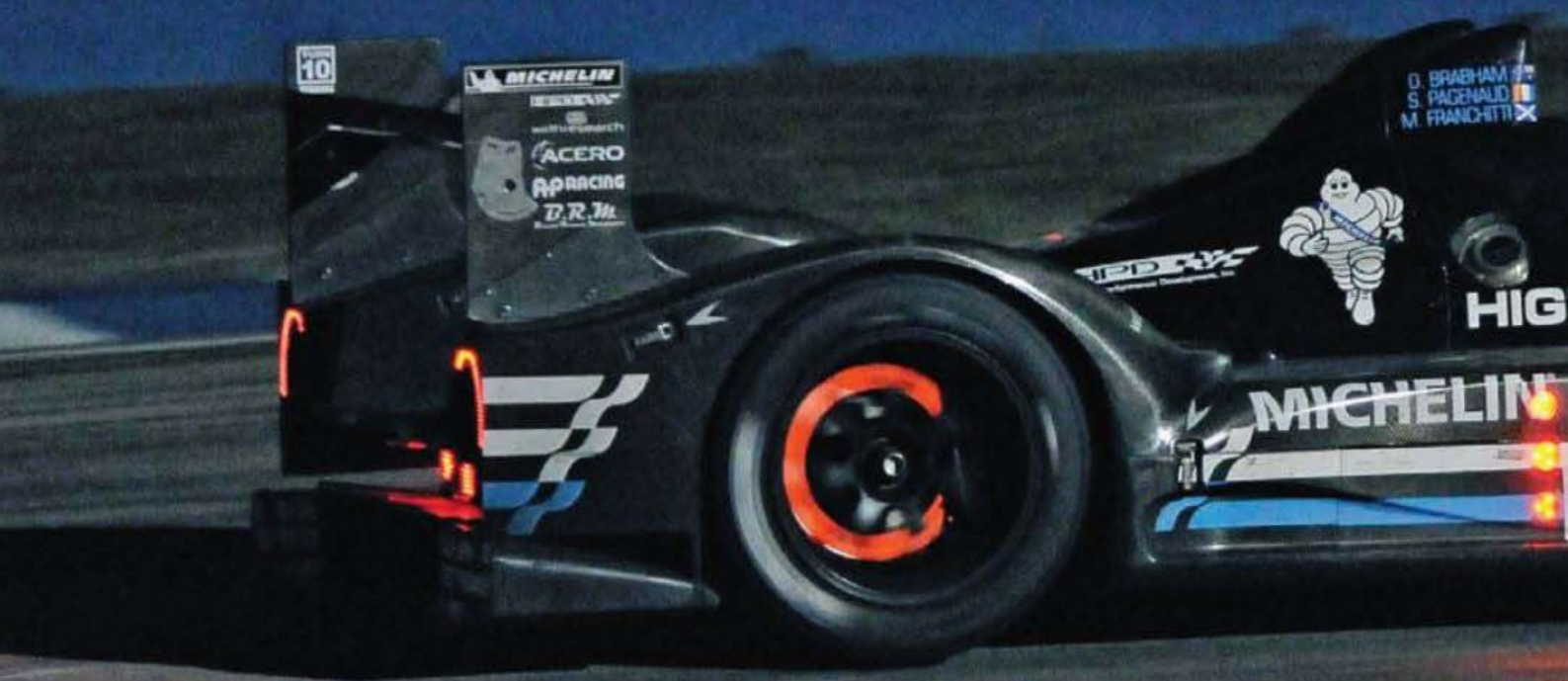

# Efficiency drive

HPD's 'new' LMP1 challenger uses lessons learnt from its past Prototypes to try and beat the diesels on a modest budget

**B**uilt from the same underpinnings as the company's fleet of championship-winning LMP2 cars, the HPD 01e represents almost everything Honda Performance Development (HPD) and Wirth Research have learned from its successful ARX programme.

The car features all of the best bits distilled into this 2011 ACO-spec Prototype, and from the moment it started its racing career at the Sebring 12 hours in March, it has delivered.

The use of the familiar ARX-01 chassis re-homologated as an HPD unit, after wholesale changes were made to the Courage LC 70/75 it was derived from, has allowed HPD and Wirth to avoid using the newly required engine cover fin.

BY MARSHALL PRUETT

The rest of the package, at least in spirit, conforms to the ACO's vision of a more relevant, less expensive and less environmentally harmful

**“ this car was designed for Le Mans ”**

Prototype. To achieve this three-pointed criterion, HPD assistant vice president, Stephen Eriksen, says it took a slight nudge from the French organisers to consider modifying their P2 car to try and take on the diesels. 'One of the things they've said after we were participating in Le Mans last year and did so well is, "This could be a P1 car. Why don't you consider

offering this as a P1 car?" I told them, "I'll think about that, that's interesting!"

Coming from the extremely expensive O2a project - a chassis built with all the latest technologies and construction

methods - HPD's limitations with the 01e were mostly financial. 'The O2a was literally a clean sheet and we were the first to adopt the wide tyre format and very low polar moment of inertia-style car,' Eriksen continued. 'But we knew from that experience just how expensive that approach is. It's really only appropriate to a full-on works programme, where

you've got the level of funding and the level of resources to be able to address a car that is that complex and that envelope expanding. If you look at the O2a, it has hydraulic power steering, it has wide front tyres, and all the complications that come out of that. It has ultra-expensive gears, an ultra-expensive gearbox and ultra-expensive suspension components. That is one approach.'

Although they did not know it at the time, the O2a - run for just one season before being shelved when Honda's bean counters pulled the plug on the LMP1 programme - would re-surface in 2011 and the lessons learnt with it would be applied to an 01e that had very little time or budget available.

'With the economic crisis that

“ a customer-friendly car that could be afforded by a team ”



3.4-litre V8 engine is run in HPD's 2008 Porsche battle-era spec, but updated with reliability improvements. In low-downforce Le Mans aero configuration, the efficiency and fuel consumption of the engine proved to be quite unprecedented



carry over things that were tried and proven, which is the engine and gearbox internals, the wiring and the shift systems and all of the control strategies, but upgrade to P1 wheels and tyres and to the latest and greatest aerodynamic tricks on the car, we could have a very capable car that would scare the diesels.

"We knew that, because some of the teams at some point will want to move from P2 to P1, if we didn't have a P1 product to offer, they would have to leave. So this was really intended to be a customer-friendly car that could be afforded by a team, rather than a car that was entirely financed by a works programme. The 01e is exactly that. It's got the dependable backbone of what won Le Mans by such a margin last year, which helps

hit, the edict came down from on high that we were going to cancel our works programme, so to speak, and doing a car of that approach was simply not financially feasible because we didn't have the backing. However, in the meantime, we started up customer programmes, which have been very successful in their first year. And having two teams - RML and Strakka - running our ARX chassis, I wanted to have a path for them to continue to be our customers and be our teams going forward into the future. What made sense to me was if we could do an update on the car,







Packaging the wider P1 tyres and wheels, and the associated cooling ducts, presented some issues, but lessons learnt from the P2 project paid off



Elements of the 02a-to-01d aero kit have been carried over to the 01e, including the flow conditioners used at the outer edges of the front wings

the reliability and dependability side of things, but then it's been upgraded and evolved to now be able to compete in the top class.'

**AERODYNAMICS**

Looking at the 01e's aerodynamics, the lineage is easy to trace. Designed as a low drag 'Le Mans' aero kit for the 02a that was never pressed into service, HPD and Wirth adapted the 02a's LM configuration to the 01d for

tall, protruding sections are in stark contrast to the low, minimal treatment found on the 01a through 01d. Gone are the large dive planes, replaced with an intricate single plane and turning vane arrangement, while in addition to changeable louvres atop the wheelarches, new, smaller louvres have been added on the vertical face of the nose's wheel inset.

'We took all the work and effort

**the small amount of fuel used was unbelievable**

its class-winning run at Le Mans in 2010.

Elements of the 02a-to-01d aero kit carried over to the 01e, including the flow conditioners used at the outer edges of the front wings (fenders). The only major change to the 01d's aerodynamics is found with the complete front wheelarch re-design that was necessary to accommodate the now standard wide Michelin front tyres. The

that had already been invested in the 02a investigation and applied it to our successful 01d chassis. That became the Le Mans-spec, low-downforce configuration, and the aerodynamics that were incorporated in that car allowed us to really unleash the efficiency of the engine to get some phenomenal fuel economy at Le Mans. Some of the stuff we've heard from the ACO is that the bar we set is unprecedented for a car

that went over 5000kms, and that the small amount of fuel used was unbelievable.'

Accommodations were made at the front of the 01e to fit the larger wheels but, once again, knowledge of packaging wider wheels and tyres and the placement of the larger brake cooling system were drawn directly from the 02a. Wirth's team is also said to have recovered most of the aerodynamic losses caused by the increased frontal area.

Mechanically, with the exception of the wide front tyre fitment, the 01e looks no different than the 01d. Its bodywork was re-crafted for P1, but the rest of the car is pure P2, with the updated, 3.4-litre V8 engine drawing from the ALMS' golden era of furious Acura vs Porsche battles.

'From a performance standpoint, essentially, when you look at the restrictor size, what we did is we went back to 2008,' Eriksen explained. 'So what we dug up was our Porsche battle-era, 2008-spec engine configurations, and brought those performance ideas forward to 2011. But then we also took into account the reliability improvements that we'd made over the period since then. Combine them together and that's the spec we ran at Sebring.'

**VALUABLE LESSONS**

HPD learned a number of valuable lessons at Le Mans last year - specifically in improving ancillary engine components such as braces, belts and other vibration-prone items. The merging of HPD's 02a project, the proven ARX-01 platform and the endurance lessons gained at Le Mans all fed into the 01e, making an incredible run to second overall at the 2011 12 Hours of Sebring.

The decision to work from known components and concepts allowed HPD and Wirth to bring the car to market in just over four months, after final approval was given in November 2010. The brutally tight deadline saw the 01e delivered just days before the week of activities began at the gruelling central Florida track and, with almost zero miles on the car,

**TECH SPEC**

**Class:** LMP1 (2010/2011)

**Chassis:** Courage LC75 carbon fibre monocoque

**Engine:** Honda Performance Development LM-V8 N/A, fuel-injected, aluminum alloy cylinder block, Dual overhead camshaft, 4 valves per cylinder  
Capacity: 3,397cc  
Bore: 93mm  
Stroke: 62.5mm

**Transmission:** Hewland six speed sequential gearbox

**Clutch:** Carbon, pull type triple plate

**Brakes:** Carbon/Carbon

**Suspension:** Double wishbone with push rod actuated dampers front and rear  
Dampers: Dynamic DSSV

**Steering:** Power assisted rack-and-pinion

**Dimensions:**  
Length: 4620mm  
Width: 2000mm  
Height: 1020mm  
Wheelbase: 2870mm

Highcroft Racing managed not only to compete with, but pass Peugeot's new 908 and Audi's R15+.

The potential shown with the 01e has everyone at HPD, Wirth and Highcroft salivating at the thought of bringing the car to Le Mans for a proper 24-hour battle with the diesel titans. How the chassis will fare on the long straights - just the place Wirth's aerodynamics are meant to pay off - will be fascinating to watch, if the budget to ship and race the car can be found.

'I have every hope it will reach Le Mans, and we are pulling out all the stops with everybody that we can think of to try to find a way to get there,' says Eriksen, 'because this car was designed for Le Mans.'

'Highcroft has been given an invitation, so that's the first hurdle, and we've got a car that is fast and reliable. We stayed after the Sebring race and did a further 12-hour run, so got up to our 24-hour race distance without a hitch, despite the car being only a week old.

'So we've now taken that first step so I'm very hopeful. I think it'll be a really fun opportunity to get that car out there and mix it up again.'



# HOW TO BUILD A F1 CAR WITHIN FIVE MONTHS

On Pole at Lotus Racing.



Visit [www.capricorngroup.net](http://www.capricorngroup.net) for the complete story.

 **capricorn**  
A U T O M O T I V E



# One Company. One Solution

PMI Europe B.V. is located in The Netherlands and the European hub of Performance Motorsports Inc of the USA which owns the brands shown below. PMI Europe B.V also distributes ARP, Cometic and Carrillo to serve you as a one stop supplier.

New!



Innovate Motorsports Diagnostic equipment (AFR-OBD-II)



K1 Cranks & Rods



ARP Bolts & Studs



Innovate Motorsports



Cometic Gaskets



Wiseco Forged Pistons



Carrillo Rods



PMI Europe BV  
Pesetaweg 32  
2153 PJ Nieuw Vennep  
The Netherlands

Tel: +31 (0) 252 680437  
Fax: +31 (0) 252 684643  
Email: info@pmi-europe.nl  
Web: www.pmi-europe.nl



# OBR

Control Systems

WHY FOLLOW WHEN YOU CAN..... LEAD

# 1<sup>ST</sup> 2<sup>ND</sup> 3<sup>RD</sup>

## IN 2010 LE MANS 24 HOURS

OBR technology was also used by cars finishing 4th, 7th and 9th, taking victory in the unofficial LMP1 Petrol class as well as 2nd and 4th in LMP2.



Specialising in engine / power management systems and a complete range of data logging, displays, sensors, actuators and wiring

Ole Buht Racing (UK) Ltd is a world leader in the supply of motorsport electronics. Our range of innovative products are used in the world's most demanding environments ensuring performance and reliability.

# WWW.OBR.UK.COM

# Workhorse power

How Honda turned its production V6 into an endurance racing engine within the ACO's strict 75,000 euro cost cap

BY F LAWRENCE BUTCHER

2011 has seen a seismic shift in the regulations governing cars that compete in the Le Mans Prototype 2 (LMP2) class at Le Mans, as well as in the LMS and ILMC championships. With the ACO's (Automobile Club de l'Ouest) intention being to return the category to a true privateer class and prevent manufacturer domination, the new regulations placed a cost cap on chassis and engine packages, as well as specifying that a production-based engine must be used, with a total cost of no more than 75,000 euros.

One of the first companies to step up to the mark was Honda Performance Developments (HPD), who unveiled its new, 2011-compliant engine at the 2010 Le Mans 24 Hours. Based around the 2.8-litre unit found in vehicles as diverse as the Accord family saloon and luxury Acura coupés, the engine is a true mass production unit, and one of the workhorses of Honda's range.

Stephen Eriksen, vice president at HPD, explains how the new engine came about: 'We have been pretty closely involved with the ACO over the years and they have been very up front

**↳ a joint project between the production engineers and the race engineers ↳**

about their rules direction for some time, and we have been following that closely. When they suggested they wanted to go towards a production-based engine we started to look at what we had in our line up that

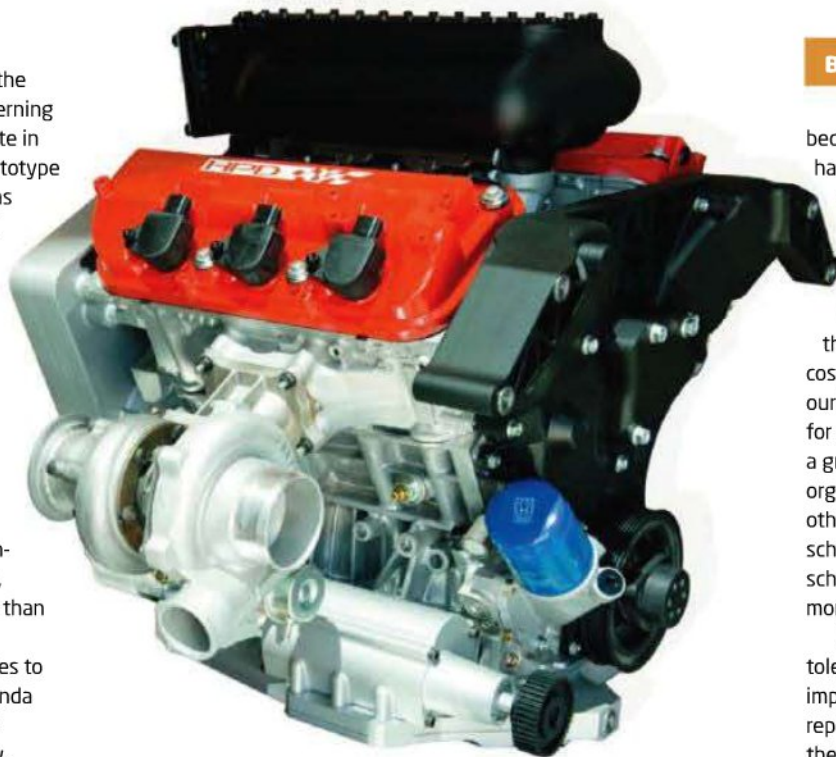

**A true world engine, Honda's production V6 is found in a diverse range of models, from family saloons to luxury coupés**

would be applicable. The one we settled on was a V6 that you can find all over the world. It has an architecture that has been around for a number of years, originally starting as a 2.7-litre and then in various forms up to 3.7-litres.'

Initially, the team had hoped to use the engine in naturally

aspirated form, but the ACO's focus on a low-price (in racing terms) powerplant meant development costs had to kept under tight control. To remain financially viable, the most cost-effective route to achieving

the power and reliability required to be competitive was to go with forced induction, removing at a stroke the need to re-engineer all of the reciprocating parts.

#### DEGREE OF HARMONY

The whole operation surrounding the development of the engine also differed from the usual 'Skunk Works' operations, where the motorsport arm of a manufacturer is separated completely from the mainstream production departments. In the case of HPD, the new engine programme combined teams from both departments, the two groups of engineers finding a useful degree of harmony, with benefits for both parties. Eriksen is keen to point out the advantages of this approach: 'It is pretty interesting

because it is the first time we have done a joint project between the production engineers and the race engineers, so it was a great learning opportunity. The production guys bring their knowledge, not only of the base engine, but how to trim costs down. This, combined with our knowledge of what is required for racing applications, provided a great opportunity for the two organisations to learn from each other. We work on a much shorter schedule than a production schedule and they work with much more constrained cost targets.'

Modern production car tolerances are constantly improving and Honda has a reputation for building some of the most precisely engineered engines on the market. The aim with the LMP engine was to use mainstream production methods to produce racecar quality parts, such as the crankshaft, which is a bespoke item tailored to the demands of an endurance race engine. The effect on end unit cost of this component alone is considerable - where a bespoke billet crank could cost upwards of \$5000, a similar item made using mass production techniques may ultimately cost just a few hundred dollars. A number of other reciprocating components have also been revised, though HPD has used as many stock production parts as possible to keep costs down. The valvetrain, for example, is based on standard components, although some have been modified to improve durability.

To confirm the suitability of these parts, a large amount of dyno work was completed, as Eriksen explains: 'We started out with a mule engine and this gave



The Honda engine was never intended to serve as a fully stressed member, so to solve the problem an external structure was built, which encases the engine and offers the amount of rigidity needed

us confidence in the power levels that could be achieved. Then we began to make the dyno engines closer to what the final iteration would be. [The race engine] is capable of much more power than the P2 requirements, and this is definitely confidence inspiring.'

**STRESS MANAGEMENT**

One of the biggest problems with using a production engine related to its potential for use as a structural component. The majority of LMP cars use the engine as a stressed member – a detail that is factored in at the design stage. Unsurprisingly, the Honda road car unit was never intended to be stressed, which presented a challenge to the HPD engineers. They first set

about investigating whether the unit could be used in a stressed or semi-stressed role. This was new territory for HPD: 'When you look at the engine you can see that we have built a kind of

**▮▮ The aim was to use mainstream production methods to produce racecar quality parts ▮▮**

structure which envelops the base engine and provides it with a large degree of rigidity. We have done all of the torsional testing to verify that this installation will work well and can actually work as a fully stressed member, so we envision that this will be a good

engine to use in other applications beyond LMP2,' explains Eriksen.

HPD also looked at using the standard production ECU as a basis for the new engine's control system, as well as

replacement systems from other manufacturers. Ultimately, though, the engineers decided that an in house-developed system would provide the best balance between cost and performance, and settled on that developed by HPD for the 1.5-litre

Honda engine used in SCCA Formula Ford competition.

Naturally, Eriksen is hopeful the new engine will ultimately prove to be profitable too, even within the ACO's 75,000 euro cost cap: 'Initially, we will probably have one cost structure as people test the water but then, as more people adopt it, you have some economies of scale that can be applied. There will also be a lease and purchase option available. Traditionally, HPD has only used leases because we think it provides the best support for the customer, but we are open to teams wanting to do something different.' Beyond the realms of LMP competition, HPD is keen to see the motor used in other series, with the basic architecture providing the core for various roles.

An increase in air restrictor size, by a massive 1.2mm at the Le Mans test day improved the performance of the RML-run HPD following its European debut at Paul Ricard and teams are still hoping for more to better balance turbo engines. This may not be a pure race engine but, in Eriksen's opinion, it has the soul of one. 'The best part of this project was that the guys who worked on the programme put their heart and soul into it, and it has worked out.'

With development ongoing, the HPD V6 could lead the way for the new generation of production-based LMP engines. 

**LIVING WITH THE NEW ENGINE**

▾ UK-based Strakka Racing is one of the first teams to use the new HPD engine, running it in its HPD 01d chassis. Having previously run the purpose built, 3.4-litre, naturally aspirated, racing V8, the change to the smaller forced induction unit necessitated a complete re-work of the car. Pierce Phillips, team manager at Strakka: 'The change has been huge. The packaging is now much tighter, and the heat rejection from this engine is quite high, so it now runs twin radiators, twin oil coolers, twin gearbox coolers and twin intercoolers (whereas the V8 ran

a single water radiator and oil cooler on one side of the car). It is very busy package and anything but a straightforward installation. Obviously, the basic engine is much heavier than the pure race

**▮▮ heat rejection from this engine is quite high ▮▮**

engine, which is not ideal, but, with the change in regulations and the increase in minimum weight, it is quite useful for maintaining the weight balance of the car. The torque is much greater and that has required a

complete re-think of the transmission, from gear ratios to clutch. There is also a big aero change, due to the additional cooling demands, but Wirth Research has done a fantastic job

on the package. The first time the engine ran in 2011 spec was in our car for a two-day test and it was faultless.'

The dynamics of the new engine have also necessitated a change of approach from the

drivers, with power and torque delivery requiring a different style of driving from Strakka's Nick Leventis: 'Driving the turbo is obviously very different to the old naturally aspirated engine, and at our last test we had not got the mapping quite right. When we got the car in 2010 it was at the end of a five-year development cycle and was running as well as it possibly could. This time we were starting from scratch and it is a big challenge, but the result we had after testing was great, with a nicely balanced car and good power delivery.'



Pall Corporation

**FHS**  
MOTOR RACING

# The 'Preferred' Choice in Filtration

## Now available from stock at FHS Motor Racing

### The C-Thru Separator Tramp Oil Removal Unit

Removes free and dispersed tramp oil from machine tool coolants and parts washing fluids

- Improve machining performance
- Reduce machine maintenance
- Extend fluid service life
- Reduce fluid disposal



Pall products are available for all your fluid management requirements



Hydraulic and Lubrication Filters



Fluid Monitoring Equipment



Last Chance Filters



*Filtration. Separation. Solution.<sup>SM</sup>*

**Contact FHS Motor Racing for more information and product supply:**

656 Ajax Avenue, Slough, Berkshire SL1 4BG

Tel: +44 (0) 1753 513080 Fax: +44 (0) 1753 513099

email: [info@fhsracing.co.uk](mailto:info@fhsracing.co.uk) [www.fhsracing.co.uk](http://www.fhsracing.co.uk)



# The original CONNECTORS

METICULOUSLY ENGINEERED TO CONNECT

**ADEL WIGGINS** Flexible Tube Connectors

## THE POWER TO SECURE

Stay connected with Adel Wiggins Flexible Tube Connectors! The difference between winning and losing is in the connection. Do not sacrifice a win to a simple hose blowout or burst. This occurs when conventional hose clamps or barbs fail to secure the hose located between the connections or components. Adel Wiggins Flexible Tube Connectors eliminate these failures. This is why so many professional racers today confide in them.

## THE POWER OF EFFICIENCY

Adel Wiggins Flexible Tube Connectors are very efficient when it comes down to valuable time sensitive installation or removal. They can be quickly removed and installed with only one hand, whether they are being used with tubing or hose. The locking latch design eliminates troublesome and time-consuming installation of safety-wire or the necessity of tools to make the connection. The electrical bonding feature eliminates the external clamps, fasteners and jumper wire required in some applications. The W900 series minimizes weight and unit cost, while retaining the proven performance and reliability of other WIG-O-FLEX connectors.

## GET CONNECTED!

Adel Wiggins Flexible Tube Connectors are offered standard in lightweight aluminum and are available in stainless steel or titanium upon special order. They feature an operating temperature range from -120° F to 800° F and are able to withstand boost and pressure levels in excess of 125 PSI.

## CONNECTOR APPLICATIONS:

- Full Engine
- Radiator
- Intercooler
- Oil Cooler
- Turbo & Blower
- Throttle Body



GET CONNECTED!

FULL ENGINE APPLICATIONS



# FCP

Fluid Control Products, Inc.

Australia: Rocket Industries 02 8825 1900 | England: Goodridge UK 01392 369090 • BMRS 0175 355 3610 • Earts UK 0132 785 8221 Toll Free in NA: 800-541-2345  
 Germany: Goodridge Deutschland 06321 60148 • Krontec 09401 52530 | Italy: Technauto SRL 02 738 8773 Worldwide: 217-324-3737  
 Japan: SIFO Corporation 03 5420 4154 | New Zealand: Turbo Vehicles Ltd. 09 525 6696 www.fluidcontrol.net

**PRO-SHIFT**  
electronic gearshift

Championship Winning  
**Semi-Automatic Electronic Gearshifters**  
for Racecars & Superbikes

Now available  
This superfast and highly sophisticated  
**Gearshifting PS3 Paddleshift System** suitable  
for **Racecars and Superbikes** with over 170  
adjustable parameters

**PS3 System**  
Offering Fully Closed Loop Gearshifting for  
both Racecars and Superbikes

**Auto-Blip & Downshift Lockout**  
For clutchless downshifts plus engine over-rev protection

**Graduated Ignition Cuts**  
Individually programmable for all gears

**Auto Upshift Facility**  
Max power upshifting at full throttle...

For more information:  
email: [info@proshift.com](mailto:info@proshift.com)  
telephone: +44 (0)1332 668100

[www.proshift.com](http://www.proshift.com)

**CARTEK**  
MOTORSPORT SAFETY PRODUCTS

**SOLID STATE BATTERY ISOLATORS**  
Small. Safe. Reliable. Used by professionals

GT Rally Formula

Developed specifically for motorsport use the Solid State Battery Isolator from **CARTEK** is a major advance in the safety and reliability of race cars.

Fully electronic with no moving parts, and cemented into an aluminium shell, makes this system highly resistant to shock, vibration, moisture and dirt.

Using the latest MOSFET technology this system provides safe, spark-free isolation of the vehicle's battery and engine electrics in accordance with FIA and MSA regulations.

**NEW FIA Rain Light**

**CARTEK** now produce the smallest and lightest rain light that meets the latest FIA specification for size, intensity and viewing angle.  
Future Proof.

Solid, robust construction with 2x M6 studs.  
Can be mounted vertically or horizontally.  
Available static or 3Hz flashing.  
56mm x 90mm x 15mm, 153g, 0.2Amps, 200cd  
FIA Homologation No: MSA/RWL/33/10

[www.CARTEKMOTORSPORT.com](http://www.CARTEKMOTORSPORT.com)  
**CARTEK AUTOMOTIVE ELECTRONICS LTD**  
 Tel: +44(0)2380 637600 Email: [info@cartekmotorsport.com](mailto:info@cartekmotorsport.com)

# THE DESIGNERS

## MIKE PILBEAM



“ I thought I'd like to explore the theoretical aspects of it at least, and the only way I could think of doing so was to build a car ”

Mike Pilbeam might be best known for his successful hillclimb cars, but there's far more to his motorsport CV than just rapid ascenders

BY MIKE BRESLIN

Think Pilbeam, think hillclimbing. And yet there is so much more to the man than designing cars that go up narrow British country lanes, very quickly.

How many designers have worked on projects as diverse as the BRM four-wheel drive F1 car and the Lotus gas turbine, as well as a wide range of single seaters, sportscars, touring cars and even rally cars? Oh, and while we're at it, how many have got to name their own street?

Mike Pilbeam has. In fact, he's pretty much done it all - and we'll come back to the street naming later. But it all started off with numbers, which is fitting, because Pilbeam's approach to any project is to make sure the numbers are right first. 'I always try to design from first principles, to understand what is necessary to make a car both fast and reliable, and to do that you have to understand the

“ Pilbeam's approach to any project is to make sure the numbers are right first ”

maths and the laws of physics - they don't change, and are not likely to in a hurry.'

It was actually while he was studying for a degree in mathematics at Bristol in the late 1950s that Pilbeam first came into contact with motorsport, taking a trip to Silverstone to watch an F1 race. 'I thought, "oh this is good stuff". But, to be honest, I knew nothing about engineering. Then, when I left uni, I thought I'd like to explore the theoretical aspects of it at least, and the only way I could think of doing so was to build a car.'

Like many who went on to greater things in the world of motorsport, Pilbeam's first racecar was built for the 1172 formula in 1959, and he went on to build a version of it for a customer, which won a number of races. But it was his talent with numbers that opened the door to Formula 1 in 1963. 'I'd realised that rather than being a pure mathematician and working in infinite numbers and all that, I wanted to do something in motorsport. So I wrote to a

number of companies, including BRM, and eventually I was offered a job. I was there under Tony Rudd, who in his book refers to me as a 'number cruncher', and I suppose that's what I was at that time. I was a stress engineer to begin with, which involved doing calculations on engine and chassis parts. Tony Rudd's wording of it was that I was there to make sure things didn't break. But I like to think there's a bit more to it than that. It was making sure they were also as light as they could be.'

### EXPERIMENTAL PROJECT

A year after his arrival at BRM, Pilbeam was given the chance to design his own Formula 1 car, but the P67 was something extraordinary. 'Tony wanted to do it as an experimental project. They wanted to see if four-wheel drive was a good idea for when the 3.0-litre formula came along. He said there was no money for it, but you can have a bloke in

the workshop to help, and any bits that anyone else doesn't want, you can use! Apart from the transmission, of course, and we spent quite a bit of time with Ferguson's doing that.'

As Pilbeam says, the idea behind the car was to see if 4WD might work in F1, but ultimately it just didn't quite add up: 'In order to get the balance of handling right you needed to have quite a lot of bias on the rear drive, and you ended up with about 30-70 torque split front to rear, at least with the tyres that existed then. We couldn't get any better than that, which means you're not making as much use of the front drive as you'd like to. It was quite good, but it lost power and it was heavy, and that overcame the positive performance aspects. We decided it was a nice idea, but we weren't going to do it.'

But the P67 was not the only groundbreaking work he was involved in at BRM, where as early as 1965 they were using data logging. 'I'm pretty sure we were the first to use data logging on a





Pilbeam's first racecar was built in 1959 for the 1172 formula. The car pictured here is the R3, the 1961 replacement for that original design



Where Pilbeam really excelled was in the construction of British hillclimbers. This is his eponymous company's hugely successful MP88



Pilbeam's most recent chassis, the MP97, again uses a carbon monocoque and is a development of the MP87. It's a regular in the Top 12 Run Offs

car. It ran off a 12v box battery, and there was a small box with the paper enclosed in it, then it had suspension sensors just like you have now - like a miniature telescopic damper that moves as the wheels go up and down. For its day it was very advanced and it did just the same things as you do now, though not quite as much. It measured suspension travel, steering angle, g forces, acceleration, all of those things, and it was developed by me and a guy from the electronics department of [BRM owner] Rubery Owen.

'There weren't any computers, and that was the problem with it. It printed out on a three-inch wide strip of paper, all the traces like you see on a computer screen now, but you couldn't record it to a computer and manipulate it. It could do about 20 minutes on track, I think. The only thing is you ended up with 200 yards of paper and you had to go over it with a ruler measuring and making a note of everything.'

In 1967 Pilbeam moved on to Lotus, where he worked under

Maurice Philippe and Lotus founder and boss Colin Chapman, who he remembers as 'a brilliant man, but very demanding. He expected so much of everybody, there was more than one time when the team spent several days without sleep.'

**LAUGHING GAS**

At Lotus, Pilbeam worked on a number of cars, but one that sticks in his mind is the Lotus 56 gas turbine car, originally developed for Indy but then used

**I'm pretty sure we were the first to use data logging on a car**

in F1 in 1971 as the 56b. 'The gas turbine had loads of power [the Pratt & Whitney turbine developed 600bhp, against around 400bhp for a DFV back then] but it suffered partly from not having engine braking, but more from throttle lag, which we never entirely got rid of. So the

driver had to apply the brakes and the throttle at the same time to try and compensate for that, which used to mean even harder work for the brakes.'

Perhaps unsurprisingly, he remembers some spectacular tests at Hethel with glee: 'It just used to sit there and whirr away as it went off the line. We over-fuelled it to try and get rid of the throttle lag, so there was a load of extra fuel flying around - and a wonderful big orange ball of flame would come out the back.'

Then he came back, and there was a quarter-scale drawing of the 72. He said: "that's the idea, now make it work." Which we did. It was his concept in the first place, but there was still a lot of work to get it done.'

And it was not a simple task: 'It was a very complex thing to build, and it was difficult to fit the fuel tanks. It was not terribly practical in that way. Overall, it was a fantastic car, but when it first came out, under Chapman's direction - because I might have done the calculations but he was the boss - it was very light and, to be honest, very delicate. The whole monocoque had to be beefed up substantially after the first chassis was made.'

**ADVANCED AERO**

By 1972 Pilbeam was back at BRM, via a stint at Surtees, but now in charge of chassis design, first developing the P160 into a competitive proposition (P160d), and then designing the P201 from scratch for the '74 season, a car that was triangular in shape



**Top:** whilst working at Lotus, Pilbeam was involved with the 56 and 56b, the latter of which (shown here) made its F1 debut in 1971. The earlier gas turbine-powered 56 was developed for Indy, but never lived up to expectations  
**Above:** 1977 F1 design, the LEC, which Pilbeam himself refers to as the R21  
**Above right:** a 1988 design, the MP84 Le Mans SR2 / LMP675 Sports Racer  
**Right:** Ciaran Pilbeam, Mike's son, is following in his father's footsteps - a gifted mathematician himself, he currently works in Formula 1 as Mark Webber's race engineer at Red Bull

and certainly aerodynamically advanced for its time: 'The shape was derived from wind tunnel tests, where we found that when a car is running at an angle as it goes around a corner, due to the slip angles of the tyres it yaws by a few degrees. So, in effect, the air isn't hitting it straight on, it's hitting it at an angle. What was happening to cars like the P160, for instance, is that you would get a pressure build up beneath the curved side. So the triangular side was meant to build up air pressure on the top surfaces, which it did reasonably well.'

Pilbeam was sad to see the end of BRM in F1 - and remains based in Bourne, Lincolnshire, today, though the old BRM factory is now a bus garage, he tells us - but it was at least the catalyst for him setting up on his own company, first as a consultant -

designing the Wheatcroft F2 cars amongst others - and then as a full-blown constructor. But he wasn't done with F1 just yet, and in 1977 came the LEC.

#### COOL RUNNING

LEC was a privateer effort for owner / driver David Purley, built at his family's refrigerator factory on the south coast of England. 'It was a difficult project in that I had an office here [in Bourne] and the guys building it were in Bognor. You didn't have computers and fax machines to send drawings, so it was all telephones or post or going down there. Also, the guys who built it came from the LEC factory and, with possibly one exception, they had never seen a race car before.'

But surely a fridge factory can at least sort the cooling? 'I did talk to them about that aspect of it,

and I asked them that since they had the technical knowledge, could they help us design the cooling. They said they could help, and they came back to me and said I wanted a radiator that was about four foot square!

The LEC CRP1 used the same aero principles as the P201, but otherwise Pilbeam says he simply tried to make an uncomplicated and reliable car. It actually led a race, in the wet at Zolder, but it's also remembered for the huge shunt Purley suffered at Silverstone - a 179.8g impact the former paratrooper was lucky to survive. The car decelerated from 108mph to zero in just 26 inches.

'David Purley was a hell of a bloke. A very brave man. He was an extremely quick driver and totally fearless. On the morning of the accident he had had a small fire and it had been put



out with an extinguisher. They'd cleaned it out but some of the extinguisher powder must have been left in there, and this got in the throttle slides. I think Dave thought the brakes had failed, but what had happened was the throttle had stuck open. Had he realised perhaps he might have been able to switch it off in time, but it ended up in a huge accident. It was awful. He was quite badly injured [he went on to race again and died in a stunt plane crash in 1985] but I think everybody

Pilbeam's most recent (2004) Le Mans car, the carbon fibre-tubbed MP93



Above: spectacular shot of the triangular-shaped 1974 BRM 201 (right). Designed in a wind tunnel, the car was aerodynamically very advanced for its time

agreed that the way the chassis stood up was pretty good:

**RUN TO THE HILLS**

It's possibly partly because of this accident that Pilbeam has become well known for the quality of the crash structures in his racecars, and he freely admits it 'focused the mind', something for which many a hillclimb driver should be thankful, for it was at about this time that his hill racers were beginning to make an impression.

Pilbeam's first hillclimb project was a 2.0-litre Brabham BT38 owned by Alistair Douglas-Osborn in 1975, for which he re-designed the bodywork, changed the nose and sorted the suspension. In fact, the first hillclimber to bear the Pilbeam name was the same car, though greatly modified and now packing a Cosworth DFV, which was numbered R22, the company switching to its familiar 'MP' prefix soon after.

Pilbeams went on to clinch 17 British titles on the hills and, even now when there are far fewer of them - the latest offering is the carbon monocoque MP97 - they will regularly make the Top 12 Run Off. So it's understandable that he is best known for his hillclimb cars. 'I have to say that most people I bump into, their first reaction is, "oh, you build hillclimb cars don't you?" But I really would like to be known as a Le Mans car builder. To me, there are only two areas now where you've got design freedom - one is hillclimbing, the other is Sportscars.'



Able to turn his hand to all motorsport disciplines, in 1998 Pilbeam developed a Hyundai coupe rally car, designated MP83

Of the latter, Pilbeam says his first LMP2 car, the MP93, was one of the most difficult challenges he has yet undertaken. 'When I did that I had built a few Endurance Sports Racers, SR2 and 675 cars, but that first LMP2 car with a carbon chassis was a very serious undertaking,

**I would really like to be known as a Le Mans car builder**

both technically and financially. We stuck our neck out because when I decided to do it we had no customers, but it worked out alright for us. We would have liked to have gone on longer with that and done a few more.'

LMP2 is still a possibility for Pilbeam - his cars have been out of the fray since 2007 - and he is interested in producing something for the new cost-capped regulations, if some customers come along. 'We

are certainly thinking about it. We've got new ideas, especially in the aerodynamics. I think we have found ways in which we can get appreciable increases in downforce without drag increase, but with just a slight trade off with c of g. We've done some analysis on that and we think it's viable.'

Note the word 'analysis', for it's the bedrock of the Pilbeam method. Whatever the project, the approach is the same. 'It is always to work out what's important, whether it's a hillclimber, Le Mans car or F1, to make them work. These days we can analyse that better than we used to. But you have to make your mind up fairly early on, on the fundamentals of what makes the car work. Someone once said that once it gets on the computer, the design

should be done [Pilbeam designs in 2D and 3D CAD, but also does some 'bad sketches'], but you have to think it out first.'

**OUT OF THE ORDINARY**

It's perhaps because he always starts from fundamentals, making sure the numbers are right, that he has never been afraid to take on projects that are out of the ordinary. And alongside the many Formula cars - all the numbers from 1 to 4, with 5000, Renault

and Atlantic thrown in - Pilbeam has designed and built Touring Cars (the MSD-run BTCC Honda Accords in the '90s, for instance) and rally cars (including a Nissan Dakar project in 2002) and there are even quite a few road car projects - particularly with Lotus in recent years - that have boasted the MP prefix.

So the MP numbers continue to get bigger, up to MP99 now, which is fitting for a mathematician. But he is not the only racing mathematician in the Pilbeam family as there is also son Ciaran, Mark Webber's race engineer at Red Bull. Mike is rather proud of his son - as much for his first in mathematics from Cambridge and his Phd from Cranfield as his lofty perch on the F1 pit wall.

Mike Pilbeam is 73 now, but shows no signs of slowing down or retiring, and his eponymous company has plenty of ongoing projects in motorsport, including its VdeV Sportscar, plus the general automotive and tuning sector to work on, all from premises close to where this remarkable career started.

Which brings us to that street name, 'Graham Hill Way', in honour of a slightly more famous former BRM employee: 'When we built our first factory we also built the road, so I got to name it,' explains Pilbeam.

Shame he's so modest then, because 'Pilbeam Drive' has a nice ring to it, and he's surely done enough in motorsport to deserve the accolade. Oh, and it wouldn't have to be on a hill, either. 

# WE MAKE, YOU RACE!

## WINDFORM ADDITIVE MFG:

CAR AERODYNAMIC FEATURES  
CAR BRAKE DUCTS  
WIND TUNNEL PARTS  
MOCKUP PARTS

## WINDFORM ADDITIVE MFG:

ELECTRIC COVERS AND SPECIAL PIPES  
INTAKE MANIFOLDS

## MECHANICS:

UPRIGHTS/SPINDLES  
ROCKER ARMS  
SUSPENSIONS END FITTINGS

## MECHANICS:

SPECIAL SPLINED EDM PARTS  
GEARBOX  
ENGINE PARTS  
COMPLEX 5X CNC MACHINED PARTS

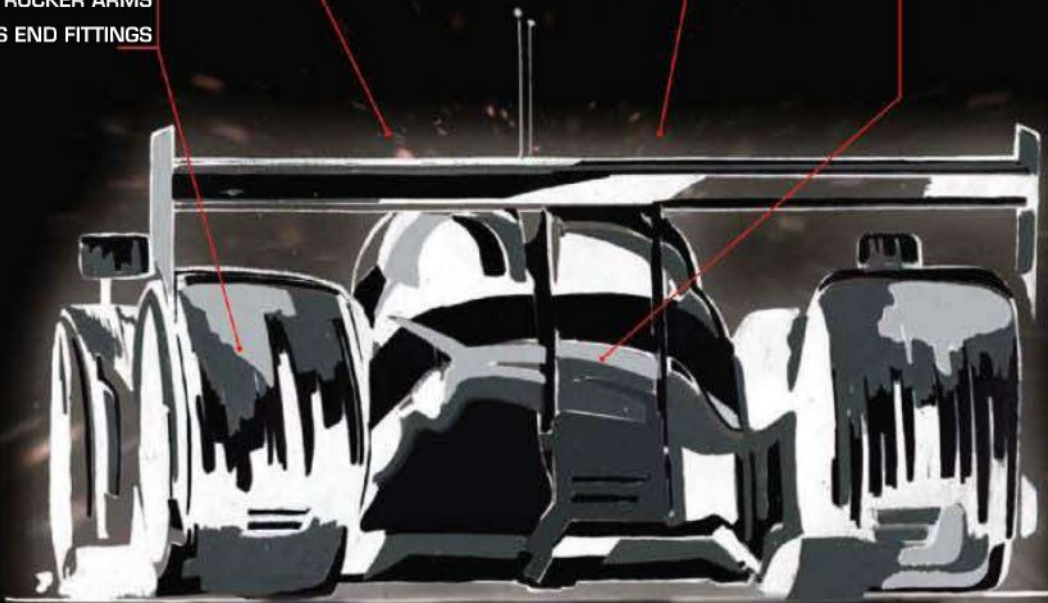

## OTHER WINDFORM ADDITIVE MFG:

MOULD INSERTS  
MASTER MODELS  
SPECIAL JIGS

AT 300 KM/H, QUALITY ISN'T OPTIONAL, IT'S YOUR LIFE!



[www.crp.eu](http://www.crp.eu)

[www.crp-usa.net](http://www.crp-usa.net)

[info@crp.eu](mailto:info@crp.eu)

[info@crp-usa.net](mailto:info@crp-usa.net)

HS CNC MACHINING . ADDITIVE MANUFACTURING . RAPID CASTING . ENGINEERING & REVERSE ENGINEERING  
C.R.P. Group · Via Cesare Della Chiesa 21 · 41126 MODENA · ITALY · Phone +39 059 821135 · Fax +39 059 822071



## NEXT GENERATION DATA ANALYSIS



- > Race proven systems
- > Very high data rates
- > Fully customisable
- > Analysis software included



[www.gems.co.uk](http://www.gems.co.uk)



World leaders in the manufacturer of high performance drive-line and steering rack components, since 1965



**COMPLETE GEARBOXES**  
5/6-speed sequential, H-pattern, heavy duty, dog engagement and synchromesh



**GEARKITS**  
4/5/6-speed synchro, helical, semi helical, straight cut and dog



**DIFFERENTIALS**  
350 fitments – all with Life Time Warranty



**COMPLETE AXLES**  
axle kits, half shafts



**COMPLETE STEERING RACKS**  
quick racks, rack & pinion kits

**PLUS**  
uprights, transfer units, reversing boxes, motorcycle gearkits

And much more for all types of vehicles



See our web site for more info and order on line at [www.quaife.co.uk](http://www.quaife.co.uk) For FREE brochure: Tel 0845 1307400 / 01732 741144 or email [info@quaife.co.uk](mailto:info@quaife.co.uk)

**Motovicity**  
DISTRIBUTION

Motovicity Distribution  
248-307-1570 phone  
248-307-2573 fax  
888-SPEED-16



With the exhaust note emanating from its Corvette V8 engine and an outlandish design philosophy, the new Panoz certainly turns heads

# American dream

How Team PTG are trying to turn Don Panoz's new road car, the Abruzzi, into a successful GT2 car

**T**he *Fountainhead* was produced as a film in 1949, based on Ayn Rand's book of the same name in which an architect defies conventional thinking and holds true to his principals, preferring obscurity by designing modern architecture rather than conforming to traditional styles.

This is a book with a heavy influence on the life of Don Panoz, the founder of the American Le Mans Series and the Panoz road car division. None of the cars produced have followed conventional wisdom - think Panoz LMP 1 and Panoz LMP-07 - and his latest creation, the Abruzzi, is no exception.

The car is front-engined, rear-wheel drive, with a transaxle at the back and a rear-mounted radiator. The road car, which will

BY ANDREW COTTON

see just 81 examples built, breaks new ground in environmental design and construction, starting with the implementation of the Recyclable Energy Absorbing Matrix System.

**production car homologation has yet to be finalised**

But ever the racer, Panoz decided it would be a good idea to turn his new road car into a GT2 contender, to compete against the Ferrari 458, the Porsche 997 and the Corvette Z06. It is the most hotly-contested category in the ALMS, with factory-supported teams and racecars with a sound

road-going pedigree. With that in mind, Panoz decided to rush through the production of the car to have it ready for the 1000-mile Petit Le Mans in 2010.

In the end the rush proved too much, for in Atlanta the car managed only a single lap before it was parked in the paddock

for the rest of the weekend. It was clear the car was not ready, despite Tom Milner's Team PTG working 18 hours a day for 10 days to meet the deadline and get the car to the track.

#### UNUSUAL LINES

At Sebring, however, the picture

was different. The car was still late - it was completely re-built by the team and only ran for the first time on the Saturday prior to the race - but this time it was part of a proper test programme. It was slow and unwieldy, and drivers Benjamin Leuenberger and Ian James were taking some unusual lines through the corners as they lacked frontal downforce. Nevertheless, the car qualified just one tenth of a second slower than the Jaguar XKR of Bruno Junqueira, Christiano da Matta and Oriol Servia and ran for almost 90 minutes in the race before retiring. 'The air compressor for the paddle shift system switched off, but it was a sensor problem,' said Milner. 'Then the crank case pressure went up and we may have scuffed a piston so, rather than risk a big failure, we preferred to stop.'



Engine is the GM LS5 from the company's Corvette range, but with uprated crank, rods, pistons and steel valves

**TECH SPEC**

**Class:** LM GTE (not homologated / unclassified)

**Engine:** GM LS5 V8

**Transmission:** EMCO

**Suspension:** double wishbones, push-rod actuated coil springs over shock absorbers

**Brakes:** Performance Friction,

**Electronics:** MoTeC

**Tyres:** Michelin

**Cooling system:** Ron Davies radiator, six gallon capacity (23 litres)



Rear-mounted radiator is one of the car's more distinctive elements and, unusually, is designed to cool both the engine and the gearbox oil



Despite this, the V8 engine and the car's outlandish design was an immediate hit with the 120,000 or so fans at Sebring, and no doubt if it does run in Europe it will turn heads there, too.

The chassis itself comes to PTG from Panoz, complete with a rollcage that has been changed from the original to accommodate a larger windscreen.

The carbon items are also from Panoz, and the bodywork can fit around the larger tyres permitted in the category this year. Everything else is done by PTG, including the front and rear subframes, and brings together a wealth of American engineering. The gearbox is the same as the Dodge Vipers used when they dominated GTS, the suspension

comes from the Riley Corvette, the paddle shift system was sourced from various parts of the US and assembled by PTG at an estimated cost of \$3500 (£2150) for a working system.

'The software comes from MoTeC, we got an air compressor, a small air tank and so on,' explains Milner. 'The software is the big deal, but why anyone

would pay \$20,000 (£12,275) for a Megaline system I have no idea.'

**WATER COOLING**

The big issue in the Abruzzi is the water cooling system. It works at 100 degrees above ambient temperature, cools the engine and the gearbox oil and, with the radiator in the rear of the car, carries a massive six gallons

of water. 'We cool the engine oil and the gearbox oil with water,' continues Milner. 'There are no oil coolers and the radiator is in the back. At first we thought that would be a problem, but it works better than we expected. You give a weight penalty away because we have a lot of water in the system. The rest is nothing magic.'

The road car uses the Corvette LS9 supercharged engine, but supercharging is not allowed in the GTE category, so instead the car runs with a short block LS7 engine, using a production block, cylinder heads and intake manifold. The valves have been modified and are steel. The team bought a crankshaft, a set of rods and JE pistons, which were the most expensive of the three because they were made in America. The rest were made in China, and cost just \$900. 'They are heavy, sure, but the crankshaft weighs exactly what the Corvette crankshaft weighs, minus 10 per cent,' says Milner.

The car currently runs unclassified in the ALMS, and did not run at Long Beach in April as the street track is no place for a car with such a long wheelbase. Also, production car homologation has yet to be finalised.

Panoz has asked that when the car does go through, it does so with the minimum of waivers, and right now the PTG team are working towards improving the airflow through the car, running dive planes to increase frontal downforce and generate more heat into the front tyres, while the production department pushes through homologation.

For PTG, it is a tough job, but the car has performed better than the Jaguar - just put a good team together, get some good drivers and run it. I want to prove the nay-sayers wrong.'

Clearly, he too has read *The Fountainhead*.



... hit the track  
**RUNNING**

**EMCO**  
GEARS.

Established 1974

The 46P1 sequential gearbox is designed & built using the latest in engineering software, materials & manufacturing processes to provide the maximum in performance.

**46P1**

EMCO designs & produces reliable & versatile racing transmissions as well as precision systems such as uprights, steering racks & axle systems.

EMCO is a premium supplier of nearly every major professional motorsport series worldwide, including NASCAR, IndyCar, Grand-Am & ALMS.

**LATEST NEWS:** EMCO Gears has relocated to a larger facility! Our expansion is thanks to our growing customer base & their demand for the quality products & services that EMCO Gears provides.

**NEW EXPANDED FACILITY!**

160 King Street, Elk Grove Village, IL 60007 | ph: 847.220.4327 • fx: 847.220.4329

[www.emcogears.com](http://www.emcogears.com)

**young**  
calibration

**TEST AND CALIBRATION  
SERVICES FOR THE  
HIGH-PERFORMANCE  
MOTORSPORT INDUSTRY**

- > Calorimetric Heat Exchanger Performance Testing
- > Radiator, Oil, Transmission and KERs' Coolers
- > Core Cleaning Services
- > Instrumentation Calibration Services

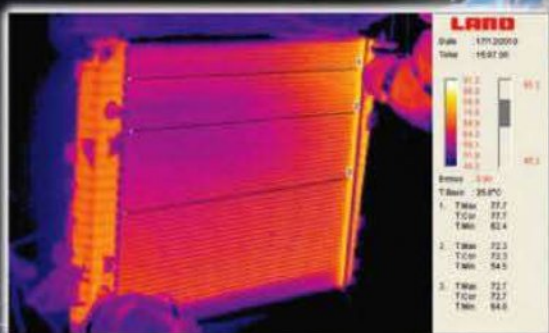

UNIT 4, HAM BUSINESS CENTRE, BRIGHTON ROAD,  
SHOREHAM BY SEA, WEST SUSSEX, BN43 6RE  
Tel: +44 (0)1273 455572

[www.youngcalibration.co.uk](http://www.youngcalibration.co.uk)



# The 88000 experiment



It's the early 1990s. CART runs the PPG IndyCar World Series and Team Penske is developing a top secret suspension system...

**M**otorsport history is littered with bright ideas that never quite made it to the racetrack. This is the tale of one such project - perhaps one of the most secretive in IndyCar history.

It's 1992, and Penske's most recent championship win was 1989, in what must have been something of a bittersweet affair. A Patrick Racing-run PC18 with former Formula 1 world champion Emerson Fittipaldi, took the drivers' title from Team Penske's Rick Mears by a mere 10 points. Penske Racing did, however, win the chassis constructors' cup, Danny Sullivan adding a couple of wins as the PC18s won 10 from 15 races. But Lola then took the

BY SIMON MCBEATH

1990, '91 title, and ultimately went on to win the '92 drivers' and constructors' titles. This went down like the proverbial lead balloon in an ultra-competitive organisation like Penske Racing, and similarly so at Penske Cars, the design / manufacture side of the operation in England. But, as Roman poet Horace said, 'adversity reveals genius', and one of the projects initiated during 1992 in an effort to get back in front of Lola again was something very few people even within Penske Racing or Penske Cars knew about then, or indeed much later. For a hydro-mechanical active suspension system was

being covertly developed in the States.

#### THE MOOG CONNECTION

Fast forward to August 2010, when the project came to light in a chance remark by Martin Jones, motorsport market manager at Moog, who mentioned that in 1992 Penske had contacted Moog about such a system. Jones had even sketched a concept design (see figure 1, overleaf). From here the trail led to former senior personnel at Penske Cars and, during a subsequent, fascinating meeting in January 2011 with three former team luminaries - Penske Cars' managing director, Nick Goozee, chief designer, Nigel Bennett, and Team Penske race engineer, Nigel Beresford, some

background to the 'active' project re-emerged.

Bennett initially took up the tale and recounted that, 'normally for a road course the car would be run quite soft and be allowed to go as low as possible at speed, but this meant it was high in slow corners. So we did some tests on a skid pad at Black Lake, Detroit, where we lowered the car as much as possible and measured the gains, and we found a *lot* of lap time. So clearly there was much to be gained if we could control the ride height. And this naturally led to the notion of actively controlling ride height to keep it as low as possible at all times.'

Goozee cast an interesting light on the culture imbuing the

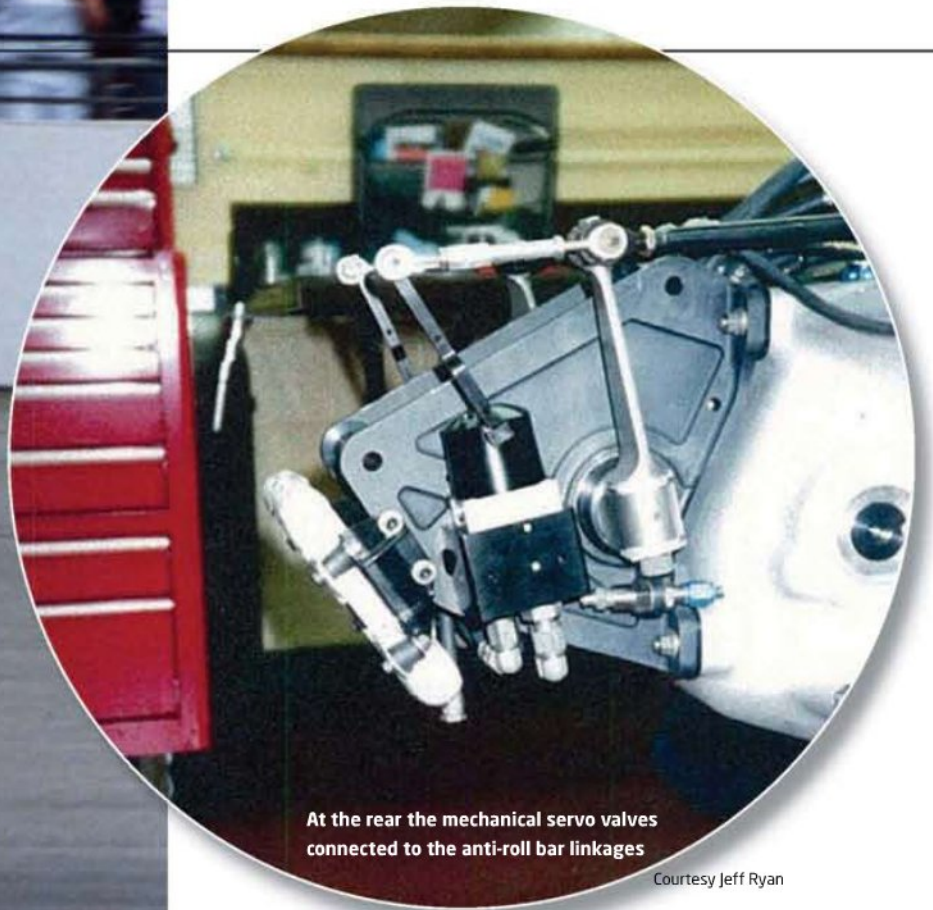
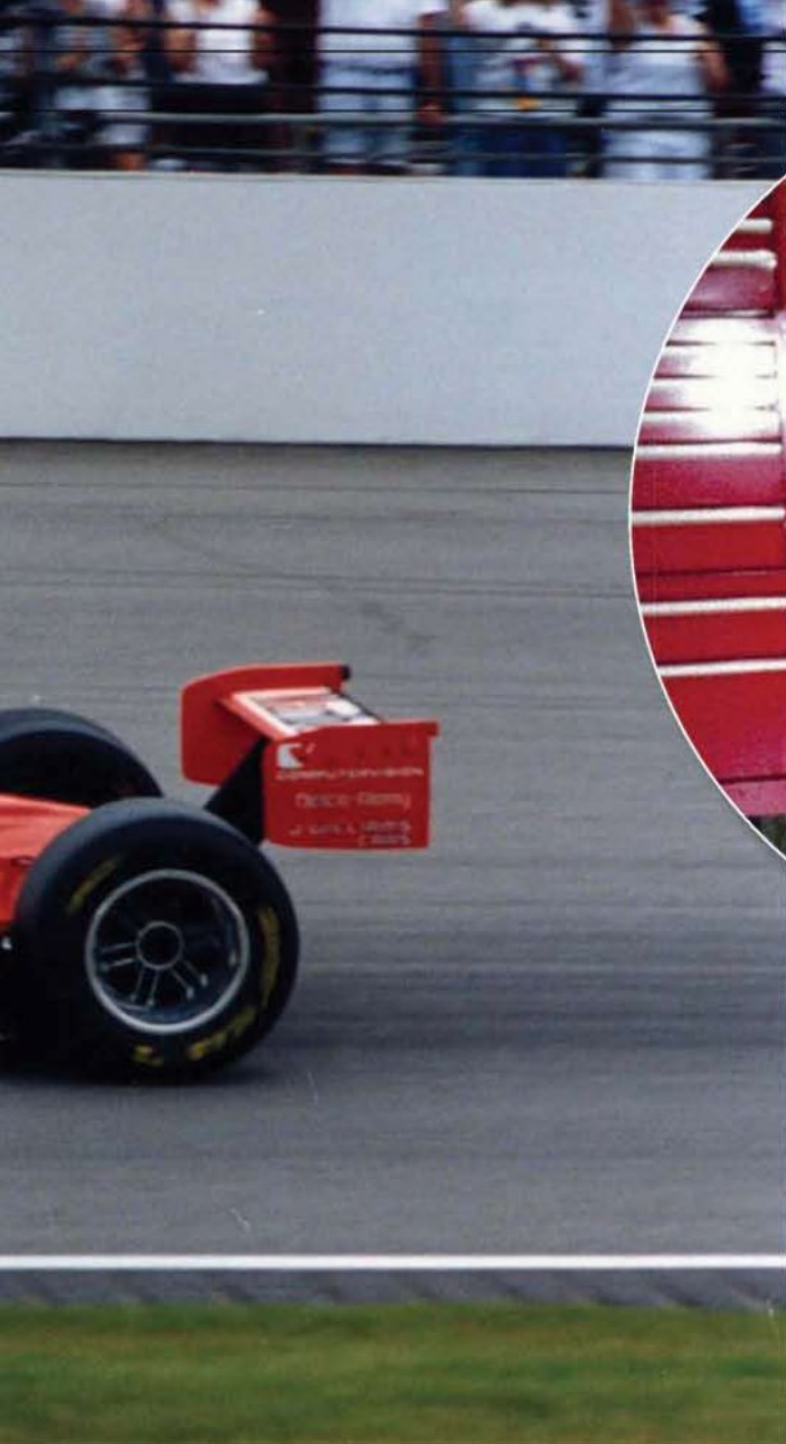

At the rear the mechanical servo valves connected to the anti-roll bar linkages

Courtesy Jeff Ryan

design and manufacture side of the organisation throughout this whole period: 'When I first mentioned *Racecar Engineering's* enquiries about the active project to the two Nigels in late 2010 they were quick to remind me that at Penske Cars all 'technical speculation' had to be approved by me before the designers proceeded with their investigations. You have to understand that Roger Penske was very conservative, and he didn't like doing what nobody else had already done. If I had said to him we were pursuing a particular line of thought he would immediately ask 'who else has done it?' We were also very conscious of costs and avoiding blind alleys.'

Bennett continued this theme: 'RP [Roger Penske] also felt that if we had the same equipment as everyone else we'd win simply because we were Team Penske. So why did we need bright ideas?' This rather begs the question, in that case why design and build your own cars? And although having their own design and manufacturing facility provided a rate of responsiveness that the other teams struggled to match, maybe RP supplied the answer to that question in later years when racecar construction ceased at Penske Cars altogether and the team switched to running Reynards. But we stray off topic here. The point is that there was a degree of corporate resistance to innovation on the one hand

but, as Beresford remarked, 'the early '90s was also a period of sustained innovation. You needed a couple of performance differentiators to be competitive.'

#### STATESIDE DEVELOPMENT

In this instance, though, the innovators won the argument and a project to develop an active ride system was set up with the test team in the States. Jeff Ryan, then at Penske Racing Shocks, though now technical director of JRI Shocks, recalled: 'When I learned that Penske Racing and Penske Cars were considering a type of active suspension or ride height control, I introduced them to Gary Denton. I first met Gary, I believe in 1991, while

chassis, along with Penske Cars' engineers.'

Over then to Denton, now a designer of clinical diagnostic analysers for a healthcare company in Rochester, NY, who, fortunately for us, says he never forgets anything, 'except where he's parked his car or left his glasses': 'I had worked with Penske Racing Shocks and had expertise in adaptive and semi-active suspension design. Nigel Bennett contacted me and asked if I would be interested in designing a fully active suspension for an IndyCar. The project was top secret and not to be revealed to even the race team, and it was to be dubbed the 8800 system. The current shock

**there was much to be gained if we could control the ride height**

cooperatively working on an electronic shock programme. So he was hired by Penske and housed at Penske Racing Shocks to keep the programme out of the mainstream day-to-day activities in the race shop. Gary's responsibility was the overall system and integration into the

for IndyCar was called the 8700, so we called it the 8800 to not arouse suspicion that anything new was in the works.'

Denton's astonishingly clear recollections of the run up to the project neatly summarise the underlying premise, too: 'I was not yet working for Penske

CUSTOMER APPLICATION WORKSHEET

MOOG  
CONTROLS LIMITED

CUSTOMER: N/A  
SKETCH No. C.W. 274, SHEET 1.  
PREPARED BY: M.S. JONES. DATE: 26-5-92.

APPLICATION OF A MOOG DIRECT MECHANICAL INPUT VALVE TO ACTIVE RIDE HEIGHT CONTROL:

① (POSSIBLE MECHANICAL ARRANGEMENT):

CONCEPT SKETCH ONLY:

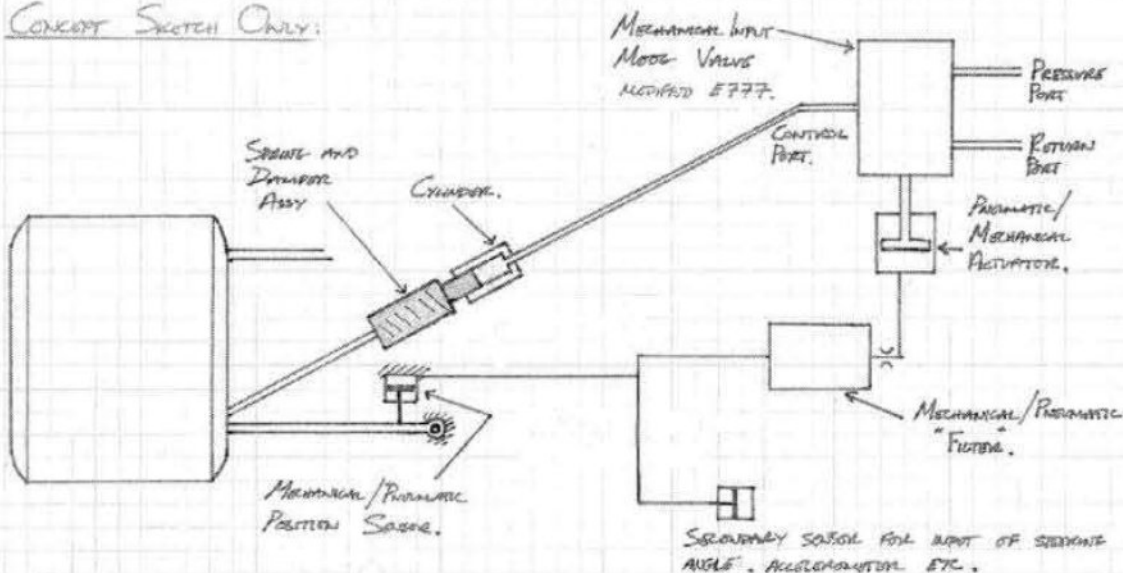

MOOG CONTROLS LIMITED, AMBURNHURD TERRACE, WALSLEY, G14 7NL, TEL: 01924 614111, FAX: 01924 614112  
58 King Street, U.S.A. - 10000 Old Orchard Road, North York, Ontario - 416-491-1000 - 10000 Old Orchard Road, North York, Ontario - 416-491-1000

May 1992 0.010

Courtesy Martin Jones, Moog

Figure 1: concept schematic by Moog's Martin Jones of a possible hydro-mechanical active ride system. As it transpired, Penske's system was quite different

when Nigel Bennett first told me about the test where he ran a car around a skid pad. It was determined by Penske engineers that the additional ride height required to prevent the car from bottoming at the end of the straight due to downforce was about one inch. Therefore, if a car would not need this additional ride height, in slow-speed corners it could go faster. Additionally, softer springs could be employed, making the car more compliant to bumps, with an active suspension reducing the additional pitch and roll normally associated with a soft suspension.

'CART rules didn't allow electronics to be used on the suspension, so a mechanical method to run a servo system was needed. We consulted with Moog in the UK. A servo valve normally uses an electrical coil to induce a torque on a tube inside the valve. This causes the flow of hydraulic oil to be directed one way or another. An electrical embodiment of an active suspension would use a position



Courtesy Martin Jones, Moog

**Moog experimented by converting one of its servo valves to mechanical operation to prove the principle would work**

sensor to sense the ride position and a computer would send an electrical signal to the servo valve to direct the valve to adjust a hydraulic cylinder to adjust the ride height. For the mechanical suspension system the electrical coil was removed from the valve and a spring was fastened to the tube inside the valve to provide a function where displacement of the spring induced a force on the tube, thereby sending the flow in the desired direction [see figure 2, above right].

The velocity of the flow was

also proportional to the amount of displacement of the spring. We carried out these modifications to the standard servo valve that Moog supplied. The spring was connected to a shaft, which was fastened to a pivot arm, which in turn was connected to the rocker arm of the suspension. As the rocker arm moved in response to downforce, pitch and roll motions, the servo valve reacted and fed a hydraulic cylinder that extended or compressed to keep the rocker arm at a consistent ride height [see figure 3, below right]. We had partnered with a couple of Formula 1 teams running active suspension at the time and from these we derived a couple of different system input versions, the most successful of which had a single servo valve at the rear

(using average rear ride height) and two at the front.'

**SPECIAL SHOCKS**

Back to Jeff Ryan to expand on the role he undertook: 'My responsibility was the design of certain hardware such as actuators, dampers and some of the plumbing. At this time I was very fortunate to be working with, or assisting, a number of leading F1 teams while they developed fully electronic active systems. Some of this was just producing actuator parts or internal components for damping elements. Tom Janiczek was my senior engineer at the time that assisted me on this project.

'The damper / actuators were reminiscent of those on the Chris Murphy-designed Lotus 107 and

the velocity of the flow was proportional to the amount of displacement of the spring

# Heavy-duty

spherical bearings and rod ends  
for motorsport

Certified as per EN 9100!

- The art of performance
- Driven by quality
- Power – Precision – Passion
- Smart way of moving



## HIRSCHMANN

HIRSCHMANN GMBH · D-78737 Fluorn-Winzeln  
Phone: +49 (0) 74 02/1 83-0 · Fax: +49 (0) 74 02/1 83-10  
www.hirschmanngmbh.com · info@hirschmanngmbh.com

# THE SCIENCE OF AERODYNAMICS

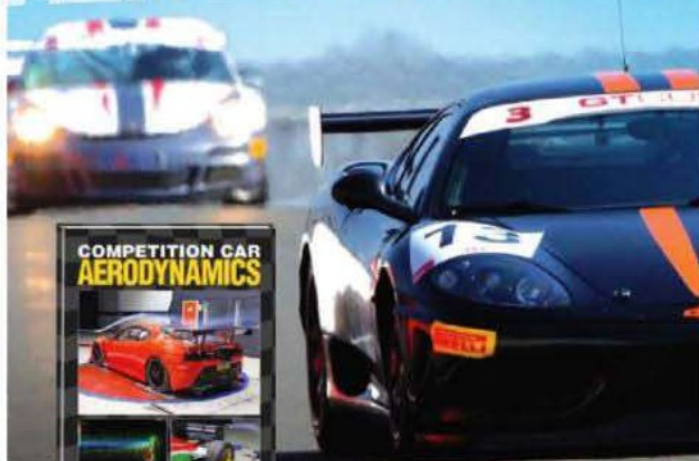

This fully updated second edition covers all aspects of aerodynamics, including both downforce and drag

**OUT NOW | £25.00**

www.haynes.co.uk/aerodynamics  
Available from all good bookshops or  
ORDER DIRECT on Tel: 01963 442030

**Books for enthusiasts  
by enthusiasts**

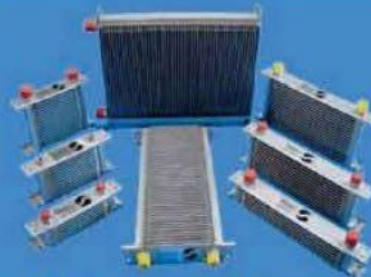

**MOCAL** High performance  
air to oil coolers



Oil cooler  
installation kits



Remote filter heads  
& take offs



Electric water pumps,  
release engine power



Dashboard gauges



Oilstats control oil  
temperature for  
more power & mpg



**LAMINOVA**  
oil to water coolers



Electric oil pumps for  
transmission cooling



Holley & Facet  
fuel pumps



Custom hoses for oil, fuel,  
brakes & coolant, Aeroquip,  
ProGold, Moquip & Speedflow



World biggest filler  
cap distributor



Early warning  
switches & bulbs

Manufacturers of  
**MOCAL & Moquip**  
oil cooling equipment.  
Distributors of automotive  
fluid control products.  
Online shop @  
www.thinkauto.com  
Catalogue £2 refundable.

# Think Automotive

**www.thinkauto.com**

292 Worton Road, Isleworth, Middlesex, TW7 6EL  
Tel 0208 568 1172 Fax 0208 847 5338  
Email info@thinkauto.com

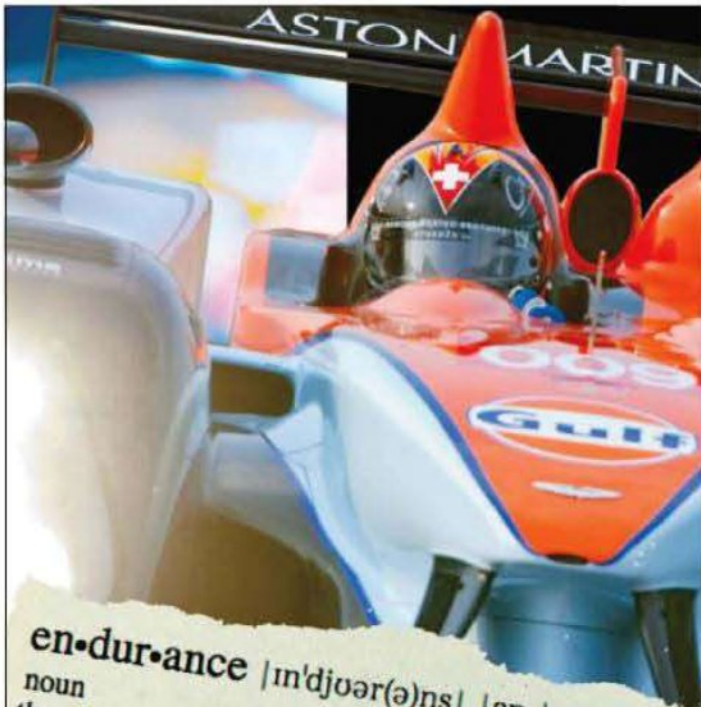

**en·dur·ance** |m'djʊər(ə)ns| |en-|  
 noun  
 the ability or strength to continue or last, especially under stress, or other adverse conditions;  
 • the capacity of something to last or to withstand wear

**ORIGIN** late 15th cent. (in the sense [continued existence, also as *indurance*): from Old French, from *endurer* 'make

Goodridge fluid transfer systems, built to last

*lap after lap, race after race*



**PUSH THE LIMITS**

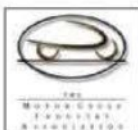

**GOODRIDGE**

FLUID TRANSFER SYSTEMS

GOODRIDGE LTD, EXETER, EX5 2UP, ENGLAND

[www.goodridge.net](http://www.goodridge.net)

UK • USA • GERMANY • FRANCE • HOLLAND • SPAIN • JAPAN

NEW: CAN DISPLAY



**KMS**  
**Kronenburg Management Systems**



Kronenburg Management Systems (KMS) is a complete line of engine management systems, that offers you an extremely reliable and user-friendly system at a very competitive price. It gives you the possibility to manage all (turbo + n/a) petrol engines up to 12 cylinders with options such as 4mb datalogging, staged/banked injection, mapselector, odd firing, self-learning lambda control, boost control, variable launch control, idle control, traction control, powershift, rpm limiters, engine diagnostics, shift-light, water injection, cooling fan, fuel pump, etc. New KMS CAN display, UEGO CAN controller and MAP sensors now available.

For more information, free software and prices:

<http://kms.vankronenburg.nl>

**KMS**  
**Kronenburg Management Systems**

KMS Management Systems  
 Spaarpot-Oost 19, 5667 KT Geldrop, The Netherlands  
 T. +31(0)402854064, F. +31(0)402867765  
 E. [info@van-kronenburg.nl](mailto:info@van-kronenburg.nl)

**DOCKING**  
 Advanced Cooling Systems

Water Radiators  
 Intercoolers  
 Oil Coolers  
 Heat Exchangers  
 System Design  
 Ancillary Products

Manufactured to your requirements by the UK's leading supplier.

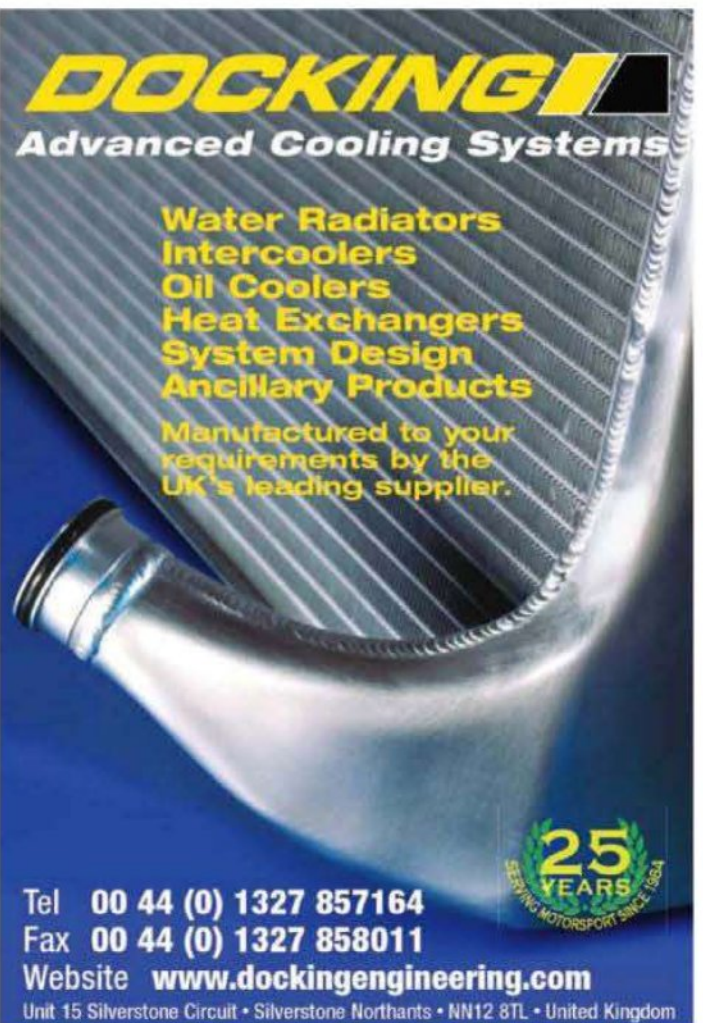

Tel 00 44 (0) 1327 857164

Fax 00 44 (0) 1327 858011

Website [www.dockingengineering.com](http://www.dockingengineering.com)

Unit 15 Silverstone Circuit • Silverstone Northants • NN12 8TL • United Kingdom



I can't recall which came first, the Lotus or the Penske. We did both so there were some design synergies. The idea behind the damper / actuator was to have a damper attached to the dual acting cylinder actuator to handle the higher frequency, lower amplitude inputs, and the active cylinder actuator for the lower frequency, higher amplitude motion. This would effectively control ride height, or try to, and maintain a more even aero platform.

'A spring was placed over the 3000psi operating cylinder for redundancy if there were a loss of pressure. It was pre-loaded to keep the corner of the car off the ground in case of a failure. So essentially this was a damper with a fast acting actuator for an upper mount, allowing for the coilover unit to extend and retract in length to raise and lower the chassis.'

Ryan also displayed remarkable recall with some fascinating detail: 'The actuator shaft was a one-piece shaft and piston from billet 300M [high strength steel], hollowed and plugged with hard chrome inlaid onto the operating surface area. Seals were a 5000psi, low friction, small footprint polymer, supported by a carbon / Teflon band on each side of it. The actuator shaft bearing housing was 6AL-4V titanium alloy with a 5000psi Teflon rod seal and DuPont Vespel [polyimide] as the bearing surface material.

'The tandem damper actuator bodies were from 7075-T6 aluminum with a hard anodised finish, internally honed. The ports for the actuator had to be parallel to one another because of the coil spring over the actuator assembly. A series of small holes were drilled radially in the length of the actuator cylinder body to feed the upper chamber in order to pull the chassis down. This was a challenge due to the cylinder length, thin cylinder wall and required hydraulic flow.

'The plumbing into the actuators were -3 braided stainless steel lines with thin titanium banjos we manufactured for a tight, clean fit. The damper unit itself was an early pre-production design of the 8760 piggyback unit, a three-way

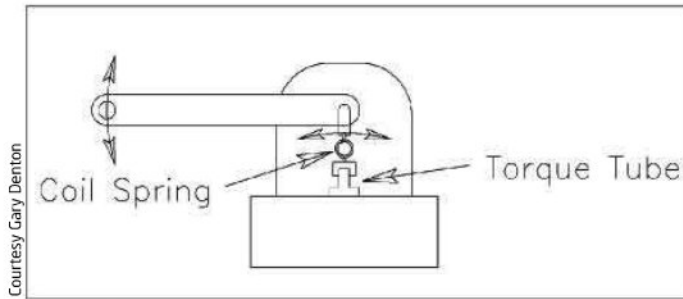

Courtesy Gary Denton

Figure 2: the final iteration of Gary Denton's mechanical servo valve used the same principle as Moog's but a different design

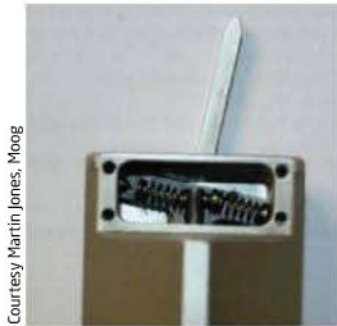

Courtesy Martin Jones, Moog

A lever connected to springs that exerted force on the internal servo tube, directing hydraulic fluid flow

adjustable damper with high and low speed in compression and a single bleed adjustment in rebound.

'We also assembled from an existing dyno platform a test rig for early evaluation of the system and its mechanical components, and it consisted of a 3000psi pump, accumulator, cooler, Moog valve and supporting hardware. We suspended the upper dyno mount, which is usually fixed hard, and were able



Close up of the left-hand side linkage, showing the hydraulic fluid cooler

to put mass on this in different load configurations in order to adjust valves for the ride height, amplitude and frequency control, and to better fine tune the mechanical parts that replaced the electrical.'

**HYDRAULIC SYSTEM**

Of course, there was no pre-existing hydraulic system on the racecar either, so all the requisite components needed sourcing and installing. A hydraulic reservoir was initially installed inside the transmission housing but, after discovering that 'this was not a suitable environment for hydraulic fluid', it was re-located into one of the sidepods. The system pump was initially mounted 'very inaccessibly' on the engine and again later moved into the sidepod. There was also an accumulator, a filter and, somewhat enigmatically, an electrical valve to turn the system on and off, which somehow was allowed under CART rules.

Denton again: 'The first system seemed to work well on the rig, except when we blew a hose and filled the shock dyno room with oil mist! For testing remote from the race shop, a hydraulic pressure unit was needed, and a local engineering firm built a petrol-powered unit. Not being in the racing business, the result was a bit "industrial" and the mechanics humorously named it Big Bertha. Long hoses were quickly made up to get the

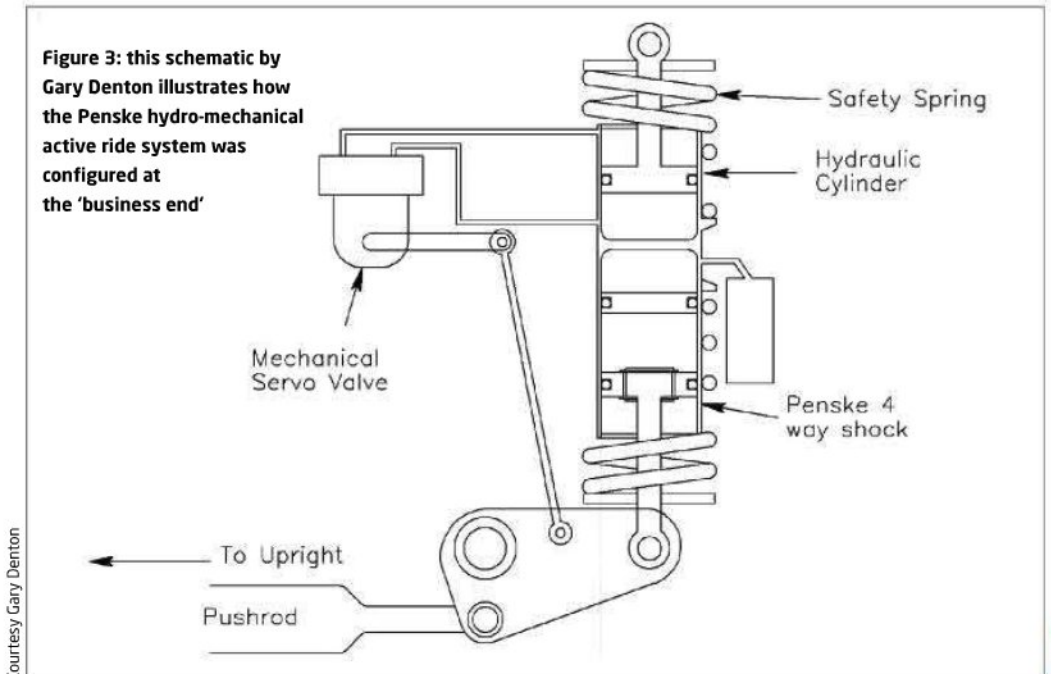

Courtesy Gary Denton

Figure 3: this schematic by Gary Denton illustrates how the Penske hydro-mechanical active ride system was configured at the 'business end'

*Performance Starts Here...*

*Supertech Performance*



**High Performance**  
Engine Valves, Pistons and Components





In this pre-installation view, the actuators are at the top, towards the engine



In this shot from the rear, the 'myriad hydraulic lines' are clearly visible

loud, smelly, awful thing as far away from the car as possible!

The first car tests were at the Transportation Research Center in East Liberty, Ohio, with Emerson Fittipaldi driving. A lack of grip from the surface resulted in a lot of opposite lock. Nevertheless, although the test ended with the destruction of one of the servo valves from the high vibration environment, the system performed well enough to warrant a second test. This was with Paul Tracy, and we were able successfully to control the ride height without negative complaints of harsh ride from Paul. The final test was at

Firebird East racetrack in Phoenix, Arizona. We were able to produce lap times faster than the standard car but we were starting to get some 'too harsh' comments from the drivers because the system was reacting to bumps as well as large ride motion inputs. We also broke a hydraulic line near the engine and the car caught fire, which was quite exciting... In fairness, we had our share of oil spill moments during the programme. One of the mechanics told me I owed him a good tool box cleaning as his spanners were not going to rust any time soon!

'Overall, I would say that the design proved to be quite



The front installation showing the upper actuators with the redundancy springs pre-loaded and installed. The two mechanical Moog valves can be seen at the front of the nose box in front of the ARB blades



Another front installation showing the banjo fittings feeding the actuator. The damper portion is at the bottom (right), towards the Moog valves

a challenge in the set up of the system and the difficulty of test-ability. Instead of making a rapid software change, an entire mechanical system needed to be designed and fitted to make a change to simple inputs. But it worked well at Firebird and reduced lap times. Penske was looking to get a clear one-second-per-lap improvement. I don't know that we got all the way there, but it was better, and by a

failed you could just turn it off and default to normal ride heights to finish the race in passive mode. Whether it would have been race-able, well, we tested it for many laps at Firebird, but it would it have been a royal pain in the mechanics' ass to set up and maintain. No one liked being all oily either. So, given the difficulty of system set up, the expense and the logistics of racing such a system, Penske decided not to

**it would have been a royal pain in the mechanics' ass to set up and maintain**

lot. It was also reasonably driver friendly - the driver didn't have to do anything different. The car handled pretty much the same, and comments of increased harshness were the only negatives from the drivers.

'Of course, the car would likely have been less reliable overall with the addition of so many more complex components. But I did design it so if the system

pursue development after the first year.'

Denton rounded off the story with some personal thoughts: 'Working in a culture in which a big change is moving the ride height 0.080in (2mm) or adjusting a shock setting by two clicks, making a quantum leap to active suspension was a very hard sell. But I must say, for as radical a system as this was, the



test team did a fantastic job. I often wonder if the race team boys were just letting us have our fun until they ultimately pulled the plug... But I also remember [team manager] Chuck Sprague writing a letter to CART explaining the system that we had been developing, and very shortly thereafter CART put specific new rules in place to ban it.' So that was that.

However, for 1993, the beautiful Penske PC22 Chevrolet appeared, the latest creation of chief designer, Nigel Bennett, and his team, representing a significant step forward compared to the previous year's PC21, according to our V3N1 feature. Beresford recalled that, 'the PC22 was actually very competitive. We had a sequential gearshift and what we called a 'monobump' device, later referred to as a third spring that year.'

The reference to the 'monobump' is interesting, reflecting the quest for similar goals to active suspension. During the close season of 1992/'93 Beresford was snowed



Jeff Ryan (left) and Gary Denton looking happy with their work

in at Philadelphia airport, and time-filling conversation with colleague Grant Newbury, Fittipaldi's race engineer, turned to the Tyrrell F1 car's monoshock. 'This had decoupled roll from heave, allowing Tyrrell to run a stiff heave spring and low front ride height without an attendant increase in roll stiffness.' Grant suggested we

should try something similar with bump rubbers, so we discussed how we could do it with twin springs. And that led to the third spring idea in early 1993. That enabled the car to be run really low without affecting roll stiffness.' In the end, the PC22 won the 1993 Indianapolis 500, and a further eight races during the season, Fittipaldi losing the

drivers' title to 'rookie' Mansell by only eight points.

The following season, 1994, was a legendary year for Penske, with pole and victory in the Indianapolis 500 with the 3.4-litre Mercedes pushrod engine, a clean sweep of the top three positions in the PPG IndyCar World Series driver's championship and, with 12 wins from 16 races propelled by the new Ilmor Mercedes engine, the chassis constructors' title, too. And all this without active ride suspension.

But, as in Formula 1, the inevitable question is left hanging - how would the future have panned out if CART had not closed this particular development door? 

Racecar Engineering's thanks, in order of contact, go to Martin Jones at Moog, Nick Goozee, Nigel Bennett, Nigel Beresford, Gary Denton, Jeff Ryan, now at JRi Shocks, and Jim Arentz at Penske Racing Shocks for their invaluable help with compiling this article.

## ACTIVE SHOCKS ON TEST

➔ Penske Racing Shocks currently offer a patented active shock system, named the 3000 series, but it is meant to act solely as a test component, not an 'in-race' active damping system.

The fully hydraulic set up utilises high performance Moog DDV valves to control bypass flow across the main damper piston. At the heart of the dampers are standard Penske internals to maintain passive / active correlation. However, the control valve allows for an infinite spectrum of damper curves within a wide damping range to allow complete DOE studies without removing dampers from the car. The time savings of such a system are considerable on the seven-post rig, and even more so at the track as tyre heat cycles are minimised, and drivers can remain focused on car set up evaluation vs regular trips to the pits for damper adjustments or replacement.

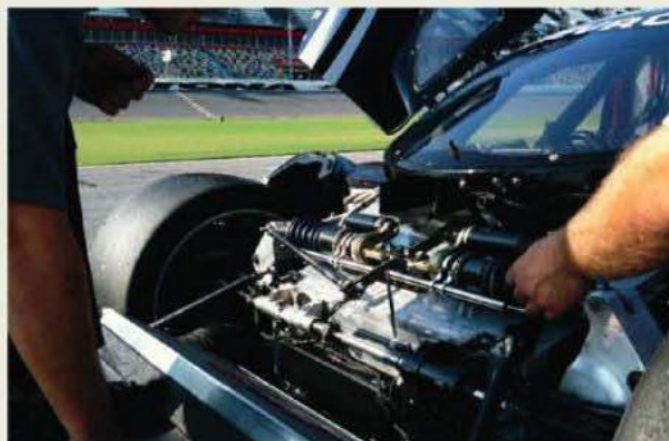

The 3000 series dampers in use on the Crawford DP08 at Daytona

The system appears to be robust, having been run on track at Daytona in a Crawford DP08 Daytona Prototype Chassis throughout 2009. Penske and the Childress-Howard teams integrated control of the damper maps and DOE by the driver from the cockpit using a selector switch. After each test stint, a new catalogue of maps were downloaded to the system from

the pit wall, based on trends noticed in the data. This method of testing allowed the team to find optimum damper settings within limited track time, reducing the need for costly additional test days.

Dave Wagener, Childress-Howard chassis engineer, commented, 'We were able to set up an organised and detailed test plan with the engineers

from Penske. During this test, we were able to sort 25 different damper combinations in a total of eight outings. During each outing, the change was evaluated against our base damper configuration, eliminating effects due to tyre wear and a changing track. This type of test would not be possible with passive dampers due to the number of sets required and time off track required to make changes. Using this system not only saves preparation and track time, it also saves money.'

The system is also in use in NASCAR, with front runners, Hendrick Motorsports, amongst its customers, who are similarly impressed by the technology, as the team's shock specialist, Jason Seitzinger, explains: 'The Penske active system has helped us save time on the rig, and allows for the testing of new damping curves we would never have time to evaluate.'

**Stockists  
of high  
performance  
metals to the  
world's most  
demanding markets**

## **CR14 Titanium Alloy**

- **A new Generation Ti Alloy for Motorsport, Defence & Aerospace applications**
- **A new Titanium Alloy system is a combination of proprietary chemistry, thermo mechanical processing and heat treatment**
- **Ingots produced by Timet**
- **A unique balance of low density, high strength, ductility and stiffness, which exceeds all known production Ti Alloys**
- **Machining techniques such as milling, turning, gun drilling, honing and grinding applications have all been established for the material**
- **Density (g/cm<sup>3</sup>) 4.35**
- **Data for single extrusion condition**
  - 0.2% PS (MPa) 940 (RT)
  - UTS (MPa) 1100 (RT)
  - EI (%) 16.3
  - E (GPa) 132
- **Data for the double extruded condition**
  - 0.2% PS (MPa) 1350 (RT)
  - UTS (MPa) 1360 (RT)
  - EI (9%)
  - E (GPa) 135
- **High ductility, good strength at low temperature**
- **Good ductility, high strength at medium temperature**

### **Motorsport applications:**

- **Inlet valves**
- **Connecting rods are proven, showing a 15% mass reduction when compared to competitive designs in Ti 64 and SP700**
- **Gudgeon Pins; Lower mass than hollow Steel and solid Ti Al applications**
- **Turbocharger impellers**
- **Quill shafts**
- **Valve train top retainers**
- **Developments for exhaust valves**

### **Overall CR14 offers**

- **Lighter, stiffer improved component life when compared to those made in Ti 6242, Ti 6246, SP700 and Ti 64.**

**Smiths High Performance** Unit 0, Stratton Business Park, London Road, Biggleswade, Beds SG18 8QB

**Tel: +44 (0) 1767 604 708 Fax: +44 (0) 1767 312 885**

**[www.smithshp.com](http://www.smithshp.com)**

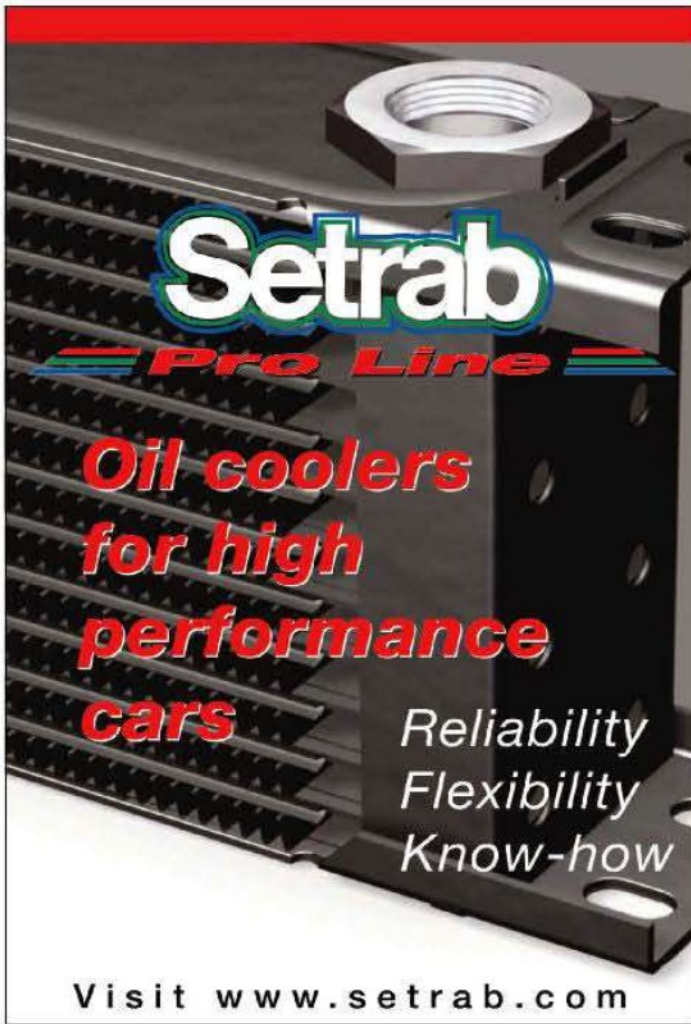

**Setrab**  
**Pro Line**

**Oil coolers  
for high  
performance  
cars**

Reliability  
Flexibility  
Know-how

Visit [www.setrab.com](http://www.setrab.com)

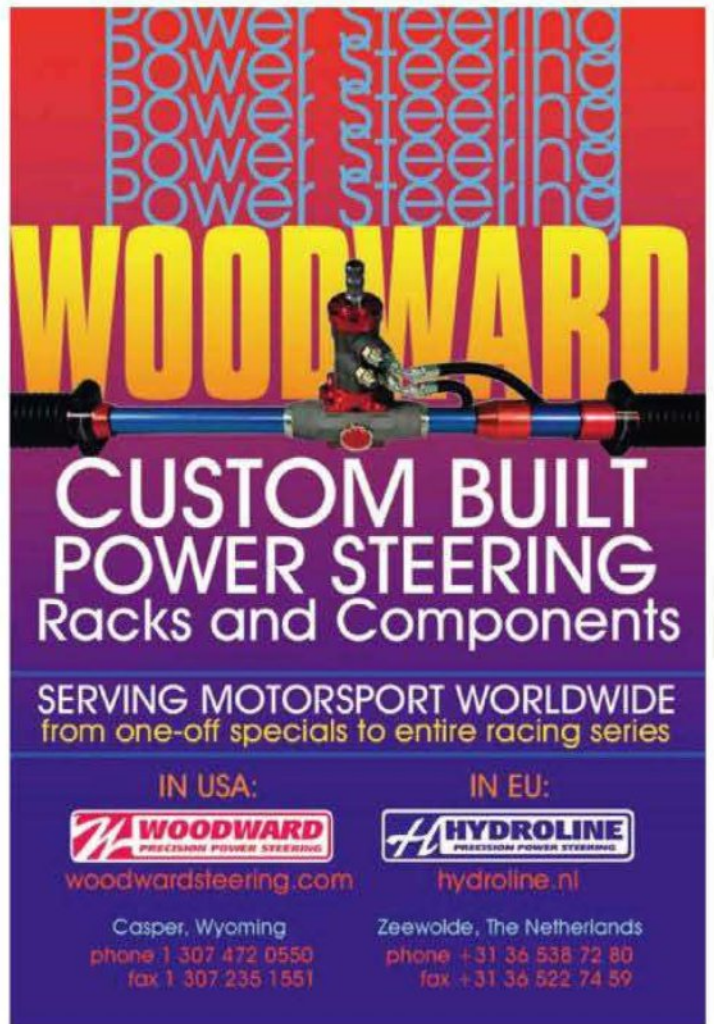

**WOODWARD**

**CUSTOM BUILT  
POWER STEERING  
Racks and Components**

SERVING MOTORSPORT WORLDWIDE  
from one-off specials to entire racing series

IN USA:  
**WOODWARD**  
PRECISION POWER STEERING  
[woodwardssteering.com](http://woodwardssteering.com)  
Casper, Wyoming  
phone 1 307 472 0550  
fax 1 307 235 1551

IN EU:  
**HYDROLINE**  
PRECISION POWER STEERING  
[hydroline.nl](http://hydroline.nl)  
Zeewolde, The Netherlands  
phone +31 36 538 72 80  
fax +31 36 522 74 59



**EARL'S**  
PERFORMANCE PRODUCTS

CUSTOM BRAKE LINES | OIL COOLERS | HOSE | FITTINGS  
ADAPTERS | FILTERS | NOS | FUEL PUMPS & REGULATORS



FUEL LAB NOS Holley EARL'S VDO STAUBLI

Visit [www.earls.co.uk](http://www.earls.co.uk) for the full range  
Online Shop now Available

Earl's Performance Products UK Ltd  
Units 15-16 Silverstone Circuit, Northants, United Kingdom NN12 8TL

QUOTE "RCE10"  
WHEN ORDERING TO  
RECEIVE 5% DISCOUNT

+44(0)1803 869850 | [sales@earls.co.uk](mailto:sales@earls.co.uk)

Contact: Gordon Riseley  
email: [griseley@ringspann.co.uk](mailto:griseley@ringspann.co.uk)



High Performance  
Motorsport  
Gearshift & Throttle Cables

**RCS** [www.RCScables.com](http://www.RCScables.com)  
Tel 01234 342511

**RCS - Cables and Controls**



# Cool runnings

It may not grab the headlines like KERS or f-ducts, but the development of efficient cooling systems is every bit as important as any other area of a racecar

It can be taken as read that in the upper echelons of motorsport, be it F1, IndyCar or NASCAR, the devil is in the detail. With teams often separated by hundredths of a second, any possible gain is seized upon in a bid to claim the upper hand. But one area that is often overlooked by the mainstream media is the importance of a car's cooling system, not only in terms of providing cooling capacity, but also the related packaging and drag issues. By and large, modern racecars still rely on water-to-air coolers to transfer heat out of the engine, and oil-to-air coolers for the lubricating fluids. In the case of single seaters and Prototypes, these tend to be mounted in

BY LAWRENCE BUTCHER

the sidepods, while for most GT cars the chosen location is in the nose area. Obviously, the primary concern with the development

**F1 cores need to be able to withstand in excess of 3.75bar pressure**

of these systems is ensuring sufficient cooling capacity to keep the engine operating comfortably under race conditions. However, in F1 and IndyCar especially, the level of coolant carried is pared down to a minimum, both

to reduce weight and minimise parasitic losses through pumping. The upshot is that the efficiency of coolers, be they for water, oil or other fluids, is paramount, and the focus of considerable research.

This research can be broken

down into three key areas: thermal efficiency, coolant flow through the unit and the performance of the cooler once packaged in its final location.

In order to minimise pumping losses within an engine, the

flow of coolant needs to be as efficient as possible, and this includes within the cooler matrix, as well as any internal passages and pipework. Top teams will often build radiator cores to their own exacting specification in house, but there are a number of manufacturers capable of producing the quality of cores demanded by top-level teams.

The internal pipework and external finning of these units is optimised using CFD, to ensure the most efficient fluid flow through the system, while providing the maximum possible surface area for cooling.

And manufacturers are constantly striving to improve the performance of all parts in a system. The latest cooler

developed by US company Mezzo Technologies, for example, designed specifically for the Honda-engined Dallara IndyCar, contains over five miles of 0.5mm bore pipework. The result is a reduction in coolant temperature of 8degC over previous designs of the same size.

In F1, the cores also need to be able to withstand in excess of 3.75bar pressure, the maximum allowed by the FIA regulations. At this pressure the boiling point of the coolant increases to around 120degC, allowing for smaller radiators to be run. This, in turn, allows for smaller inlets, reducing the drag penalty on the overall aero package, with the difference between the minimum and maximum cooling packages accounting for up to five per cent of the total downforce. However, there is a constant trade off between aerodynamic drag and engine performance, with a 5degC increase in engine temperature reducing the power output by approximately one bhp.

**COOLING OPTIMISATION**

Before track testing in F1 was restricted, assessment of cooling systems could be completed either in wind tunnels or trackside. The reduction in time available to test cars has seen overall aero package testing take centre stage, to the detriment of other areas of development, such as cooling optimisation. As one F1 engineer put it: 'generally we have very limited (or no) time within our "aerodynamic" wind tunnels for coolant system development'. This has meant teams have had to outsource some of the testing for cooling components, utilising companies such as Young Calibration, who offer thermal and aerodynamic testing of water, oil and charge coolers. *Racecar Engineering* visited the company's UK facility to see what was involved to ensure coolers performed to their maximum potential.

Young's facility sports two wind tunnels - a closed loop system designed for testing individual cores and an open-ended tunnel for testing coolers installed in nose or sidepod sections. The combination of the two allows engineers to

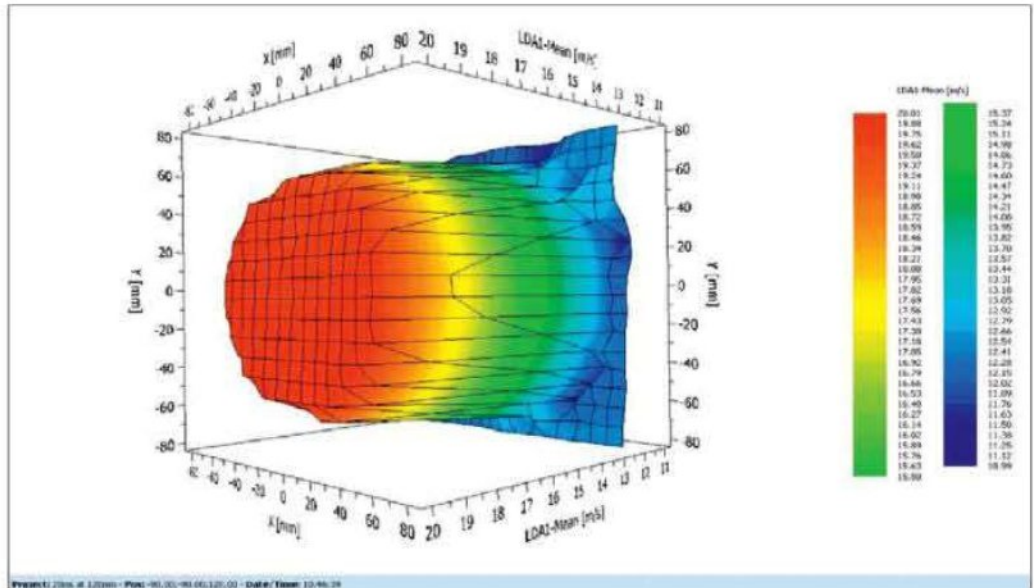

LDA provides an image very similar to that produced by CFD simulation, however, it is generated using physical data making it ideal for confirming simulated results.

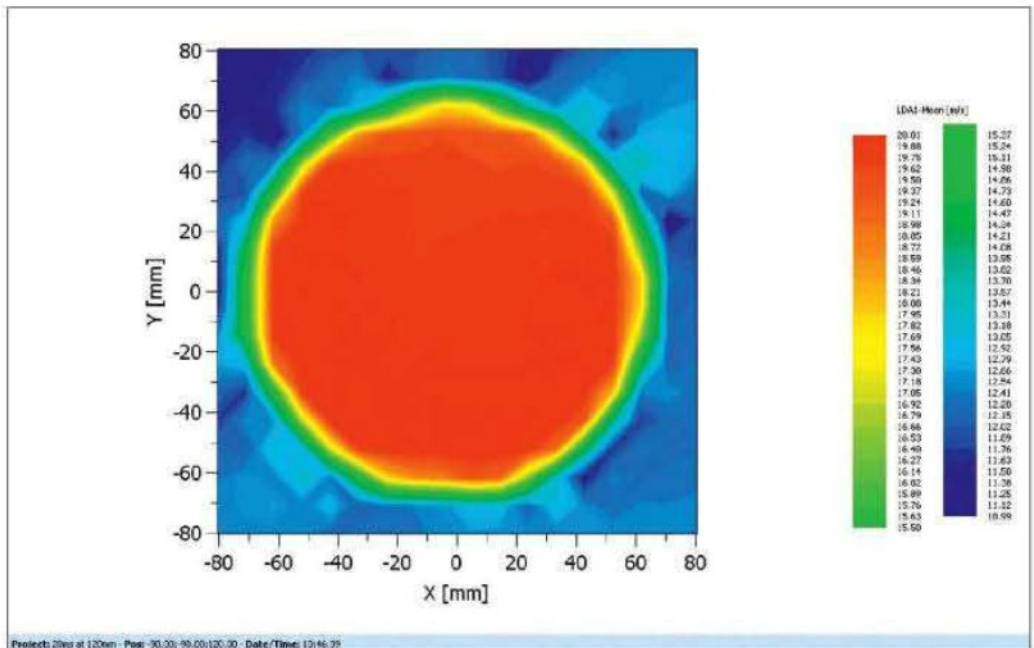

Laser Doppler anemometry (LDA) is used to gain a visual insight in to the airflow performance of a cooler core, highlighting potential flow restrictions.

assess both the thermal and aerodynamic properties of radiators, as well as undertaking rapid back-to-back testing of different designs, something that is rarely practical under track testing conditions.

**THE TEST PROCEDURE**

To test coolers, the units are mounted on either a suitable template, or enclosed within a sidepod or nose before being attached to the tunnel test section. The laboratory at Young Calibration is equipped with a 300Kw boiler to provide high temperature coolant to the

radiator cores. A boiler of this capacity is required due to the high levels of heat rejection in a modern race engine, with the current 2.4-litre F1 motors transferring anywhere up to 230Kw of heat into the coolant. Normally, Young is able to run both of its test sections simultaneously but, in exceptional circumstances, the entire boiler supply can be routed to one test rig. The majority of testing takes place in the open-ended tunnel, which can accommodate a full size single seater and is capable of generating air velocities at the radiator face equivalent to race

speeds of 190mph.

The key tools for assessing the cooling efficiency of a core are a number of temperature sensors placed at the inlet and outlet of the radiator, together with Pitot tubes to measure the inlet and outlet airflow. As temperature controlled flow air is passed over the outer 'finned' surface of the radiator, a temperature controlled flow of fluid is passed through the internal tube passages. The system is then run through a predetermined test matrix of differing load and air speed conditions, with the level of heat dissipation derived for each

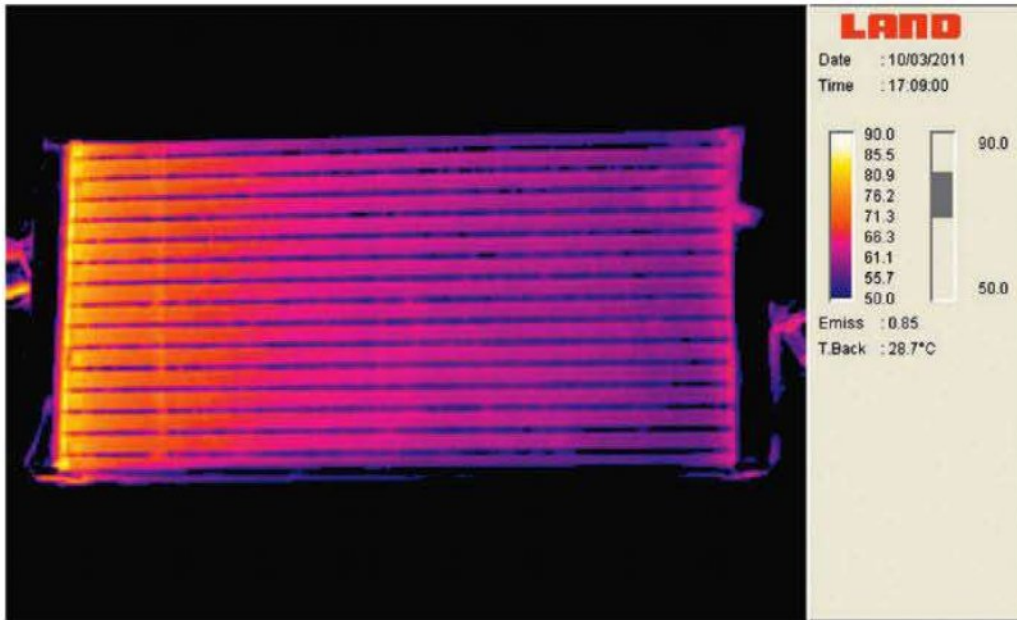

Thermal imagery is used to rapidly check for hot and cold spots on a core, meaning that potential blockages or flow restrictions can be identified quickly.



Young's open section tunnel with a Mezzo Technologies IndyCar cooler installed in a complete Dallara side pod. The open section tunnel allows for rapid testing of multiple design iterations

condition. If cores are tested in isolation, without being mounted in sections of the vehicle, the closed loop wind tunnel can be used.

This system allows for the level of heat gained into the air stream to be calculated and a heat balance obtained, in order to double check data gained from simulation. Depending on the type of installation, up to 64 different channels of data can be logged with data acquired during track testing, dictating the

temperatures, flow rates and air velocities used.

#### LASER DOPPLER ANEMOMETRY

Beyond the basic measurements of inlet and outlet coolant temperatures and airflow velocities at the cooler face, Young Calibration has also started to use Laser Doppler Anemometry (LDA) and thermal imagery to provide visualisation of core performance. The use of thermal imaging cameras gives

a clear indication of surface temperatures on core, allowing for hot and cold spots, or blockages to be identified quickly. Meanwhile, LDA allows for detailed analysis of air velocity over the cooler, by measuring the direction and speed of fluids using lasers and 'tracer' particles in the test fluid. In its simplest form, LDA crosses two beams of collimated, monochromatic and coherent laser light through the fluid under test. The beams are normally obtained by splitting

a single beam, to ensure the beams remain coherent. These are then intersected at their focal point, where they interfere with each other, creating a set of straight fringes. The lasers are aligned perpendicular to the fluid flow and, as the tracer particles pass through, they reflect the light into a photo detector. Through measuring the Doppler frequency shift of the light, it is then possible to calculate the velocity of the tracer particle, and from that the velocity of the fluid. The end product of this process produces an image very similar to that created during a CFD simulation, but derived from actual test data. As with the thermal imaging, the process allows for a very rapid assessment of the flow characteristics of a particular installation. Changes can then be made and re-assessed to determine the most effective method of installation.

#### CONSTANT EVOLUTION

Like all areas of race car engineering, cooling system optimisation is constantly evolving, with a host of factors coming into play. One of the most notable of these is the effect of cost cutting in Formula 1 and other series, where previously teams replaced coolers as a matter of course after each race. Cost constraints have seen them extending component life and Young Calibration says it has seen an increasing number of used cores coming through the doors to be re-tested for performance drop off. The re-introduction of KERS has also placed greater demands on cooling capacity, with energy recovery systems running a further dedicated cooling system, again which need testing and assessing. The ability of teams to outsource this work frees up valuable testing time in teams' own wind tunnels. No doubt the increased use of smaller capacity, forced induction engines throughout motorsport will place even greater demands on cooling systems, and services such as those provided by Young Calibration will be increasingly called upon by teams seeking to maximise their available resources.



# Brave new world rally cars

## part 2

As the World Rally Championship continues its renaissance, the second part of our report on the latest World Rally Cars details Citroën Racing's budgeted-to-win DS3 and Prodrive / BMW's MINI John Cooper Works

BY MARTIN SHARP

One to watch - the new MINI Countryman WRC. With an engine by BMW Motorsport and preparation by Prodrive, it definitely packs a punch



**D**espite the tight technical regulations governing the latest breed, each of the three new WRCs to have appeared so far exhibit notably different concepts. Influencing this is the FIA dictat that a manufacturer must be registered for the World Rally Championship and must homologate a Super 2000 version of its chosen model before it can have a World Rally Car version approved. The theory runs that a customer could run an S2000 one weekend and a WRC the next. While the

each of the three new WRCs to have appeared so far exhibit a notably different concept



Pictures LAT

With a very limited development period, design and construction of the Citroën DS3 WRC was necessarily rushed, something that wasn't helped by the team's decision to build a new engine from scratch

inherent operational flexibility disadvantages to this, it carries the overriding advantage of a single goal and a scale of budget to achieve it. By contrast, Prodrive is a commercial operation, charged by BMW with achieving the same aim.

Based in a purpose-built facility at Satory, near Versailles, the vast majority of Citroën Racing's technical developments are undertaken in house, although the team uses specialist suppliers for brakes, dampers, and clutches. Suppliers are not certain exactly which of their parts are used in the cars, nor

for the engine and for the software. We had maybe 14 or 15 months to design an engine, build and test it on the bench first, then July / August for the first tests on the car. Then we must buy all the parts for the next season [2011] in September / October just after we start the tests with the car. That's the main problem, but it's the same for everybody.

'I'm just afraid that someone will find something better than the others - maybe because they are just lucky - and then they will have a better engine. There's not a lot of time and you

## Citroen Racing is the only wholly manufacturer-owned rally team in the WRC

essential differences between the two are just their aero kits, flywheel weight and side glazing material, each team has adopted a different approach.

Citroën Racing stated early on that it would not build a Super 2000 car and chief engineer, Xavier Mestelan-Pinon, remains clear on how he intends to homologate his DS3 WRC: 'If I want to homologate my car, I just homologate a World Rally Car with a wing and a new front bumper, to be clear with the S2000.' Later, he added: 'I don't want to speak about S2000. It's quite simple, I design a World

Rally Car for 2011.'

Over in the MINI camp, Prodrive couldn't contest enough events with the MINI rally car this year to qualify for championship registration, but a solution was found when Daniel Oliveira, a Prodrive / MINI customer, agreed to enter a car on a sufficient number of events to satisfy the FIA criteria.

### CITROËN DS3 WRC

Currently, Citroën Racing is the only wholly manufacturer-owned rally team in the WRC. It designs, builds and runs its cars. While there may be some

how much they have been further modified.

Under these favourable conditions, Citroën engineers, under the guidance of Mestelan-Pinon, have consistently produced highly competitive rally cars. In the past, however, they made time for themselves to develop the machines, while today's new regulations have forced an unusually short development timescale on the team, as Mestelan-Pinon explained last year: 'We don't have enough time, that's the problem. That's why for the first season we need to have jokers

cannot test many different sorts of adjustment - for example, the positions of the direct injectors.'

That's not helped perhaps by the fact that Mestelan-Pinon chose to design and build the DS3 power unit from the ground up, with a new block and head: 'Big work, very difficult, and it will cost - but at the end, because of the reliability, it will be very good,' says the Citroën engineer.

'We started from a blank sheet of paper around one year ago because of the regulations. The block is aluminium alloy, as is the head, and they are unique, as is the injection.'



TECH SPEC

**Engine:** Citroën Racing 1.6-litre direct injection, four-cylinder in-line turbo engine; aluminium cylinder block; steel crank; aluminium DOHC cylinder head, four valves per cylinder; indirect injection controlled by Magneti Marelli SRP-HP unit  
 Bore: 82.0mm, stroke: 75.5mm  
 Garrett turbocharger (with FIA mandated 33mm restrictor)

**Power:** 300bhp at 6000 rpm  
**Torque:** 350Nm at 3250 rpm

**Transmission:** permanent four wheel drive; mechanical, auto-locking limited slip differentials front and rear with a clutch disconnect; Sadev six-speed sequential gearbox with mechanical shift

**Suspension:** Citroën Racing MacPherson struts front and rear, four-way adjustable dampers; front and rear anti-roll bars

**Brakes:** Front brakes Tarmac: Water-cooled, four-piston calipers with 355mm diameter ventilated discs  
 Gravel: Water-cooled, four-piston calipers with 300mm diameter ventilated discs  
 Rear brakes Tarmac and gravel: four-piston calipers with 300mm diameter ventilated discs

**Steering:** Hydraulic power-assisted rack and pinion

**Wheels and tyres:** 8 x 18in diameter (tarmac), 7 x 15in diameter (gravel and snow); Michelin tyres (FIA regulations)

**Bodyshell:** Citroën Racing DS3, steel and composite bodywork, welded, multi-point roll cage; WRC rear wing; WRC front bumper

**Dimensions:**  
 Length: 3948 mm  
 Width: 1820 mm  
 Wheelbase: 2461 mm  
 Track: 1618 mm (front and rear)  
 Fuel tank: 75 litres  
 Weight: 1,200 kg, including driver/co-driver (FIA regulations)

Had Mestelan-Pinon made any iterations of the engine before this season began? 'No, how can I?' he responds. 'I don't have the time. We started the first tests on the dyno in April [2010], and the first tests in the car in August. Since the beginning, I have done about 5000km testing with the new car - initially, I had the 2.0-litre [detuned, from the C4 WRC] but, with the new engine, maybe only around 1500km.'



Outwardly similar to that of the outgoing C4, the DS3's suspension and brakes comprises Citroën Racing's re-engineered components, while the gearbox with its rear drive disengage unit, is a joint venture with Sadev

SUSPENSION

Ball or roller bearing MacPherson struts are not allowed in the new WRCs, just DU bushes, but essentially the DS3 suspension is similar to that of the previous C4 WRC.

The entire system is described correctly as a Citroën Racing design, although it is highly likely the team is modifying Extreme Tech damper components, possibly together with some BOS equipment.

The situation is similar for the brakes: Citroën Racing designs, based on Alcon components, which feature 355mm diameter discs at the front for tarmac and 300mm at the front for gravel, with 300mm at the rear for all surfaces. The front four-piston calipers are water-cooled for use on tarmac.

For the transmission, Mestelan-Pinon requested Sadev to produce units to his design for the homologated Sadev unit, with its pump-driven, rear drive disengage unit. In principle, he is not in favour of the centre diff ban: 'It's very stupid. Because of the regulation, we cannot choose a central diff, but when you pull the handbrake you must disconnect the rear axle, so you must have something like a centre diff to disconnect the axle. It isn't right.'

He points out that the ban on

titanium and magnesium makes it more difficult to achieve the weight limit, and that, 'With the gearbox, for stiffness [aluminium] is okay, but maybe it's too hard for when you have a shock. magnesium is more resilient.'

Current WRCs are based on B segment cars, which are generally narrower in the cockpit than the outgoing, C segment-

except for the Audi R8. All other road car injectors simply don't have enough flow for our conditions. Magneti-Marelli try to do some injectors, but they've just started, so I don't want to work with them.'

With its six-speed gearbox and potentially more than 300bhp from its 1.6-litre turbocharged engine, the Citroën is clearly

the ban on titanium and magnesium makes it more difficult to achieve the weight limit

based World Rally Cars and, as in the C4, Mestelan-Pinon has strengthened the DS3 door sills with 4.5kg of extra material per side to aid protection in a side-intrusion accident.

The unique engine in the DS3 requires a different wiring loom, but the ECU is the same as that in the C4, while the power controller is new - again, a Citroën Racing development. On the fuel injectors for the direct injection system, the team has worked closely with Bosch Motorsport. 'It's difficult to find an injector with the right flow because of the power of the engine,' explains Mestelan-Pinon: 'Nobody else has an injector,

capable of keeping up with the Ford. Results so far have pretty evenly spread between the two rival marques - Fiesta RS WRCs dominated in Sweden, Loeb's DS3 won in the high altitude Mexican event and the two works Citroëns came in first and second in Portugal, with the works Fords third and fourth. With one third of the season complete, the manufacturers' and the drivers' standings do not show a clear favourite, and the battles between Ford and Citroën, Mikko Hirvonen with Sébastien Loeb are evenly matched.

May's Rally of Italy in Sardinia, which saw the manufacturers enter equal on points, was the



# known from pole to pole

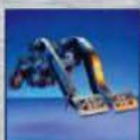

## The mark of success

For over 50 years, AP Racing have unerringly supplied state-of-the-art clutches, brakes and associated products to race teams around the globe, clocking up hundreds of pole positions, podium finishes and over 650 GP wins in the process.

This remarkable track record has been built on the solid foundations of sheer technical engineering and design know-how.

This knowledge stems from their in-depth study of the science of friction carried out at their R&D facilities in the UK – a place where innovation and reliability have become watchwords.

And this is why the name AP Racing has become synonymous with the front of the grid, in every formula, worldwide.

*If you'd like to know more, contact AP Racing's technical sales team.*

AP RACING  
WHEELER ROAD  
COVENTRY CV3 4LB  
ENGLAND  
TEL +44 (0)24 7663 9595  
FAX +44 (0)24 7663 9559  
EMAIL: sales@ap racing.co.uk

[www.ap racing.com](http://www.ap racing.com)

the science of friction





The MINI rallied in Portugal In Super 2000 form but made its WRC debut in Sardinia

first event after free engine spec modifications expired [and FIA data logging is in force on the cars].

**MINI JOHN COOPER WORKS**

The Rally of Italy also saw the debut of the MINI WRC. Prodrive, of Banbury, UK, is steeped in rallying history, and returns to BMW with the new programme.

The MINI WRC has an engine based on the BMW World Touring Car Championship unit, but modified extensively for rallying in Munich after recommendations from the 'Banbury Boys'.

Uniquely, two MINIs first rallied as 2011 Super 2000 cars on the Rally of Portugal, equipped with 30mm diameter restrictors (as opposed to the 33mm diameter restrictors on the 2011 1.6-litre turbo S2000 cars). The first was a JCW MINI S2000, which was driven by Andrea Navarra in the Rallye dell'Adriatico, the first round of the Italian gravel championship early in April. Run by the Grifone team, the car won the event by 12.6 seconds.

The 33mm-restricted S2000 MINIs went well in the WRC round in Portugal too, though drivers Oliveira and Armino Araujo complained of a lack of high-speed stability due to the reduced downforce provided by the non-WRC aero kit, proving the MINI should by no means be discounted as a World Rally Car.



A marketing department's dream - the BMW MINI played on the rallying heritage of the original Mini, though similarities are limited, at best

Racecar Engineering has already covered the basics of the Prodrive MINI WRC concept, but here's a quick re-cap. When Subaru pulled out of the WRC in December 2008, Prodrive had to re-group.

In early 2009, a small core of engineers came up with a generic concept for the 'ideal World Rally Car', assessing the potential of forthcoming models from different manufacturers. The cars were modelled for

competitiveness, based on dimensions, power, grip, c of g, weight distribution and so on.

At the same time, former-Xtrac and Suzuki Sport engineer, Paul Eastman, working under the experienced Prodrive technical director, David Lapworth, headed a group of three design engineers whose task was to come up with the CAD data, using suitable production cars as the basis for WRC contenders.

**COUNTRY FOLK**

Then the BMW MINI Countryman came along. It not only fitted the model, it appealed to the marketing men who could play upon the old MINI rallying heritage. Prodrive boss, David Richards, got BMW interested - not least because the German manufacturer was committed to a 1.6-litre turbocharged engine for its WTCC programme.

The deal was authorised in October 2009, and agreed in December, with BMW to provide engines. After BMW's motorsport director, Mario Theissen, and his engineers had verified the quality of the work done at Banbury, it was agreed that Prodrive would engineer and build the rest.

Specific design of the MINI Countryman WRC took place between January and September 2010, with a test car built between May and August. The first test was on September 1, with a gravel test in Portugal two weeks later. Production began in October, with the first complete WRC MINI ready in January of this year, with customers in February and homologated for S2000 in March.

Eastman is adamant that the MINI WRC's design is cohesive, not least because it is the product of three design engineers only, working from the same office. Their brief was to keep the cost of competing with the car to the minimum, which is why the design of key front and rear suspension components such as anti-roll bars and links, are identical. Similarly, sole suppliers have been chosen for entire systems - German company Continental producing the whole fuel system, for example. This particular tactic saved 6kg and a third of the cost over the system employed on the Prodrive Subaru.

A priority for the development team was the efficiency of the car's rollage. In comparison with Prodrive's original virtual model of the ideal WRC, the weight distribution, c of g and dynamic index of the MINI is within one per cent of that ideal. The Countryman bodysell may be between 30kg and 60kg heavier than that of its rivals but, as Lapworth observes, 'The rigidity of the standard 'shell is excellent,

teams have five 'jokers' to deploy this year, which will almost certainly be used to address reliability issues

# Experts in analysis.

Racing smart means knowing all about the performance of your vehicle and driver. Get the complete picture with integrated data and video solutions from MoTeC - developed with professional teams worldwide and supported by our global dealer network.

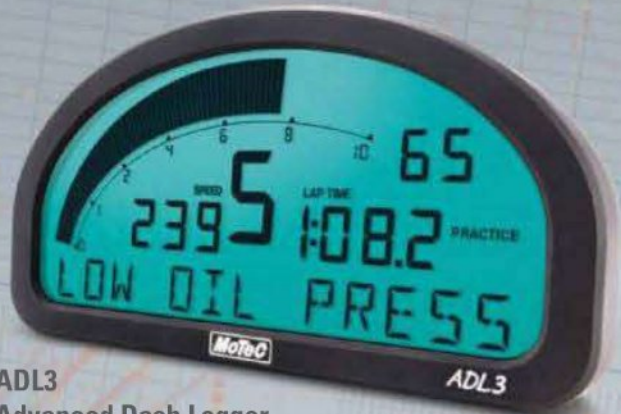

## ADL3 Advanced Dash Logger

Programmable display, logger and controller in one. Up to 250Mb logging memory, fast ethernet download, advanced maths, two independent CAN buses and an internal 3-axis G force sensor.



## VCS Video Capture System

Solid state digital recorder specially designed for motor sport with programmable Auto Start/Stop, selectable gauge sets, CAN connectivity, 4GB or 16GB, USB download and 12 V power.

Watch our training webinars online - quick, convenient, free!



**Race smart.**  
www.motec.com

# KRONTEC

Fitting & Hose Systems

## ...one step ahead



### High quality hose assemblies

- All race series F1, ALMS, WTCC, WRC
- 100% pressure tested
- flushed to NAS on request



### Airjack system - quick lift

- Most lightweight - only 962g at 230mm stroke
- fastest actuation - by 40bar pneumatic pressure
- Highest safety - by integrated pressure relief valve



### Steering wheel quick release

- Only 272g
- Conical seat - free from play
- Easy to connect by ingenious mechanism



### Bespoke parts

- CNC turning and 5-axis milling machines
- short delivery times
- full traceability



### NEW online shop

- delivery from stock
- easy order system
- worldwide delivery service

## New facility in the UK

KRONTEC Design Ltd., Phone: +44(0)17 93-42 20 00

www.krontec.com

which allows us to adapt the design of rollcage easily and to maintain 'shell weight at the minimum possible.'

Prodrive has concentrated on the critical area of crew protection in side impacts. Sessions with the boss of the FIA Institute's Closed Car Group, Andy Mellor, came up with the concept of running the MINI's rollcage side bars *outside* the car's b-pillars - an idea that has been approved by the FIA and is currently under assessment for future applications. Effectively, the side bars run between key 'cage / 'shell stress areas, outside of the b-pillars and through the doors, providing the additional advantages of releasing more space for the crew inside and, it

is said, improving deformation protection by increasing the space between crew and the protection equipment.

### DEVELOPMENT WORK

Like its WRC rivals, the MINI's engine is canted rearward by the maximum 25 degrees. Its intake manifold faces rearwards, while the exhaust faces forwards. Logically, the turbo is low and, by configuration, must be at the front, between the engine and the cooling system.

Bosch fuel injectors now seem to be the current choice for all current 2011 World Rally Cars.

Communication between Prodrive and the BMW engine engineers is good, Eastman citing how this was of benefit

when it came to harnessing Prodrive's experience with dry sumps: 'The first one they sent us was too big to fit in the MINI. We used our system, which the BMW engineers then worked on adapting for the WTCC!'

The JCW MINI WRC uses Prodrive-developed Öhlins dampers, and Lapworth explains that it is on the dampers and suspension design where the team has worked most:

'We separated elements that could be part of long-term development from those that needed to be absolutely correct at the beginning - things like grip, c of g, unsprung masses, aerodynamics, the 'shell and the basic suspension design. We concentrated our work on these

points because they form part of the homologation of the vehicle.

'On the other hand, things like the ease of using the engine and suspension settings are areas on which we can continue to work indefinitely without problems.'

Whether all the work pays off will become clearer during the season, but on paper at least, the combination of BMW and Prodrive should make it a very strong contender indeed. 

## DRIVE TALK

Despite new rules outlawing central differentials on World Rally Cars the sport's governing body, the FIA, has understood that drivers need to negotiate tight hairpin bends as swiftly as possible - preferably in spectacular fashion to entertain fans. So to facilitate this, they have allowed rear-drive disengagement mechanisms.

Put simply, the driver arrives at a tight bend and yanks the handbrake. The car's engine then sends power to the front wheels only, the handbrake locks the momentarily undriven rear wheels, the car swings into oversteer and the hairpin is negotiated neatly - and spectacularly. Once round, the driver plants his right foot, all-wheel drive cuts back in and the car rockets away.

The FIA's technical chief, Jacques Berger, is adamant that such systems must be 'on-off' only, adding that he is convinced that any attempt to get such friction-based clutch-engagement equipment to slip would break it.

Each of the two homologated transmission systems for the latest WRC cars use clamping friction clutches to effect this rear-drive disengagement. Both the Fiesta and the MINI are fitted with an Xtrac system with

an extra mechanical hydraulic master cylinder, activated by the handbrake, to effect the disconnect, while Citroën has employed the homologated Sadev arrangement, which uses an electrical switch to activate hydraulic pressure to disengage.

It remains a physical law that a slipping transmission friction clutch reduces torque supply to the wheels, which can only mean less propulsion - if traction is available. Wheel traction depends on surface and tyre condition, and vehicle

allowing the driver to keep his right foot planted. This might explain the apparent evidence of Citroën co-drivers deploying the handbrake at what can be called 'non-hairpin situations'...

There is also the potential advantage that there could be less torque being delivered to all four wheels by virtue of a minimally slipping rear-drive disengage clutch, so the front wheels won't over slip either.

And there may be some advantage to less torque being delivered to *all four* wheels by virtue of a - minimally - slipping rear-drive disengage clutch, in order that the front wheels won't proportionally overslip.

The rear-disengage is mechanical, there are no clutch slip time rules in the regulations nor stage position handbrake application restrictions. Electronic management of chassis control is banned, and in this hypothetical situation is not required.

The FIA's electronics expert, Silvain Riviere, closely monitors the data logged from all current WRCs at each rally. Data taken over the first three 2011 events was used to establish realistic parameters of operation, with the objective of arriving at such parameters at the time engine modification restrictions came in at the end of April.

## Electronic management of chassis control is banned

dynamics dictate that the most effective driven wheels when accelerating are at the rear, where much of the mass is transferred. In this situation, if the rear tyres are spinning away merrily, momentarily removing a certain amount of drive torque to generate some 'dig' from them can enhance traction and forward propulsion while

## TECH SPEC

**Engine:** 1.6-litre direct injection, four cylinder in-line turbo engine developed by BMW Motorsport / Prodrive; aluminium cylinder block with bed plate lower section; steel crank with reduced bearing diameters; steel con rods; forged skirt pistons; aluminium DOHC cylinder head (four valves per cylinder); motorsport flywheel Bore: 77.0mm, stroke: 85.8mm; Garrett turbocharger (with FIA mandated 33mm restrictor); max engine speed 8500rpm (FIA regulations)

**Power:** approx 310bhp  
**Torque:** approx 420Nm

**Transmission:** permanent four-wheel drive; plated (mechanical) limited slip diffs front and rear with a clutch disconnect; Xtrac six-speed sequential gearbox with mechanical shift

**Suspension:** Öhlins / Prodrive MacPherson struts, three-way adjustable; front and rear anti-roll bars

**Brakes:** tarmac - AP Racing four-piston calipers with 355mm ventilated discs; gravel - AP Racing four-piston calipers with 300mm ventilated discs

**Steering:** hydraulic, power-assisted rack and pinion

**Wheels and tyres:** ATS wheels, 18in diameter (tarmac), 15in diameter (gravel); FIA regulation Michelin tyres

**Bodyshell:** MINI Countryman with Prodrive rollcage exceeding FIA regulations; WRC rear wing; WRC front bumper

**Electronics:** Cosworth chassis and engine data acquisition for on-event diagnostics and performance development

**Dimensions:**  
Length: 4110mm  
Width: 1820mm  
Weight: 1200kg (FIA regs)

# Öhlins ready for takeoff in WRC



Öhlins are proud to partner the MINI WRC Team. For more information about our complete Rally range, please contact Öhlins Racing UK.



Öhlins Racing UK - Chris Witter +44 (0) 203 286 3127  
chris.witter@ohlins.se

Öhlins Racing AB - Office: Instrumentvägen 8-10  
Box 722 SE194 27 Upplands Väsby - Sweden



# CORYTON

advanced fuels

**Coryton Advanced Fuels are pleased to announce supply of control fuel to Superleague Formula for 2011**



- Manufacture and supply of race and control fuels to motorsport specifications such as FIA, FIM etc
- Supply to Karting, historic series, circuit, rally and FI from our industry-leading fuels manufacturing plant
- Fuels designed and optimised for power, fuel economy, durability and climatic requirements
- Flexible packages available, including logistics and trackside support, backed by fast turnaround times and excellent customer service

For more information contact:  
**Telephone: +44 (0)1375 665701**  
**E-mail: sales@corytonfuels.co.uk**  
**Web: www.corytonfuels.co.uk**





# Fuel for thought

What will power the competition vehicles of the next 20 years?  
We look at the current state of play and do a little crystal -ball gazing

**M**otorsport fuels - it's a contentious subject in this time of heightened environmental consciousness. Should the sport continue to use carbon-based fuels? If not, what other options are available? Should motorsport be used to develop and prove out future technologies that will be relevant to the automotive manufacturers? In short, what is likely to power the competition vehicles of the future?

We took these questions to Coryton Advanced Fuels. As the name suggests, it is based at the huge, former BP refinery complex near Coryton, Essex, on the Thames estuary. BP sold off the main refinery to Petroplus in 2007, but retained the specialist - and standalone - blending plant within the complex. It then decided to sell that part of the operation in late 2009, and it was acquired by a small group led by Dr Craig Goodfellow and Diane Lance, who subsequently set up

Coryton Advanced Fuels.

Goodfellow and Lance are highly qualified chemists, who have worked at both BP and Ricardo during various times in their extensive careers in the fuels and lubricants industry. When the opportunity arose to acquire the blending plant, however, and set up their own specialist company, they seized it. Now they - and their business partners - are owners of an independent facility whose primary product areas are motorsport fuels, specialist test fuels and reference fuels. Interestingly, the plant has a history under BP ownership of supplying fuels to leading Formula 1 teams, and for that reason, CAF is represented on the Formula One Fuels Advisory Panel (FOFAP).

The blending of motorsport fuels is projected to form 40 per cent of Coryton Advanced Fuels business, so it is an area of major commercial involvement for Goodfellow and Lance.

The obvious starting point for questioning has to be with the currently most prevalent liquid carbon fuels themselves - gasoline and diesel. 'The first point to make, I think, is that liquid hydrocarbon fuels will be here for a considerable time to come,' observes Goodfellow. 'The internal combustion engine will still be the dominant source of power for transport not just in 10 years time, but also 20 years time. It is, despite some of its failings, still a very efficient way of propelling vehicles, and emissions through

**liquid hydrocarbon fuels will be here for a considerable time to come**

the tailpipe are well controlled through via catalytic converters. The main issue is around the sustainability of carbon.

'There's still a lot that can be done with the internal combustion engine. If you talk with companies like Ricardo and the other consultancies, there are some significant benefits still to be had through more radical downsizing, the use of boosting technologies, the use of waste energy recovery.'

Such reduced capacity, turbocharged, high-performance power units have already arrived in motorsport with the adoption by the FIA of the so-called 'Appendix' engines, in use in this season's WTCC and WRC cars. 'If we consider future engine technology, for the gasoline market, it's really going in one direction, and that's the downsized, boosted route,' says Goodfellow. 'It means engines will become smaller, they will have a higher specific power rating and

### Coryton Advanced Fuels Blending Plant

**Description:** independently owned, secure facility that offers flexibility to blend, store and transport varying volumes of fuel, from 5 litres to 1 million-plus litres

**Built:** 2000-2001

**No of employees:** currently 10

**Main products:** motorsport fuels, specialist test fuels, reference fuels

**Operational capacity:** currently approximately 4 million litres throughput of fuel pa

#### Storage and blending capacity:

- 60 liquid hydrocarbon storage and blending tanks
- Total tank storage volume 2.5 million litres
- Individual tank capacities from 5000 litres to 100,000 litres
- Bespoke drum storage capacity 2000 x 200 litre drums
- Propane/butane pressurised storage vessels x 2

**Transport:** loading and dispensing for fuel road tankers, isotainers etc



Coryton Advanced Fuels has a range of advance blending equipment including this automated distribution analyzer, used primarily for atmospheric distillation

run at higher average cylinder BMEPs. This means the fuel properties are likely to become more important because the engine will spend more of its time at high relative loadings.

'We therefore believe that things like octane number can start to become more important again. If you run an engine at very high loadings, very boosted, you have to ensure there is no detonation, so the anti-knock properties of the fuel start to become more important, as do parameters such as latent heat of evaporation of the fuel - if you like, the charge cooling properties of the fuel - in terms of preventing knock by keeping the charge cool, but also improving volumetric efficiency. We also believe that calorific value of the fuel is important, so as you are increasing oxygenation in the form of bio components in the gasoline, you are reducing the calorific value of the fuel, and that increases the volumetric fuel consumption. There are a number of parameters within the fuel that are likely to impact on the overall fuel consumption, efficiency and performance of the next generation of downsized engines.'

And what about the gasoline blends that incorporate bio fuel elements? 'I think until now there have really been just one or two available gasoline bio fuel components, and that's ethanol or ETBE,' says Goodfellow. 'ETBE is made from bio-ethanol, and up until this point, there has really been one predominant route

through to bio-ethanol, which we call first-generation bio-ethanol and comes from either corn fermentation - starchy crops - or sugar crop fermentation. One of the issues about first-generation bio-ethanol production is that the bio credentials are not as good as you might think, in some cases, although crops like sugar cane are much better. Really, the focus is to move to so-called second-generation processes where you're looking to use the whole of the plant crop yield.

'There is one caveat, and that is a number of companies are all working on another molecule,

**some of the latest bio components naturally have very high octane numbers**

which is based on butanol. The advantage of butanol is that it is less oxygenated, so it gives you better fuel consumption, it has reduced corrosion incompatibility for engine components and is a better way of getting more bio-carbon into the fuel.'

Interestingly, the new smaller, boosted engines, by their nature, can benefit from fuels with a higher octane rating, and this may play to the arrival of some of the latest bio components that are

coming into the market, as they naturally have very high octane numbers. 'If you take ethanol, for example, it has a very high octane number, much higher than conventional gasoline,' observes Goodfellow. 'So there is a possibility of introducing more bio components and increasing the octane number at the same time.'

One subject that inevitably arises when discussing the future of fuels and motive power is fuel cells. 'You know, they're always just around the corner, and they have been for a couple of decades.' That's not to say they won't come, and there are a lot of advances being made on technology, particularly, for example, bringing down the precious metal requirement in fuel cells, which is one of the keys to reducing the cost of them by maybe an order of magnitude that is probably necessary to make them competitive.

'You also have issues about what fuels you run fuel cells on. People originally started talking about hydrogen, then diversified away to look at liquefied fuels, such as methanol, even naphtha, that could go through a reformer and then be used in a fuel cell, but gradually, as these technologies have been explored, each has come up with its own disadvantages. We therefore seem to keep coming back to hydrogen, and it being the most likely way forward, and that then begs the question of how you put a hydrogen structure in place in order to supply a mass market.

'There are routes through, but there is always a problem with either the quantity of hydrogen you can make through a specific route, or the cost of making it via that route, or the capital requirement of putting the equipment in place to make it via that route, or even the efficiency. Everywhere you look, there is a barrier, and even at this point in development, you still need a breakthrough in one of those core areas of technology to change the market significantly.'

Finally, one interesting area for the future may be algae-based fuels, one of their major attractions being that the base plant material could be produced in semi-arid areas or in areas of poor soil, which would not normally support food production.

'There was a lot of interest in the 1990s in algae, mostly from the US in the context of energy security,' says Lance. 'There are a lot of nice things about algae. You can do it in either open pond or closed reactor, you can co-feed it with CO<sub>2</sub>. It's a case of watch this space. It might be something for the future.'

[www.corytonfuels.co.uk](http://www.corytonfuels.co.uk)



# Them's the brakes

This month Alan Lis delves into the high-stress world of discs, pads and brake dynamics

part 2



temperature on the friction surfaces spike to over 1000degC

Every September, the Italian Grand Prix presents the Formula 1 brake manufacturers with their toughest test of the year. After accelerating out of the Curva Parabolica, the cars reach terminal speeds of well over 200mph as they pass the pits. Moments later, the drivers apply the brakes, 120m from the Variante del Rettifilino, and the cars are slowed by more than 130mph in 2 seconds before they turn into the first part of the chicane. During this retardation, the temperature on the friction surfaces of the cars' carbon-carbon brake discs and pads spike to over 1000degC. At the start of the race the brake discs fitted to the cars are 28mm thick, by

the end of the race they will be 20mm thick, or less. In extreme circumstances the discs will actually have worn to the extent that there will be holes in their faces where radial ventilation apertures have broken through because the friction surface has been completely abraded. This is a pad eat disc world.

There are currently three suppliers of carbon-carbon (carbon fibre-reinforced carbon) brake material in the F1 market - Carbone Industrie - Hitco and Brembo, which is the distributor of material made by Honeywell. Each of the materials has slightly different characteristics.

#### MATERIALS TECHNOLOGY

'At one extreme you have the

Carbone Industrie material, which is very three dimensional and fairly temperature sensitive, while at the other you have the Hitco material, which is two dimensional and very temperature stable,' explains AP Racing's Steve Bryan, whose company's brake system components must cater for all carbon-carbon options. 'In the middle, you have the Brembo material that tends to be run as a combination of a 3D disc and a 2D pad, which gives a degree of the best of both worlds, but that combination tends to lead to a higher wear rate.

'Hitco's material has a primarily 2D construction in which the fibres are laminated and there's a certain amount of pitch fibre in its composition. Of

the three materials it's seen as the most user friendly because it works well from relatively low temperatures.'

The carbon-carbon manufacturing process is time intensive. The transition from the initial processing of raw fibres to the finished brake disc or pad can take as much as eight months, including periods of weeks in high-temperature furnaces (see *Racecar Engineering* V9N9). For the manufacture of its discs Hitco has developed a patented method of creating vent holes. Sacrificial moulded cores are inset into the discs as they are being made up so they are sandwiched in the carbon when it is pressed. When the discs go into the furnace, the cores melt away leaving

The Variante del Retiifilo at Monza provides the Formula One brake manufacturers with the sternest test of their products

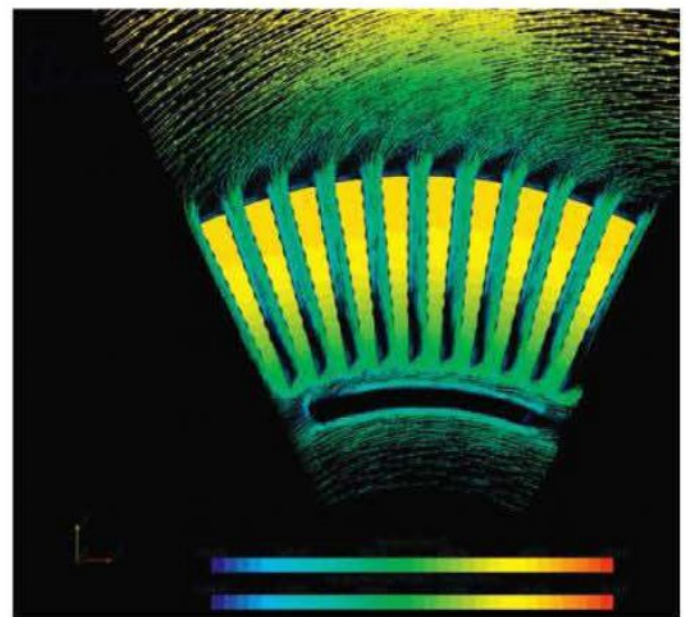
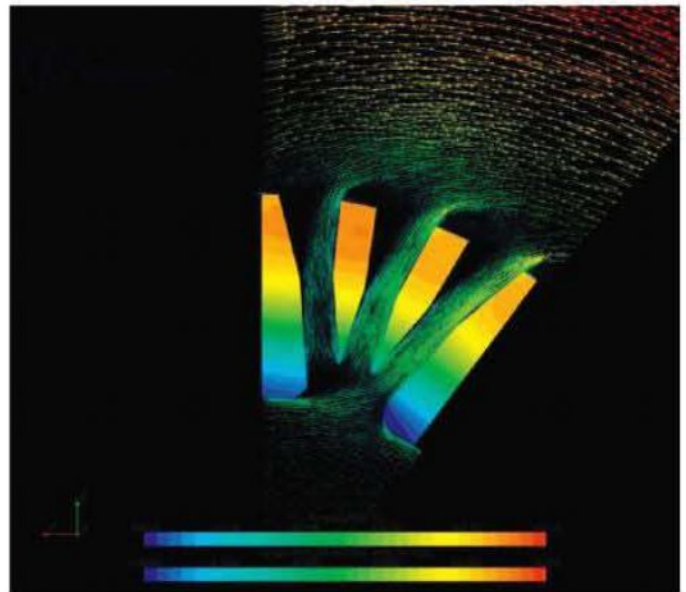

FD analysis of a Brembo Formula One brake disc showing temperature gradients and airflow through the vanes of the rotating disc

vent holes of the chosen shape in the disc. The shape of these vents is effectively unlimited and they can even have different finish textures to increase the turbulence of the air flowing through the disc, to the further benefit of cooling.

Nevertheless, the Hitco material still doesn't cool quite as well as a 3D material. In a 3D material the fibres are 'needled', which pushes some of them through the thickness of the disc. 'Although a 3D material cools better, the user has to get them hot to get the best out of them because the heat tends to soak away from the face,' explains Bryan. 'So unless there is a lot of energy going into the disc, they won't be warm enough. With the

Hitco disc, the heat tends to stay more in the surface of the disc, which means they bite better but they are harder to cool. The others have a bit less tolerance of low temperatures but you can ultimately cool them better.'

Until relatively recently, it was not unusual for a team to switch between carbon-carbon disc and pad manufacturers several times per season, but this practice is far less prevalent today. 'Because the material characteristics are different, the best way of cooling a disc changes from one material to another,' explains Bryan. 'The brake ducting on an F1 car is fairly complicated and is not something the teams would choose to change lightly. There are a lot of moulds needed to make all those

intricate carbon pieces so you can't just change it on a whim. By and large, a team tends to opt for a carbon material and stick to it. However, there are one or two teams where there is a split on carbon material preference between the two drivers.'

#### SWITCH OF ALLEGIANCE

That said, there are still circumstances and considerations that can prompt a switch of allegiance. 'Whenever the regulations limit the cars on grip - such as the introduction of grooved tyres - or cause any significant reduction in downforce, the Hitco material tends to come into favour,' says Bryan, 'because it's happier over a wider range of temperatures

and you can use it if you aren't getting a lot of heat into the brakes. If the cars get more powerful, with more downforce and more grip, then the pendulum swings more towards the Carbone Industrie end of the scale. In 2010, there were a couple of teams that stuck with CI and a couple of teams that stuck with Hitco, but the majority were in the middle and used the Brembo combination.

'It's always interesting to me that there isn't just one material that everybody has identified as the best. It's not necessarily the case that all the really quick cars will be on the same material and all the slower cars on another. You'll find cars right at the front of the grid on all three materials.'

# **Motor** **SPORT** EXPOTECH

**4<sup>th</sup>**  
*edition*

*International Exhibition and conference  
for innovative materials, technologies,  
products and services for motorsport industry*

**Modena - Italy**  
**12<sup>th</sup> - 13<sup>th</sup> October 2011**

- professionalism* ■
- high specialisation* ■
- no frills* ■
- trade visitors only* ■

Organized by:

**ModenaFiere**

**BolognaFiereGROUP**

viale Virgilio, 58/B - 41123 Modena - Italy  
phone +39 059 848380 - fax +39 059 848790  
segreteria@motorsportexpotech.it

**www.motorsportexpotech.it**

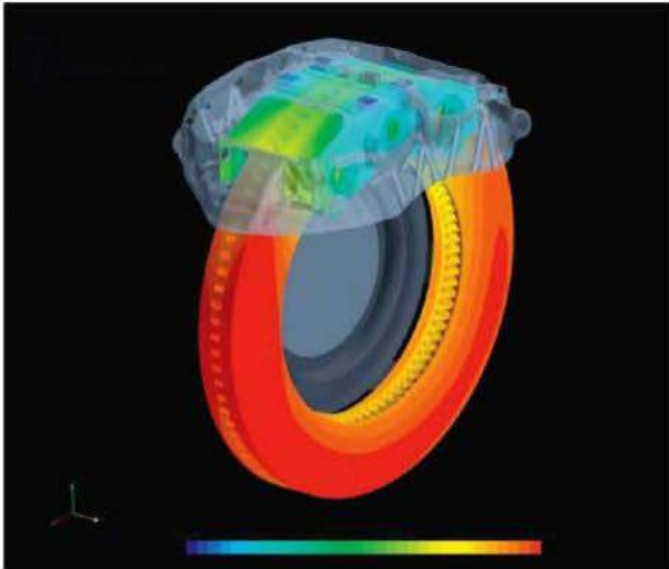

CFD analysis of a complete Brembo Formula One brake assembly

Of course, different materials will find favour with different drivers, depending on their style. Material choice can depend on how experienced your driver is and how much the performance of the car changes during the race. In the turbo F1 era in the mid 1980s, a lot of drivers favoured the CI material because it tended to generate more ultimate friction. The smarter drivers realised that, while that was the stuff to have for a qualifying lap, in the last 10 laps of the race when the tyres were shot and the cars were low on fuel, you were better off with the Hitco material because it was the same on the last lap of the race as it was on the first.'

**PAD DEVELOPMENT**

Compared with previous eras, the current F1 cars have relatively low levels of downforce and this, in combination with their spec tyres, means the cars have relatively low levels of grip. This has, says Bryan, resulted in little evolution in the size of brake pads. 'If you have a situation where you've got lots of grip - either through the size of the tyres, the downforce available or the horsepower, that means you can add downforce - and you get to the point where car development goes down the route of high grip, then the brakes will be punished. Under certain circumstances it's possible to get to a point where, if the driver is

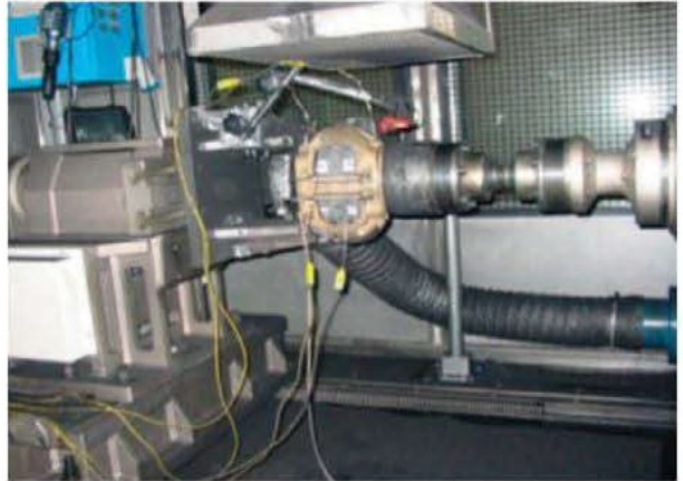

A Formula One brake disc is tested on Brembo dynamometer

able to brake late enough because sufficient grip is available, you can get enormously high temperatures at the interface of the pad and disc. There's no time for the mass of the disc and pad to have much effect and you can actually fade carbon-carbon. You can saturate it with so much thermal load to the point where the friction starts to tail off. So in the past we have made calipers with even larger pads for those situations. The aim is always to try to keep the carbon within the surface temperature range where you've got decent friction. A longer pad gives you more surface area to dissipate the energy, so therefore the temperature will be lower.

Carbon-carbon brake pad materials are subtly different to the disc materials. One major

requirement for disc material is that it has to have adequate strength so that it does not break when it's worn. 'The pad needs less tensile strength so you have a bit more freedom,' explains Bryan. 'Some of the post-processing treatments that are used will weaken the carbon, but you can probably do more of that, safely, to a pad material than you can to a disc material. That gives you more freedom to adjust thermal conductivity and the other elements that give friction in a pad.'

'Because of the different volumes of carbon in each, a disc is easier to cool than a pad, but some pads give more problems than others. If you have a pad with low thermal conductivity, the heat doesn't transfer through to

**BRAKE DYNAMICS**

➔ The Formula 1 technical regulations state, 'Any powered device which is capable of altering the configuration or affecting the performance of any part of the brake system is forbidden.' This means the brake system cannot incorporate any electronics, aside from pressure sensors and travel transducers on the master cylinders. No kind of power assistance can be connected in any way and all the energy in the braking system has to be generated by the driver.

**POWER-ASSISTED BRAKES**

In the past, F1 cars have had power-assisted brakes - for example in the active suspension era in the early 1990s. In those

times, the cars had large capacity hydraulic systems that operated the suspension and gearshift, but there was also enough spare capacity to provide a power-assist system for the brakes. 'In the active suspension era, the cars had so much downforce that it wasn't possible for the driver to press the brake pedal hard enough to stop the car as quickly as it potentially could be,' says Bryan. 'Once the grooved tyres and lower downforce regulations came in, it was again possible for the driver to easily generate enough load to lock the brakes.'

When electronic driver aids were outlawed, computer controlled dynamic brake balance (DBB) adjustment was one of

the casualties (although driver-operated manual brake balance adjustment remained).

When a DBB system-equipped car braked, bias was shifted to the rear to pin down the back end of the car then, as speed was scrubbed off and grip levels reduced, the bias would migrate to the front so as not to lock up the rear wheels. In some systems, as the car was approaching the corner, downforce was reducing and the driver was easing the brake pressure, the bias would - at the last moment - migrate back to the rear end of the car again to unload the front tyres so that it was easier for the driver to turn in and add lateral load. 'That way the front tyres were not swamped

with longitudinal load and the car was less likely to understeer,' explains Bryan. 'The DBB system would drive the brake balance backwards and forwards during the 1-1.5 seconds that the driver was on the brakes.'

Despite the electronic driver aids ban, not all of the benefits of dynamic brake balance shifting were lost. What changed was the way in which they were achieved. 'Over the last few years, as the tyre and aero regulations have changed in F1, the attractiveness of being able to shift the brake balance has grown again,' says Bryan. 'When the cars had grooved front tyres the contact patch was, initially, quite small so it was not unusual to end up with a situation



Many Formula One teams use a spline mounting for brake discs which offers reduced weight and mechanical advantage

the back of it to the pistons and caliper. That makes life easier for the brake system as a whole, but obviously there will be occasions when you don't want to run that type of pad and use a higher conductivity one instead. Then you will see a step change in caliper temperature.

'There isn't a hard and fast rule because some pads wear out quite badly but, by and large, discs tend to wear more than pads. Some of that wear is driven by oxidation and that can obviously only happen in the presence of

oxygen. Because the face of the pad is pushed up against the face of the disc it's harder to get airflow under the surface of the pad than over the surface of the disc, so the disc tends to wear more. At the end of a race it's not unusual to find discs that have holes worn through into the vents while the pads will still be 16-18mm thick.'

**RULES OF ATTACHMENT**

Among the Formula 1 teams there are currently two differing schools of thought on the attachment of

the brake discs to the hubs - the traditional method using a ring of 10 bolts or a spline drive arrangement. 'With the traditional method there's a sleeve that goes through the attachment hole in the disc itself as you can't just tighten a bolt against the material or you would crush it. Into the sleeve goes a quarter-inch bolt with a washer on the back, and on the front there's the squared-off bobbin and the nuts.

'We used to have to 'float' cast iron discs because they expand and contract quite a lot. If you restricted that movement it would add to the stresses and they were more likely to crack. You tend not to need to do that with carbon-carbon. There will be a little bit of float, but the main reason for that is to make a break in the thermal path from the disc to the mounting bell. The amount of float is really just enough to allow the disc to rattle, but it's barely perceptible. All you want is enough gap so there isn't clamped contact and there's no direct heat path.

'Recently, some of the teams have come to view the traditional disc mounting method as a bit heavy. You can combat this by using titanium bobbins, but the

bolts and the other hardware are steel and there's quite a lot of it. On an F1 car, a 30mm long, quarter-inch bolt is quite a large piece of metal, and having 40 of them depresses the engineers.

'As a result, some of the teams have switched to a system where splines are machined around the inner circumference of the discs, which mate with corresponding splines on the mounting bell. The two are then held together by four or five small bolts and keepers. Although this is a bit of extra complication in manufacturing, there is quite a significant weight saving and also a potential mechanical advantage. With the traditional method the discs are offset to the side so there is a twisting moment on the mounting bolts every time torque is applied - up to 3000Nm each time the driver hits the pedal. With the spline drive arrangement the torque is applied down the centreline of the disc.'

More advances in brake system engineering will undoubtedly come to light in the future but, for the time being, the carbon - carbon set ups seen on Formula 1 cars are the state of the art in high-performance motorsport braking technology. 

**BRAKE DYNAMICS - continued**

where, towards the end of a stop, the driver would want to turn in to the corner and either the front inside wheel would lock as soon as it was unloaded or the car would just understeer because all of the tyre capacity was being used up by the longitudinal deceleration. The addition of a lateral force was more than the tyres could deal with. So the teams were looking for ways to shift the balance to the rear again during braking but they couldn't use an automated system.'

**PROPORTIONING VALVES**

The solution came in the somewhat prosaic form of AP Racing's brake proportioning valve, that had originally been designed more than 20 years earlier for use by club rally competitors. 'If you run a Group N car with an essentially standard

brake system and aren't allowed to fit a pedal box and twin master cylinders, yet want the facility to alter the brake balance, you can use one of our proportioning valves,' explains Bryan. 'It's plumbed into the rear brake line and allows the driver to reduce the effectiveness of the rear brakes, giving a degree of balance between the front and rear.'

In fact, the Formula 1 teams weren't using the valves just because they were a means of adjusting brake balance, but more because of a particular characteristic of their operation. 'There is a certain amount of hysteresis in the way the valve works,' explains Bryan. 'Once the driver has put pressure into the rear brake line, as he would with a single-seater car with downforce, the brake pressure profile is a sharp climb to a very high level

and then an easing off. Then, as the grip level drops away, the driver backs off the brake. Once fluid pressure has been pushed through the proportioning valve to the rear calipers, when the driver goes into reverse and starts to reduce that pressure there is a lag as the pressure is held downstream until the valve finally opens. The net effect of that lag is that as the driver eases off the brakes, front braking is reduced but rear brake pressure remains as it was for a short period. This effectively gives the driver what he wants in terms of a rearward shift in brake balance.

'It's amusing to see a number of multi-million pound racecars using a £90 proportioning valve normally found on a club rally car!'

With regard to the 2011 season and its demands on brake technology, Bryan observes,

'In 2010, the cars were using quite large slicks at the front and, if anything, the teams were struggling to get them to work. They could cope with anything you could throw at them. It will be interesting to see what happens if the 2011 Pirelli tyres are a bit fragile, or are going to be so for large periods of a race, then there might be a resurgence of interest in the proportioning valve.

'Also, the re-introduction of KERS will have an influence because, theoretically, it takes a little bit of the braking energy and stores it away. So, if you assume that you are going to have less wear at the rear of the car, you can make the pistons and cylinder smaller and the caliper narrower, which will save weight and, of course, the teams will jump at anything that saves weight at the rear of a KERS car.'



## a new generation connecting rod

M2000 is a truly exciting & innovative advance in material specification, bridging the gap in cost and performance.

- reduced component mass
- exceptional core strength (2100MPa)
- increased durability
- maintains plastic elongation
- low notch sensitivity
- ideal for high stress applications
- high fatigue strength
- high tempering steel



**Arrow Precision Engineering Ltd,**  
12 Barleyfield,  
Hinckley Fields Industrial Estate,  
Hinckley, Leicestershire.  
LE10 1YE  
United Kingdom

**tel:** +44 (0)1455 234200  
**fax:** +44 (0)1455 233545  
**web:** [www.arrowprecision.com](http://www.arrowprecision.com)  
**email:** [enquiries@arrowprecision.com](mailto:enquiries@arrowprecision.com)



Made in England



authorised Agents for ARP

at the heart  
of the world's  
most powerful  
engines.

# D.A.T.A.S. LTD.

Data Analysis Tools And Simulation

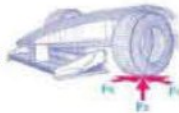

## RaceSim version 2.7

- **Expert:** Steady state, transient, 4 post, optimisation, strategy, etc
- **Standard:** Low cost lap simulation
- **NasCar:** Stock cars with live axle
- **F3 Lite:** Incl. Dallara F3 car model
- **RaceAlyzer:** Race strategy tool - **NEW**
- **ManagePart:** Parts management tool - **NEW**

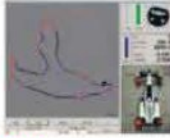

## Consultancy

- Vehicle Dynamics
- Racetrack support
- Software Development

## Multi Media

- Photo realistic virtual animations
- Technical Features for TV
- Animated virtual walk thro' grid



See D.A.T.A.S. at the Autosport Engineering show

D.A.T.A.S. LTD. THE OLD CHAPEL NORFOLK IP21 4XP

TEL: +44 (0)1603 506526 +44 (0)7802 770345

<http://www.datas-ltd.com> e-mail: [info@datas-ltd.com](mailto:info@datas-ltd.com)

ECU/Exchange Loom/Throttle Body Packages available

# Complex modern engine? We can manage it

ECU solutions for:  
Honda S2000 and K20A  
Ford ST170 and Duratec  
Toyota 2ZZ  
BMW Single / Twin VANOS  
Audi 1.8T and 5 cylinder  
Chevrolet LS7.

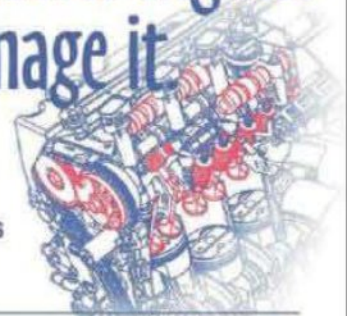

Our ECU's are capable of dealing with the most complex of modern engines without the need to change sensors or sacrifice key features such as variable camshafts.



Get the very best from  
any engine and from only **£495.00 + VAT.**

DTAfast, 10 Boston Court, Kansas Ave, Salford M50 2GN  
Tel: +44 (0)161 877 1419 Fax: +44 (0)161 877 7086  
Email: [office@dtafast.co.uk](mailto:office@dtafast.co.uk) Website: [www.dtafast.co.uk](http://www.dtafast.co.uk)

# Top Qualifier

Around the world or around the track, you won't find a higher quality line of bearings and rod ends with Aurora's proven 35 year track record.



Aurora Bearing Company  
901 Aucutt Road  
Montgomery IL. 60538



Complete library of cad drawings and 3D models available at:  
[www.aurorabearing.com](http://www.aurorabearing.com) Ph: 630-859-2030

# Snapdragon ENGINEERING, LLC

DESIGN \* FABRICATION \* RACING SERVICES

Clients in Formula categories, LMP and Rally find consistent value in our component manufacturing services for prototypes and short-run production. We seamlessly combine CNC precision with traditional fabrication techniques to produce high value, high performance parts.



Championship winning Ohlins racing dampers custom built for any application supported by a full testing and service facility, complimented by Hypercoil chassis springs and hydraulic perches.

Exclusive North American agent for Farrington Instruments. Contact us for details about their range of superb race car data acquisition equipment and analytical tools.

FARRINGTON



OHLINS  
ADVANCED SUSPENSION TECHNOLOGY



HYPERCOILS  
Precision Suspension Coils



00 1 413 256 0861 Amherst, Massachusetts, USA [www.snapdragonms.com](http://www.snapdragonms.com)



# Doing it yourself

There's no substitute for doing your own simulation, and no excuse for not simulating...

**R**acecar simulation has emerged as an important part of the motorsport engineering framework and, as the principal of ChassisSim, I have seen first hand how it has changed the sport. I have lost count of the number of times ChassisSim has dictated what's happening during a session for a number of my customers. And once you get your head around what racecar simulation is, and what it is truly capable of, it will become an indispensable tool for all of you.

BY DANNY NOWLAN

The purpose of this article is to tell you why, by demonstrating first hand what it can do and what it has done in the field.

Let me apologise in advance to any readers who were looking forward to one of my articles where I outline the nuances of vehicle dynamics and fry their brains with truck loads of equations. This is not going to be one of these articles.

Over the last year, one of the most alarming trends I have seen in our industry has been its

dumbing down, and I intend to fight that with all the tools I have available. I also don't care who I annoy in the process. I have seen this happening with governing bodies imposing ever-crazier technical restrictions and even crazier gimmicks to improve the show, and I have seen a growing ambivalence in some in our industry to anything that smacks of serious engineering. The thin edge of the wedge has been fixed sim packages for senior formulae and a definite lack of serious engineering analysis of the racecar. Make no mistake, if we go



down this route we will be slitting our own throats and dooming ourselves into irrelevancy.

On a personal level, I think you have to be certifiably crazy not to use racecar simulation in preparing for a race event. I don't just say this because I have a financial interest in people doing so, it's just plain common sense. Think about it even on a club level - preparing a racecar takes significant time and energy and, when you get to the track, you expend time and expense being there. Given this, it would be inadvisable for you to not take all the necessary steps to ensure you got the most out of that valuable time on track.

**COMMON COP OUTS**

Yet racecar simulation is often the most overlooked tool that race teams have at their disposal. The two biggest objections I see to people adopting racecar simulation, or at least having it as a priority, are as follows:

- We'll just use data and test like we've always done
- We're so busy setting up we'll worry about simulation later

My answer is that both of these are cop outs. While data acquisition and testing are necessary tools, they are reflective ones at best. Yes, you still need to do them but, strictly speaking, they will only tell you what has happened in the past. However, when this is combined with simulation software the results are stunning. As for the second objection, my answer is that setting up a simulation model is an indispensable step in understanding your car. I personally think it's madness trying to derive a set up without understanding your aero or tyres and these are the two big things simulation software can help determine. The two reasons racecar simulation is so important:

- Developing a vehicle model forces you to understand your racecar. This is an invaluable addition to your car's database
- When you do step 1 properly, simulation will narrow down what you need to test on the track.

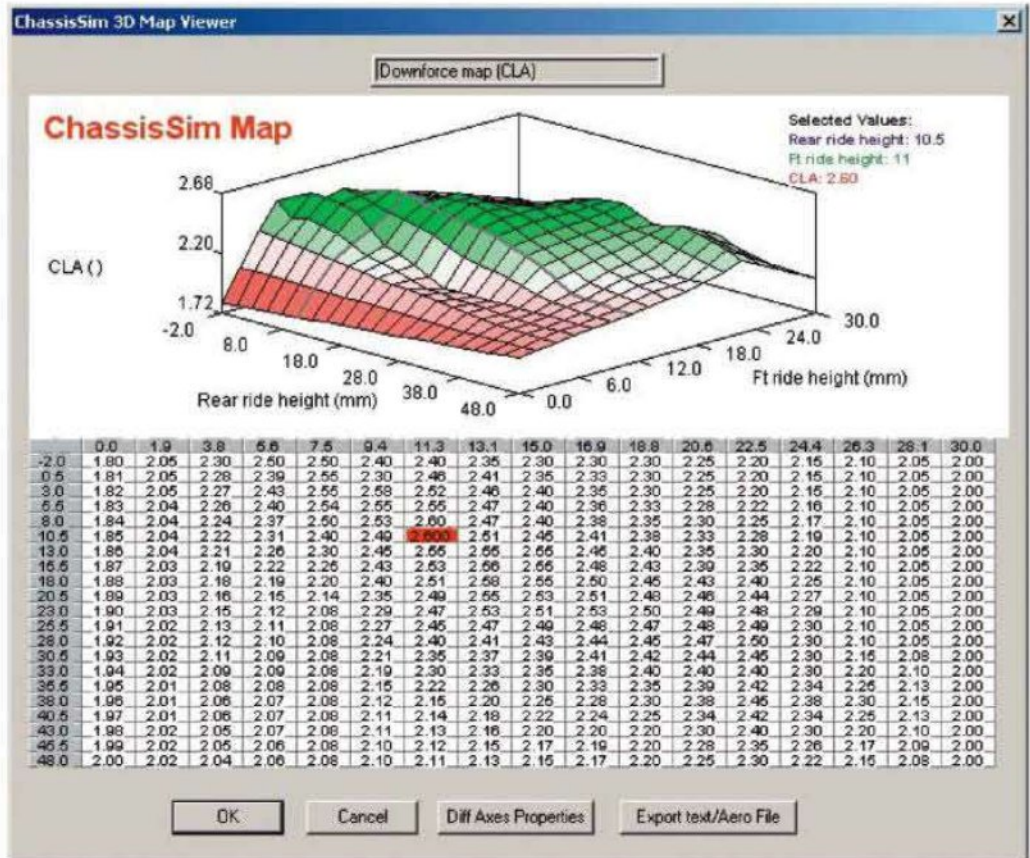

Figure 1: A1GP ride height sensitivity map

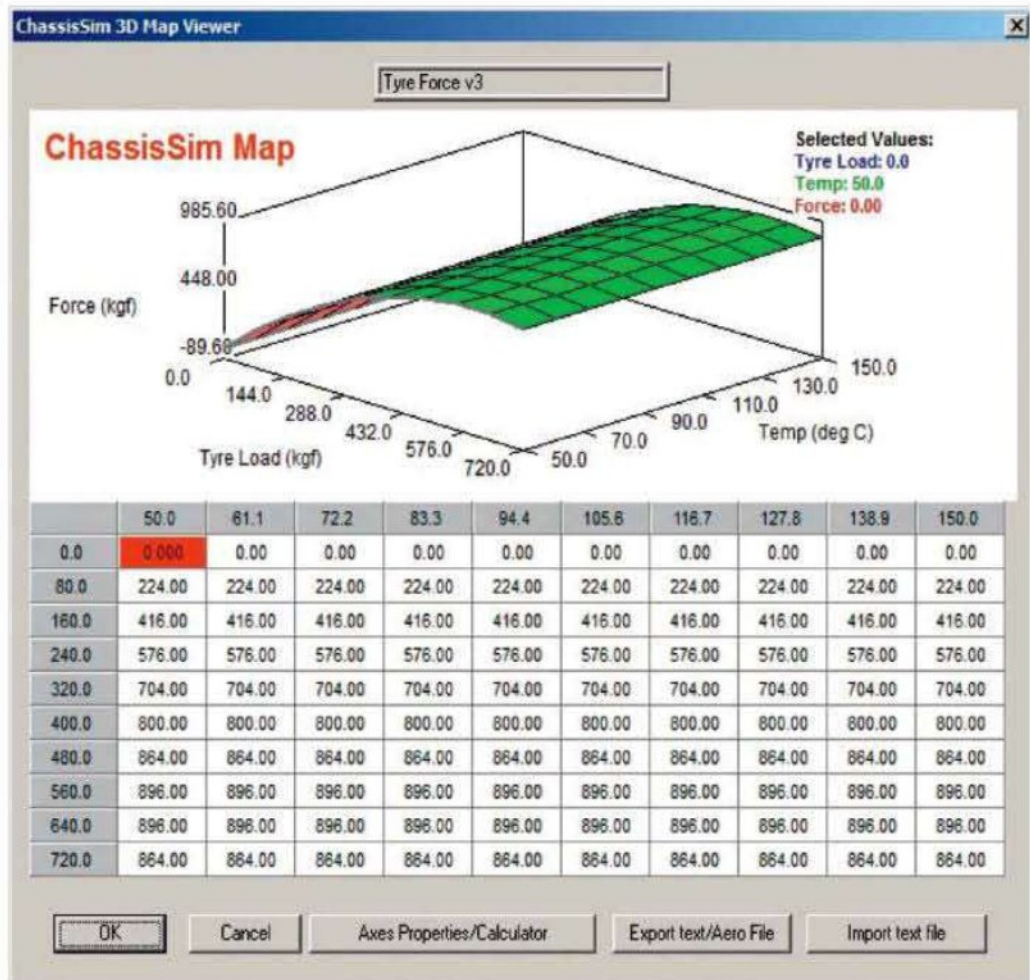

Figure 2: plot of traction circle radius vs load for a race tyre

$$\alpha_f - \alpha_r = \delta_{steer} - \delta_{N.S}$$

(1)

$$\Delta\delta = |\delta_{steer} - \delta_{N.S}|$$

For U/S,

$$m_t \cdot a_y = f \kappa(\alpha_f)(F_{y1} + F_{y2}) + f \kappa(\alpha_r - \Delta\delta)(F_{y3} + F_{y4})$$

For neutral steer

$$m_t \cdot a_y = f \kappa(\alpha_f)(F_{y1} + F_{y2}) + f \kappa(\alpha_r)(F_{y3} + F_{y4})$$

(2) For oversteer

$$m_t \cdot a_y = f \kappa(\alpha_f - \Delta\delta)(F_{y1} + F_{y2}) + f \kappa(\alpha_r)(F_{y3} + F_{y4})$$

Our goal here is to build up a picture of lateral force vs load. Effectively our goal is to populate this function

(3) 
$$F_{yi} = f \kappa(L_i)$$

Where  $F_{yi}$  is the relevant lateral tyre load and  $L_i$  is the tyre load. By comparing the mid-corner data using equations (1) - (2) you can start to populate equation (3)

If you have strain gauges fitted to the car you can simply read it off the data at the appropriate mid-corner points. If you don't have strain gauges, this is where the simulated data comes to the rescue. All you need to do is start off with a basic tyre model, adjust the grip factor, note the tyre loads, and you will start to build a data base for equation (3)

Racecar simulation fits into the motorsport engineering landscape as the next step on from data logging. Data logging will tell you what happened but, combine that with simulation, and it will also tell you why. This is the critical edge that wins races.

To get the most of your simulation you must do the modelling yourself. This will force you to understand your car in ways you never thought possible. It will also tell you what to look for in the simulated and actual data. Also be very careful of so-called complimentary simulators provided to you by racecar manufacturers, particularly when the models in these sim packages are locked and they don't supply the information about how they derived the model. Over the last

five years I have lost count of the number of racecars, in particular spec cars, I've had to model. A lot of them came with manuals and aeromaps but, in general, these cars have been very difficult to model for the following reasons:

- **There have been significant holes in the manuals provided. In one case, the bar rates were off by a factor of 2!**
- **The aeromap that was provided had no connection with reality. It might give you a rough idea of what to expect in terms of downforce and drag, but the pitch sensitivities were highly inaccurate.**

In many cases the complimentary sim packages

are done to a budget rather than a standard. They're also an extension of the fact that you can't take anything for granted in this business. There is simply no substitute for doing the modelling yourself.

To illustrate how powerful racecar simulation can be when it is done properly, let's consider a couple of case studies.

The first concerns the first generation A1GP car. On paper, this car should have been the easiest thing in the world to set up. After all, it was based on a chassis / engine platform that was over 12-years old. There was just one little problem - due to

car worked. Using the ChassisSim aero toolbox we were not only able to define it, but quantify it, too. Consequently, we could then use simulation to dictate at what ride heights the car should be run at, which was critical to getting the car to work. It also illustrates to me just how important it is to do the appropriate ride height sweeps so you can reverse engineer your aeromap. Team managers may look at you oddly, drivers may complain how boring it is, but it is critical because once you have this data the aero testing you need to do from that point is negligible because you have covered yourself for so

## There is simply no substitute for doing the modelling yourself

requests by the series creators, the A1GP car finished up with the following characteristics:

- **Some unique aerodynamic appendages gave the car a rather unique aesthetic**
- **Tyres were unlike anything seen on a modern high downforce open wheel**

Consequently, all the chassis set up experience previously built up with this platform was completely useless. The first challenge with this car was to construct an aeromap. Unfortunately, due to time constraints, the aeromap supplied by the manufacturer didn't provide the complete picture. This is where the ChassisSim aero toolbox proved to be invaluable. This was a brilliant case study of why it is so important to review your data scientifically. Fortunately, the engineer I was working with on this had tried so many different set ups that we had just enough information to construct the aeromap. This is shown in figure 1.

This map was absolute gold because it showed there was a definable sweet spot in the aeromap. One of the idiosyncrasies of this car was that there was a very fine ride height range in which the aero of this

many different scenarios. Also, for medium downforce cars and above, it is a crucial aspect of car performance that can be the difference between winning and losing. This was a case in point...

### TYRE CHARACTERISTICS

The next point I'd like to discuss is how valuable simulation software is for reverse engineering your tyre characteristics. One of the biggest objections I hear about people not using simulation software is we don't have a tyre model. Well, guess what? You can use your simulator and a couple of well informed guesses and data comparisons to fill in the blanks. There are just a few tricks you need to do be aware of.

The first is to look at your mid-corner data properly. The trick is to compare actual steer to neutral steer, and from that you can determine the appropriate details. I outlined this in detail in one of my earlier articles, but the highlights are in the equation box above left.

Some racecar simulation packages come with tyre force modelling features that will do this for you automatically. The ChassisSim tyre force modelling and tyre force estimation toolboxes are cases in point. When you are done, you are going to wind up with something

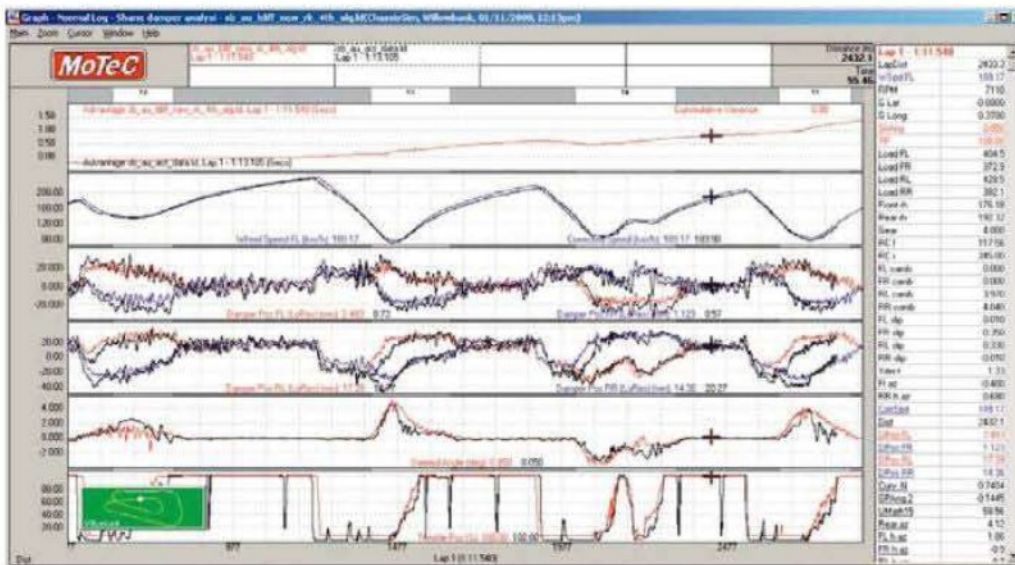

Figure 3: correlation from a V8 Supercar

that looks like figure 2, which is a plot of traction circle radius vs tyre load.

The results of figure 2 are pure gold, because this is the tyre equivalent of an engine dyno. This is critical for racecar set up because now you can quantify what a set up change is going to do to the racecar. Also, if the results on track don't match up, it will tell one of two things:

- Either there is a non-linearity in the tyres you need to consider
- Or your driver needs instruction...

Using these techniques and

the ChassisSim toolboxes I have personally constructed a plethora of tyre models without having seen any tyre test rig data. These have been in categories as diverse as F3, A1GP, V8 Supercars and Star Mazda. This illustrates why racecar simulation is so powerful because it enables you to extend your data use in areas that you may previously have thought were impossible.

When you have done your aero and tyre modelling, measured the car correctly and I guarantee you the correlation will take care of itself. You should expect a correlation that looks something like that shown in figure 3, above.

The simulated data is black

the actual data is coloured.

This correlation in particular really highlights the power of simulation when used properly with the minimum of fudge factors. In this particular correlation, you can see where the driver is doing well (mid-corner in the low-speed turns) and where the driver is struggling (braking and turn in and exit from the corner). Furthermore, the three things that give you confidence are the match up of the mid-corner speeds, the steering correlation on the way into and out of the corner and the initial throttle application. At an instant you can see what is going on with the car and whether

the set up and / or driver need tweaking. This knowledge is invaluable to an engineer.

When racecar simulation is set up properly, you can effectively rock up to the race track with a turn-key set up. Let me illustrate with an actual example. One of my customers was an LMPC team in the ALMS category. They had no budget for testing, so effectively ChassisSim was the test program, shaker rig and aero analysis tool all in one. At one particular event they were one of the few teams who were not present at pre-event testing but that didn't stop them being on pole by a margin of nearly one second! This is what can be achieved through the intelligent and diligent use of racecar simulation software.

In closing then, if you are serious about winning, racecar simulation software is a must-have tool. Using it properly you can reverse engineer vehicle parameters such as the aero map and the tyres, both of which are vital in understanding your racecar and getting the most out of it.

Also, once the model is set up correctly, the correlation will come as a by product and will tell you what to do well before you get to the race track. In a business that can be decided by tenths of a second, racecar simulation well tell you where to find these gains.



Next month in

The International Journal of Motorsport Technology

# Racecar engineering™

- LE MANS Peugeot 908

Plus:

Advanced wing concepts, Audi R18 TDI, simulation technology, Lotus-Caterham

On sale June 10

## Don't Run the Risk of Contaminating your Engine!!!

Our service is renowned for its quality, speed and level of cleanliness that is paramount when supplying the highest levels of performance. We at Serck Services Motorsport are dedicated to providing our Service Cleanse Packages to all High Performance Areas in Motorsport all over the world.

Photo analysis service cleansing down to 50 Microns for all types of Cooling Systems.

Water  
Engine  
Transmission  
Hydraulic  
KERS  
Fuel Lines  
Hydraulic Lines



Service also Includes:

Flow Testing, High Pressure Testing, Fin Repair and Analysis Data.

Full Data package provided with each unit serviced.

Performance History also recorded for Data Comparisons.

Supplied to Formula One Teams World Wide for over 10 years.

Serck Services Motorsport  
Units 9-11 Bullsbrook Road, Brook Industrial Estate,  
Hayes, Middlesex, UB40JZ, England  
Telephone: 0208 813 7470/0208 5611508  
Mobile: 07831 327654



[www.serckservicesmotorsport.co.uk](http://www.serckservicesmotorsport.co.uk)

# AERODINE

COMPOSITES GROUP



ADVANCED COMPOSITE TECHNOLOGIES  
FAA CERTIFIED REPAIR STATION RDMR624X

- STRUCTURAL COMPOSITE ENGINEERING
- PRODUCT & TOOLING DESIGN
- CAD/CAM
- FINITE ELEMENT ANALYSIS
- PROTOTYPING
- MANUFACTURING
- STRUCTURAL REPAIR

*Serving the Motorsports Industry Since 1989*

[www.AerodineComposites.com](http://www.AerodineComposites.com)

Tel. +1 001.317.271.1207 • Fax. +1 001.317.271.4455

8201 Indy Lane, Indianapolis, IN 46214



## Quality cable looms from a military supplier



Looms manufactured using Raychem System 25 methods from our 10,000sqft facility in Southampton.

We are tooled for most connector manufacturers and everything is 100% tested using Cirris CH2 hardware.

We are ISO9001, 14001 and OHSAS18001 approved.

Contact us now to help with designs, or to quote against current requirements.

UNIT 14 MOUNT PLEASANT INDUSTRIAL PARK,  
SOUTHAMPTON, SO14 0SP, ENGLAND

TEL: +44 23 8022 7636

[www.motorsportcables.com](http://www.motorsportcables.com)

EMAIL: [sales@st-cross-electronics.co.uk](mailto:sales@st-cross-electronics.co.uk)

St. Cross Electronics



# Capricorn Automotive moves into supercar sector

Precision engine component manufacturer uses its capabilities to expand its business

**Martin Keswick**, managing director of Capricorn Automotive, chooses his words carefully. 'Motorsport, and Formula 1 in particular, is still a very important part of our business, I wouldn't want anyone to think otherwise. But, let's face it, regulation changes, such as those in Formula 1, have reduced the number of engines used and the number of parts we can supply.'

Keswick's frankness about future growth opportunities in motorsport is particularly interesting considering the company's track record in supplying professional racing teams. From its 40,000sq. ft facility in Basingstoke, UK, which houses 55 employees, the company supplies precision machined engine components, including forged pistons and cylinder liners, to most major forms of motorsport, from Formula 1 through to NASCAR, Le Mans, World Touring Cars and the WRC, amongst many others.

'Motorsport is still our core but, due to reducing volumes, it is in effect a declining market,' he says. 'Regulations are meaning less variety and fewer components. Take IRL (Indy

Racing League), for example, which in 2012 is changing engine configuration from V8 to V6 – that's a 25 per cent reduction in [component] volume right there.'

And, as volumes drop, so competition increases. 'The volume drop has increased price competition and reduced margins as companies try to keep their machines busy,' continues Keswick. '[but] there are still some very attractive segments in motorsport, such as NASCAR where engine component volumes remain strong.'

**due to reducing volumes, it is in effect a declining market**

Keswick believes Capricorn Group, which also has facilities in France, Germany and Italy, has been fortunate in being owned by a far-sighted shareholder who is willing to plan for the long term. 'We are owned by a single German shareholder, Robertino Wild, who has a passion for engines, machine tools and motorsports. That security has enabled us to make a strategic

decision to target niche automotive sectors that the big players tend not to be interested in. Our growth is now coming from other segments, such as high-performance road cars, or 'supercars' as we call them.

'The difference between the supercar sector and motorsport lies as much with batch sizes as the type of component machined,' says Keswick. 'Tolerances on road cars and professional race series vehicles are not much different nowadays. However, F1 may only want 600 pieces a year,

commit, they want it immediately. Of course that demands a higher price and a better margin.'

## SPECIALIST PROCESSES

Capricorn's Basingstoke premises is equipped with a variety of specialist processes such as piston forging, electro plating and honing. However, the main activity is in the machining centres and turning equipment for both rough and finish turning. 'We don't necessarily need super precision if the application does not demand it,' explains Keswick. 'We are working on cylinder liners to a typical 10micron cylindricity tolerance, so what we are looking for is good metal removal rates, combined with good dimensional and geometric control.'

The company's latest investment is two Mazak Quick Turn Nexus 200 MSY machines. 'We were about to place an order for one new lathe with a competitor but decided to take a look at the Mazak product at one of their open house events. The perception we had was that Mazak was mainly into mill turn Integrex-type machines and not a company we considered for a standard lathe package. However,

whereas our road car customers want anywhere between 5000 and 30,000.

'The road car business is very much the bread and butter of our company now. It's stable business, not great margin but a consistent contributor, whereas motorsport is very volatile, very seasonal and very demanding. We have customers ordering later and later but, when they finally



## Award for enterprise

**UK-based Interex Motorsport** has announced that it has been awarded the Queen's Award for Enterprise: International Trade. International Export Supplies trades as 'Interex' and 'Interex Motorsport' and started life in a converted chicken shed in Berkshire in 1997, with the business relocating to Suffolk in 2000. Whilst Interex specialises in exporting parts for cars, trucks, buses and public service vehicles, Interex Motorsport has established itself as one of the UK's leading exporters of specialised motorsport components

and equipment. Working closely with the UK's world-leading motorsport manufacturers, Interex Motorsport supplies race and rally teams, constructors and specialist tuning shops across the world. Managing director, David Dodd, said, 'We are thrilled to receive the Queen's Award for International Trade. It is the most coveted UK business award and is testament to the hard work of the dedicated staff at Interex. Having a close working relationship with customers and manufacturers is critical to our success.'



The comprehensive machine shop at Capricorn Automotive in Basingstoke, Hampshire, UK

looking at the specifications and stated accuracies we were very surprised at how price competitive they were.'

'Some of our key setters and team leaders were sceptical about using the Mazatrol conversational programming. We sent these guys up to Worcester to use the Mazatrol system and they came back and said "we have to go with Mazak". They all found it more intuitive and easier than the old long-hand programming route, and now they view Mazatrol as a positive rather than a negative. Overall, the new machines are giving us much quicker changeovers and much greater flexibility.'

These new machines are being targeted specifically at Capricorn's motorsport work, which has allowed Keswick to create two distinct areas of capability. 'We have a specific motorsport section, which is where the Mazak machines are housed, alongside a volume supercar section, which houses the machines the Mazaks have replaced.'

The package that Mazak offered to Capricorn resulted in not one order, but two: 'Originally, we were only going to buy one new machine, but Mazak offered us good options across multiple factors, including price, package and performance, which meant we could afford to invest in two machines.'

Keswick also believes Capricorn's new premises are another excellent selling tool. 'We are able to bring high-level clients here, which is important when you are dealing with buyers in the high performance road car market. The first impact of the new building is very strong. We look professional.'

Overall, Keswick is confident that his niche strategy will continue to pay dividends. 'We've got the strategy, the people and the machines to continue to be successful. Motorsport is still our core business but we have been able to take our experience and capabilities into a complementary sector, which has given us a better balanced business.'



## UK invests in technology

The UK government has announced that over 150 British companies, further education institutions and other organisations are set to share around £18 million of government investment to support innovation and growth in a number of important technology areas. The investments follow the conclusion of a major competition for collaborative research and development

funding, managed by the government-backed Technology Strategy Board, with funding awarded to 43 major research and development projects.

The funding awards are intended to be used by innovative businesses and their partners, with the intention of keeping the UK at the forefront of modern technology development. The funding has been awarded across a range of technology

areas, including advanced materials, biosciences, electronics, photonics and electrical systems, high-value manufacturing, information and communication technology and nanotechnology.

Particular emphasis has been placed on the development of 'enabling technologies', which can lead to the creation of other products or processes able to support future development.

## BRIEFLY...

### Three more years

The UK arm of Pirelli tyres, Pirelli Tyre UK, marked its third season as the control tyre supplier to the British GT Cup by extending its agreement with the series organisers for a further three years. The new agreement, which runs until the end of the 2014 season, will also cover the GT Trophy Endurance Series, a non-championship competition offering racers more mileage behind the wheel of their high performance sports cars at selected venues around the United Kingdom.

### Complete suite

VI-grade GmbH, provider of products and services that bridge the gap between technical simulation and real world testing, has announced that BIT-Racing, the Formula SAE team set up by undergraduate students in Beijing Institute of Technology, has selected VI-MotorSport to optimise the set up of its racecars.

### Lotus Renault go PLM

Lotus Renault GP has announced a new agreement with Proccesia Solutions, one of the team's technical partners since 2005. Proccesia Solutions, with offices in France, UK and Canada, specialises in the implementation of Product Lifecycle Management (PLM) solutions and provides advanced software development services. Lotus Renault GP hope the agreement will help enhance integration and efficiency within the design, manufacture and race engineering departments of the team.

### Commitment from Dell

Team Lotus has announced that computer manufacturer, Dell, has upgraded its commitment to become a technology partner. Dell branding made its debut on the T128 at the 2011 UBS Chinese Grand Prix in Shanghai. The investment gives Team

*continued...*

## STRAIGHT TALK

# Brakes off, Bernie - F1 needs to change



PAUL J WEIGHELL

I'm anti, anti, anti, moving into this small turbo four formula. I don't see the need for it,' opines Bernie Ecclestone. But Jean Todt of the FIA knows that engine sponsors do see the need for it. The question is, who will win out in the end?

Any business has two sides - consumers and suppliers. Ecclestone is right that racing consumers like big noisy engines, but he ignores the increasing difficulties facing suppliers. EU legislation now forces manufacturers to limit the CO<sub>2</sub> their road car engines create and, by 2012, at least 65 per cent of new cars registered in Europe per manufacturer must average below 130g/km. That rises to include 100 per cent of their new cars by 2015, and by 2020 the limit itself reduces to 95g/km. Fines up to 95 euros per additional gram of CO<sub>2</sub> per car will be levied on manufacturers who breach the limits.

It is against this background that Ecclestone prefers F1 to retain its current 1200g/km (1.2kg/km) monster CO<sub>2</sub> producers. But what marketing department will want to be associated with dinosaurs in an era of small furry mammals? If he's not careful, Bernie's F1 could become as popular for sponsors as a smoking competition in a maternity ward.

Owing to the daft and now abandoned politics of FOTA, Max Mosley's sensible KERS solution lost two years impact and, to retain legacy, engine formats well into the implementation phase of the EU CO<sub>2</sub> limits will further delay the inevitable and ensure that F1's image continues to repel consumer vehicle manufacturers like flies on butter.

Ferrari, who I am pretty sure have not made a four-

cylinder engine since the 1950s, certainly don't want eco-anything damaging their performance image, hence Montezemolo's slamming of the new engine as 'pathetic' - by which he means of course that it's pathetic marketing for his road cars. If Ferrari is against it, that guarantees it being good for volume manufacturers.

Unlike Ecclestone, Todt has worked for manufacturers for much of his career and fully understands the problems,

**F1 could become as popular for sponsors as a smoking competition in a maternity ward**

hence the new engine spec. A four-cylinder engine enables car makers to downsize their mainstream products with dignity and still retains F1 marketing advantages.

It may come too late to attract the world's largest makers back from Japan, but who will be left holding the baby engine?

Renault remains in F1 only to supply legacy engines until the formula changes, and is unlikely to go beyond that. Their



Perhaps Bernie has forgotten the car he used to win the World Championship in 1983 was powered by a turbocharged four...

road car future policy is 100 per cent electric, eschewing even hybrids, and F1 is anathema to that vision.

Mercedes is without a four-cylinder engine at the heart of their range, but will have to move towards smaller engines to meet the legislation. The company's A and B series sales are likely to be enhanced by F1's four-cylinder marketing and Mercedes will need more of those A / B sales in the mix to lower its average CO<sub>2</sub> figures.

Lotus is, by accident rather than design, in rather a good position. No legacy F1 engine to support and lots of existing development on curious eco-engines, it could not only make a four-cylinder race engine but also use it to enhance its road car sales. Lotus' owner, Proton, may be reaching for its turbos - if it can get the funding to survive at all that is.

Cosworth simply doesn't count in the real world. It has to be paid for its engines, produces no consumer branded goods that F1 can market and makes no net cash contribution into F1. At the limit, Bernie may have to pay Cossie (or perhaps Ferrari or Lotus) to make a spec engine for all the teams and a spec engine series with no major car makers backing teams would be far more damaging for TV figures than competing four cylinder turbo engines made by real car makers.

So swallow the small turbo engine Bernie, and be thankful the EU still turns a blind eye towards Formula 1.

## BRIEFLY...

Lotus access to a new level of technological solutions and provides greater processing power for CFD and FEA.

### A valuable addition

US-based SuperFlow Technologies, a manufacturer of flow testing and dynamometer equipment, has announced that Dynamic Test Systems (DTS) of Shingle Springs, California has been acquired as a division of the company. The company hopes that DTS's range of products will be a valuable addition to SuperFlow's inventory and increase their market share in the sector. 'We are very excited to offer DTS dynamometers alongside our existing SuperFlow dynos,' said Scott Giles, CEO of SuperFlow, adding, 'We have always had a high level of respect for their designs and equipment and are expecting great things moving forwards.'

### No electric shock

Daimler AG and Robert Bosch GmbH have announced plans to expand their long-standing partnership and cooperate in the development and production of electric motors for all-electric vehicles in Europe. The companies have signed a letter of intent and begun negotiations to establish a 50:50 joint venture, which is likely to be concluded in the first half of 2011.

### A double victory

Pro-Shift Technologies Limited has announced that following on from its 2008 IMSA Lites victory, where the company's PS2 paddle shift gear shifting system helped secure the drivers' title, they have now repeated that winning formula with the newly launched PS3. Pro-Shift PS3 customer, John Weisberg, managed to secure a double victory, winning the IMSA Prototype Lites 2010 Drivers' Championship and the Teams' Championship with his Berg Racing team.



Europe's **largest**  
dedicated trade-only  
motorsport exhibition

Thanks to everyone who came along this year

 **AUTOSPORT**  
INTERNATIONAL  
**Engineering Show**

In association with **Racecar**  
The International Market of Motorsport Technology  
engineering

**12 & 13 JANUARY 2012**  
**NEC BIRMINGHAM UK**

**DON'T FORGET TO PUT  
THE DATES IN YOUR DIARY**

**[WWW.AUTOSPORTINTERNATIONAL.COM/TRADE](http://WWW.AUTOSPORTINTERNATIONAL.COM/TRADE)**



**“Our objective -  
to consistently satisfy  
motorsport’s demand  
for the best connection  
system, bar none.”**



• **2008 Champions use BMRS hose:**

NASCAR Sprint Cup, Truck, Nationwide Owners, Grand Am GT, USAC Silver Crown, Hooters USAR, ASCS National and Mid-West, Knoxville & Williams Grove Track, Rally America, European FIA Top Fuel Champion.



• The lightest hose and fitting combination available



• Crimp and reusable hose end options  
• Excellent bend radius - less hose used  
• All one piece ‘billet’ fittings, no brazing



• Four exterior braid options  
• Custom CNC tube bending service  
• Engineering design service - part of your team

*Brown & Miller Racing Solutions*



*Professional Race Hose & Fittings*

[www.bmrs.net](http://www.bmrs.net)

USA: BMRS Concord +1 (704) 793 4319

UK: BMRS Slough +44 (0)1753 545554

**OvaX**  
STEELS FOR THE RACING INDUSTRY

**OvaX 200**

Case hardening steel

**OvaX 300**

Quench and tempering steel

**OvaX 500**

Quench and tempering steel

**OvaX 600**

Through hardening steel

**OvaX 800**

Through hardening steel



**OVAKO**

**Ovako Hofors AB**

SE-712 80 Hällefors,  
Sweden  
Phone: + 46 591 60 138  
Fax: + 46 591 60 606

**Ovako North America, Inc.**

1096 Assembly Drive, Suite 312  
Fort Mill, SC 29708, USA  
Phone: + 1 803 802 1500  
Fax: + 1 803 802 1501

[www.ovako.com](http://www.ovako.com)

**RACEPARTS**

We can supply all the parts...



...You just need to put them all together!

**2011  
Motorsport  
Catalogue  
now  
available**

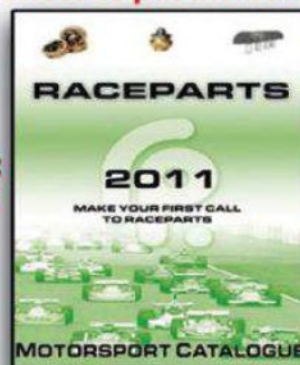

**New Year,  
New Products!**

**Tel: 01491 822000**



[www.raceparts-direct.com](http://www.raceparts-direct.com)



concept & design by racecar publicity management ltd.

## UNDER DISCUSSION: THE F1 SHOW

# The 'show' must go on

Further responses to last month's Late Apex



Last month's Late Apex on the topic of artificial racing stirred up a good deal of response from readers. Graham Jones addresses some of it in this month's column on page 98, but online there has been a good debate raging, so here we have included a further pair of readers' responses.

#### Q: Is the problem track design?

Perhaps a return to drawing out tracks by hand on a piece of paper is necessary, in order to allow for some unintended idiosyncrasies that give the classic tracks the character they now have.

Also, thought needs to be put into passing in multi-corner complexes. Too much focus is currently on the drive-by slipstream pass, whereas simple outbraking and the 'Swedish Shuffle' that Rickard Rydell employed in the BTCC way back are completely ignored.

[At Abu Dhabi in 2010], Why couldn't Alonso get past? Petrov knew he couldn't be outbraked if 1) he stayed on line and 2) he

braked in a straight line for the majority of the braking zone. Why did Kobayashi pass so many cars at Suzuka? Because he was able to brake in a straighter line, and therefore harder than the defending drivers, offsetting the disadvantage of braking off line (there is also the possibility that the supporting races kept the off-line section clean and rubbered in... another factor to think about when planning a grand prix weekend).

The answer seems simple: make the preferred solo line a disadvantage when defending, at least up until the apex, so the attacking driver can have a shot at getting to the apex first and actually make it there. Also, get some Touring Cars and Formula Fords as support races, which will help rubber in the passing zones.

Finally, take off all the gimmicks that belong in Mario Kart rather than Formula 1 (and make KERS a full-time part of the drivetrain rather than a silly push-to-pass gimmick).

**Malcolm Strachan**  
[racecar-engineering.com](http://racecar-engineering.com)

#### Q: Is DRS a gimmick and is KERS a wasted opportunity?

I don't like the fact that DRS is an artificial racing construct (like success ballast). I like my racing pure and the same rules for everyone, although you could argue it's just boosting the performance of the slipstream, much like the old IndyCar Handford wing. While we're at it, let's get rid of the tyre qualifying rules and let everyone choose the tyres they start on.

That said, I was surprised by how much I have enjoyed seeing the flap opening up when it

was allowed everywhere. It was dramatic to watch and it was fun to see which drivers were aggressive with it (Sutil, for example) and which drivers were scared of opening it until after the exit.

KERS, in its current implementation, is just wrong. It should be unlimited in my opinion. There's a natural trade off between weight and boost with the battery weight. Drivers should be allowed to save up more than a single lap's worth and spend it all at once. That would make overtaking far easier too - drivers could save it for five laps, building up a big charge, then use it all in one lap for, er, a big charge. I don't think unlimited KERS would lead to massive costs either - they've already done the hard work and 'unlimited' would just mean more batteries.

So, in summary, I'm not as against DRS as I was, but it needs to be available all around the track. In reality though, I don't think it's really needed if they implement unlimited KERS.

If you have an issue you want to discuss here, please email the editor at: [racecar@chelseamagazines.com](mailto:racecar@chelseamagazines.com) or write to: the editor, *Racecar Engineering*, Suite 19, 15 Lots Road, Chelsea, London SW10 0QJ, UK. Visit [www.racecar-engineering.com](http://www.racecar-engineering.com)

**'Pionir'**  
[racecar-engineering.com](http://racecar-engineering.com)

## Autotel Digital Race Radio

### Motorsports Communications Systems

Complete Range of analogue & digital Race Radio systems for all levels of motorsport.

Show discounts

Dealer Packages

Autotel Race Radio  
0044(0)1508 528837

[www.raceradio.co.uk](http://www.raceradio.co.uk)



### The Difference is Clear



## Dunnell Engines

Duratec and Zetec engines and components for road and race

Duratec full race and rally applications



**duratec**  
Duratec Engine  
2.0-2.5 Litre  
200-330 BHP

**zetec**  
Zetec engine  
1.6, 1.8 & 2.0 litre  
175-270BHP

Knut Ove Borseth -  
2009 European Rally Cross Champion  
Using our latest Duratec RX series engine



Complete engine & component development

[www.dunnellengines.com](http://www.dunnellengines.com)

Tel: +44 (0)1449 677726 Email: [info@dunnellengines.com](mailto:info@dunnellengines.com)  
Unit 10 Tomo Business Park, Creting Rd,  
Stowmarket, Suffolk, IP14 5AY, England

Wm. C. Mitchell Software - Racing by the Numbers

Introducing version 4.02 of the WinGeo3 Suspension Geometry program with Force-based Roll Centers  
----- explained! -----



[www.MitchellSoftware.com](http://www.MitchellSoftware.com)  
800-844-7296 from USA and Canada  
125 East Plaza Drive, Suite 117

704-660-0330 voice  
704-663-0085 fax  
Mooresville, NC 28115 USA

# SBD Motorsport

Vauxhall, Ford Duratec & Hayabusa

MBE Management systems, kits & components available



**MBE9A8**

Fuel injection up to  
8 cylinders



**MBE9A4**

Fuel injection up to 4 cylinders



**MBE9A4i**

Ignition only up to  
4 cylinders

Unit 15, Red Lion Business Park, Red Lion Road, Surbiton, Surrey KT6 7QD  
Tel: 020 8391 0121. Web: [www.sbdev.co.uk](http://www.sbdev.co.uk). Email: [sbdmotorsport@btclick.com](mailto:sbdmotorsport@btclick.com)

New from Rowley Race Dynamics

3rd Edition

# An Introduction To Race Car Engineering Book 1

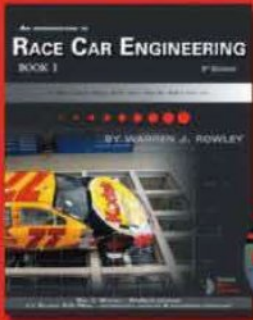

With the help of powerful software packages, this exciting new book provides the race engineer with considerable insight into the possible performance envelopes of a modern race car.



TO ORDER:  
[www.rowleyrace.com](http://www.rowleyrace.com)

**ATL**  
Tel: +44 (0) 1964 351990

Home Products Company Contact Links Information

**NEW ATL WEBSITE NOW ON-LINE**

Accessories to **ATL**

See the information also available in ATL in a large and handy online "Tech Support" system. Books describe the 3rd Edition in detail to include the full variation of products from our manufacturing development processes. The key to the development of ATL is the use of the latest software and hardware packages. This includes a large range of enhanced software and hardware packages for the latest engine technology and components. Additionally, we offer motor repairs and maintenance, engine parts and accessories, and a range of tools and equipment. The complete range of ATL products is available to purchase and also available with internet (lightning) light file data, and computer.

With ATL's range of products and high performance in mind, we have developed a range of products. All products are made to order. If you need any more information, please contact us on the website.

## MOTORSPORT QUALITY ROD ENDS AND SPHERICAL BEARINGS



broadest range in Europe  
metric and inch sizes

contacts in English,  
Deutsch, Français, Italiano

## INTERNATIONAL STOCKING DISTRIBUTORS **AURORA® · RODOBAL® · Seals-it®**

ACCESSORIES:  
side seals  
protection boots,  
jam-nuts  
bearing installation tools

Getecno srl  
16141 GENOVA - Italy  
fax +39 010 835.66.55  
phone +39 010 835.60.16

[www.getecno.com](http://www.getecno.com) - [info@getecno.com](mailto:info@getecno.com)

**CHASE**  
CHASECAM.CO.UK *CAM*

**THE NEW CHASECAM ONBOARD DATA MODULE IS HERE...**

**NEW! PRODUCT**

**Your PDR has just got smarter...**

The PDR 100 GF solid state digital recorder can now capture both high quality video **AND** record data!

Using our new **Data Module** and **Dashware** software, any PDR can record data from our 10Hz GPS, onboard accelerometers, vehicle sensors and even OBD2. Analyse raw data and view as graphics on the video. Custom graphic packages also available.

See our new products in action on The Ring video, go to the **ChaseCamTV** channel on YouTube or see our website [www.chasecam.co.uk](http://www.chasecam.co.uk) for further details.

[www.chasecam.co.uk](http://www.chasecam.co.uk)  
Tel : 0333 666 0366 or Email : [sales@chasecam.co.uk](mailto:sales@chasecam.co.uk)

## MSA / FIA COMPLIANT FUEL SAMPLING KIT FROM **THINK AUTOMOTIVE**

As of 2009 the MSA states in its Blue Book (page 150 [C(b)] 19) that cars competing in British + MSA titled championships must have a system built in that is capable of taking a fuel sample. Here at Think Automotive we have a variety of kits available to enable you to comply with both MSA and FIA regulations.

Prices start from:  
**£73.25**



**CALL US NOW ON:**  
**0208 568 1172**  
**OR VISIT:**  
[www.thinkauto.com](http://www.thinkauto.com)



# My career? It's in the fast lane.



**Become part of our success story.**  
**Accelerate your career with the BMW Group.**

## Chassis design engineer

Job reference: 59925

Join the BMW Group as a chassis design engineer in our motorsport department. In this stimulating role, you'll develop concepts and solutions primarily for race car suspension kinematics, as well as other complex components and assemblies. Ideally, you have several years of experience in suspension design for a premium motorsport category, so you're used to exploiting every inch of leeway afforded by the technical regulations. In this role, you'll turn your design solutions into engineering drawings using CATIA V5 and assist suppliers with production. You'll also be responsible for supervising the prototyping of your components in the workshop.

This is a challenging position encompassing a wide range of tasks, so we're looking for people with:

- A degree in automotive engineering, mechanical engineering or a similar engineering field.
- Several years of front-line professional experience.
- Experience and expertise in designing DTM, Formula 1 or Le Mans racing car prototypes.
- Expertise in FEM calculations for determining the strength and rigidity of suspension components.
- Proficiency in CATIA V5 and MS Office.
- The ability to communicate effectively in German and English. French would also be advantageous.
- Strong communication skills and able to work well as part of a team.
- A confident manner.
- Assertiveness.
- Initiative.

Want to swap stories, read up on application tips and find out more about careers at BMW? Then go to

 [facebook.com/  
bmwkarriere](https://www.facebook.com/bmwkarriere)

Looking for a captivating new challenge? To find out more details and apply online, visit [www.bmwgroup.jobs](http://www.bmwgroup.jobs).

**BMW Group**



## Simon Perkins

### THE INTERVIEW



**Simon Perkins**  
managing director, Willans

#### Company biography

Willans was set up in 1967 by retired British army officer Major Terrence 'Dumbo' Willans – a WWII paratrooper and post-war parachute tester – and Formula Junior racer John Fenning. They started to supply harnesses to F1 in 1969, but then they split the business – amicably – so that Major Willans (Google him, quite a man) could concentrate on fall protection harnesses, while Fenning stuck with the motorsport.

The company can boast that 19 Formula 1 champions have been kept safe and snug in its harnesses, while it's also chalked up some 250 grand prix wins. In 2007 historic racer, Simon Perkins, took over the business after Fenning announced he was to retire.

#### Q How did you come to buy Willans?

When I sold my previous business I took a year off and did the European Formula 2 championship [historics, with a March 712, he also owns a Crossle 16F FF1600]. And then I just decided I wanted to have a business that was related to motorsport. It took me a while to find the right company, but I'd always known of Willans because I'd always used their harnesses, and I heard a rumour that John Fenning, the previous owner, was looking to retire, so I went to see him and the rest is history.

#### Q How important are your F1 supply deals?

We've got four of the teams: Mercedes, Williams, Toro Rosso and Virgin. In fact,

we started off with Williams first, and then Toro Rosso saw the harness at a test day and contacted us and it went from there. Willans has been involved in F1 before, of course, but we weren't actually supplying any of the teams when I bought the business. Part of the condition when I bought the company was that John Fenning would help me introduce that product back into F1. Our F1 harness is a lot lighter, half the weight, or a bit less. The whole harness only weighs – well, we don't give an exact figure – but it's a lot less than a kilo. We also do NASCAR, IRL, V8 Supercars... In fact, we do all sorts.

#### Q How are you belts designed and tested?

We use 3D CAD. And we do a lot of destructive testing. We've got our own tensile test machine and we test every batch of every component. We stretch it until it breaks. And we photograph it and write a test report. We're very rigorous in our quality control because it's absolutely paramount, as lives depend on it.

#### Q What material are the belts made out of?

Top grade polyester webbing. That's the most important bit, and we're very careful about the weave and the strength of the webbing we use. It's all military grade. Polyester is the best material at the moment, but there is research going into new materials.

#### Q How do you make sure there's 'give' in the belts?

We have a preferred amount of stretch, because, yes, you need a little bit of give. It's all about the weave of the webbing and there are lots of factors that go into the weave – the actual pattern, the size of the fibres, the amount of fibres... There are certain inherent properties of the polyester, and then with the weave you can modify those properties within a given range.

#### Q Is there a difference between the webbing used in single-seater applications and, say, rallying, or circuit racing?

We use a range of webbings depending on the application, and also depending on the adjusters we're using as well. Some webbings just work better with particular adjusters.

## RACE MOVES

UK-based transmission specialist, Quaife, has taken on **Steve Prentice** as its head of design. Prentice has worked in engine and transmission design for 25 years, for companies as diverse as Jaguar, Lotus, Perkins, Prodrive, Volvo and Xtrac.

Veteran NASCAR crew chief, **Jay Guy**, is now responsible for the no. 38 Ford driven by Travis Kvapil in the Sprint



Jay Guy

Cup. Guy started the season as crew chief on **Andy Lally's** no 71 Chevrolet and last year he filled the same role for **Brad Keselowski**.

NASCAR veteran, **Doug Richert**, has replaced **Jay Guy** (see above) as crew chief for **Andy Lally** at the TRG Motorsports Sprint Cup outfit.

**Mike Coughlan**, the former McLaren design director who lost his job in the wake of the



Mike Coughlan

2007 spying scandal, is now working at Michael Waltrip Racing as director of vehicle design. We're told that MWR competition

director, **Steve Hallam**, himself a former McLaren man, was responsible for bringing the two together.

**Chris Saunders** has returned to Lola to work as its Technical Centre manager, rejoining the company after four and half years in F1 working for the Red Bull Racing and Toro Rosso teams. Saunders is highly experienced in wind tunnel work and was one of those responsible for Lola's own 50 per cent tunnel.

**Adrian Newey**, the only F1 designer to have penned cars for three championship-winning teams, has been awarded with the Segrave Trophy



Adrian Newey

for 2010. The trophy is awarded to a British subject with 'the Spirit of Adventure' for the most outstanding demonstration of transportation by land, air or water. It was created in 1930 to commemorate the life of racing driver and speed record breaker **Sir Henry Segrave**.

This year's Modena Terra di Motori Auto Show is honouring **Mauro Forghieri**. The show, which runs until 12 June, celebrates the Modena man's career with an exhibition entitled Thirty Years of

# Success Comes From The Connections You Make

## AS Heavy Duty



- Single way, high power connector
- 250 amps capability
- Available in 3 cable sizes
- Gold-plated, copper contacts.

## AS Series



- Full range of medium and high density circular connectors for motorsport
- Available in 3 - 128 way options
- Available in 9 shell sizes and 5 keyway variants.

## AS Double Density



- Unique next generation technology
- Allows a space saving of 2 shell sizes on a standard AS connector range
- Available in 5 shell sizes and a variety of keyway and gender options.

## AS Micro Fuel Immersible



- Updated micro for in-tank applications
- Unique elastomer seals developed by Deutsch
- Fuel resistant thermoplastic insert specifically engineered for racing fuels.

A S T E P A H E A D

Visit [www.deutsch.net](http://www.deutsch.net) for more information, a list of our worldwide distributors or to download a technical datasheet.

Alternatively call +44 (0) 1424 852722 or email [autosport@deutsch.net](mailto:autosport@deutsch.net)



DEUTSCH  
AUTOSPORT

# HOT ENGINE?

Improve your total engine cooling management

- ✓ More power
- ✓ Extend engine life
- ✓ Increase fuel efficiency

Davies, Craig brings you all you need for the world's most advanced total engine cooling management system:

- > The EWP® 115 alloy Electric Water Pump replaces or complements your existing mechanical water pump to release up to 13.4hp (10kW) which belt-driven pumps "steal", giving you increased fuel economy, more power, more torque.
- > Our Thermatic® Fan kits provide efficient and economical condenser (air conditioning) and radiator (engine) cooling.
- > The EWP® & Fan Digital Controller manages both the EWP® and Thermatic® Fan, continuing to run for up to two minutes after engine shut down (if above the targeted temperature), eliminating "heat soak" and extending engine life.

**EWP** ELECTRIC WATER PUMP



Turn 14 Distribution: 1-877-7-Turn14 • [www.Turn14.com](http://www.Turn14.com)

## RACE MOVES

Ferrari and Beyond. The exhibition is on show in the Modena World Trade Centre.

**Nick Fry**, the CEO of Mercedes GP, has been named as one of the



Nick Fry

British government's new business ambassadors, with the task of briefing ministers, ambassadors and United Kingdom Trade and Industry on British motorsport business.

**Zak Brown**, founder and CEO of motorsport marketing company JMI (Just Marketing International), has been named in the 2011 Forty under 40 awards and inducted



Zak Brown

into the award's hall of fame. *Sports Business Journal's* Forty Under 40 awards began in 1999 to pay tribute to flourishing executives under the age of 40 in sports business.

**Ryland James** has been appointed South Wales Regional Development Officer for the Motor Sport Association (MSA). Ryland is well

known within the Welsh motorsport community and his brief is to attract more newcomers into motorsport.

It has been confirmed that McLaren boss, **Martin Whitmarsh**, is to continue in his role as chairman of the Formula One Teams' Association (FOTA) for 2011.



Martin Whitmarsh

Renault team principal, **Eric Boullier**, is the new vice chairman, replacing Ferrari's **Stefano Domenicali** in the position. Red Bull Racing boss, **Christian Horner**, will maintain his role as chairman of the Sporting Regulations Working Group, with Ferrari's Aldo Costa taking over from Mercedes' **Ross Brawn** as head of the Technical Regulations Working Group.

**Martin Bartek**, the man behind the Matech Competition team, which developed the Ford GT into a successful racecar, has died at the age of 44. Bartek's Matech team won the FIA GT3 series in 2008 with the GT and was a front runner in last year's FIA GT1 World Championship.

**Norbert Singer**, the man who headed up the design teams that penned the Porsche

## Simon Perkins

### THE INTERVIEW

CONTINUED

#### Q What material are your adjusters made of?

The adjusters are forged aluminium. Our original adjusters are steel, but we have an increasing proportion of people buying our Silverstone range, which have the alloy adjusters, which are slightly lighter, but also a lot smoother to adjust.

The detailed design of it is quite important. We test our competitors' adjusters as well and some are not as good as others. We have a machine for this. The FIA requirement is you have to do 1000 cycles and then measure the amount of 'creep'. You're allowed 20mm, but we wouldn't pass anything that was more than 2 or 3mm.

But the biggest test is in Formula 1, because under braking they're pulling 5-6g, and that can be three or four times a lap for 60 or 70 laps, so you get a lot of loading cycles. That's probably the most arduous application.

#### Q What sort of technology is used in the manufacturing process?

In terms of the metal bits, all sorts of processes. In terms of the webbing, it's good old fashioned stitching. They are all sewn together, but we do use computer-controlled sewing machines. However, all the Formula 1 harnesses are handmade - again with a sewing machine - but this

time a manual one. We have very skilled and very experienced workers here, and it's all manufactured in the UK.

#### Q What other products do you manufacture?

We also do a range of fire suppression systems. We use a different technology in these. Most of our competitors use a flexible dip tube inside the cylinder, but we use a bladder. There are two main advantages to this. One is that the foam solution is inside the bladder and the pressurising gas is outside, so the gas is trying to squeeze the bladder. That means the orientation doesn't matter, whereas with the dip tube you're relying on gravity to keep the dip tube in the fluid, which may or may not happen. With the bladder system you're not relying on gravity at all, you have pressure acting in all directions.

The other interesting feature of the fire extinguishers is that because we use a bladder they maintain their pressure during the discharge, which is quite an important feature because it means the gas can't escape. It just squeezes the bladder but it can't get out, so you get a higher constant pressure, whereas with some of the other systems available the gas escapes and the pressure decays quite rapidly.



Willans products can be found all over motorsport as seen here on the Formula 1 World Championship winning Brawn BGP001's of 2009



# THANK YOU!

On Behalf Of Over 1,000 Exhibiting Companies,  
We At PRI Thank The Racing Industry  
For A Fantastic 2010 PRI Trade Show!



Steve Lewis  
Producer

Performance Racing Industry Trade Show



DECEMBER 1-3, 2011 • ORLANDO, FLORIDA • USA

[www.performanceracing.com](http://www.performanceracing.com)

## RACE MOVES

935 and 956/962, has joined the ACO as a consultant. The former Porsche engineer will be involved in the formulation of future rules and regulations and the policing of present rules. He replaces **Denis Chevrier** in the post, who has taken a position at the FIA.

Lola boss, **Martin Birrane**, and the head of the FIA GT1 World Championship, **Stephane Ratel**, have



Martin Birrane

both sold their shares in the company that owns the Le Mans Series, which is now owned by the ACO and the Peter Organisation.

**Campbell Roy**, a former business partner and friend of the late and great **Colin McRae**, has been taken on as sporting manager for the new Prodrive-run MINI World Rally Championship team.

**Tony Stephens** has been elected as club president of the Vintage Sports Car Club (VSCC). Stevens has served on the committee of the

pre-war racecar club for 11 years, and has been a member of the club for 40 years.

Ferrari has employed **Massimo Tammaro**, a former commander of the Freccie Tricolori – Italy's national aerobatic team – to help it improve its operations, teamwork and pitwall communications this season. The move is to help to avoid tactical mix-ups such as the mistake at Abu Dhabi that probably cost **Fernando Alonso** the world championship last year.

Grand-Am's vice president of competition, **Dave Spitzer**, is to shift the focus of his job on to 'future-oriented and

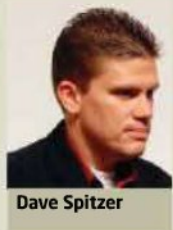

Dave Spitzer

international-based' projects, chiefly the new Daytona Prototype regulations, and a new series based on the DTM. The day-to-day running of Grand-Am will now be in the hands of managing director of competition, **Mark Raffauf**, and his team.

■ **Moving to a great new job in motorsport and want the world to know about it? Or has your motorsport company recently taken on an exciting new prospect? Then send an email with all the relevant information to Mike Breslin at bresmedia@hotmail.com**

## GRAVEL TRAP

# Our friends electric

For once, Sam is silent...



SAM COLLINS

**M**otorsport is changing. There is nothing drastic to see yet but here and there you can find a few signs. A couple of years ago I tested the University of Hertfordshire's UH13A Formula Student EV and the potential of the technology quickly became clear. The near silent running allowed it to be operated outside of circuit noise curfew for a start, which in turn opens up other venues for usage – like the car park at a local retail outlet, for example. They're largely unused out of shop opening hours and a green image would do their PR no harm. It's no surprise then that the manager of the Team Sport Karting centre in Bermondsey, London cites these exact reasons for deploying all electric karts at his new track. 'It was always our intention to go electric,' he tells me.

'With any central London location, running electric karts makes the planning permission process much easier. It is also better for the

customer – with no fumes the place does not smell and feel grimy and there isn't a film of oil all over everything.'

Whilst he doesn't say as much, it is clear that the new track is aimed at corporate events for firms based over the river in the City of London's financial district. These firms all have brave and wordy corporate and environmental policies and it would be hard to see how conventional combustion engine karts would comply with them. The potential for a PR own goal would be huge, but with electric karts that issue really goes away. The ventilation requirements for a venue running electric karts are much easier to comply with than those using combustion engines too. In fact, so much so that it's clear the former warehouse used by Team Sport would not be a viable location otherwise.

The track, built over two levels, is fairly rough and tumble, with mixed surfaces and even a jump as the track

goes up a level. As you drive around you can hear the kart creaking and moving around, whilst a quiet whine builds in urgency as your speed increases. Going over some of the bumpy sections of the course the kart crashes, bangs and sounds otherwise punished. But it is to some extent all bark and no bite, as without the clatter of the engine you hear all of the tiniest things, things which would otherwise be ignored. The lack of sound and fewer vibrations do make it somewhat more difficult to gauge how fast you are going, but does that detract from the experience? Not really. I think for someone who has driven other karts, it kind of removes some of the rawness and the aggression, but that's not saying that it's worse, it is just very different.

**a quiet whine builds in urgency as your speed increases**

The same is true for the handling. The Biz EcoVolt used by Team Sport has its lithium-ion phosphate battery packs mounted either side of the driver, giving a significantly different weight distribution to a conventional kart. Coming into some corners where perhaps the weight of the engine(s) and fuel tank at the rear could be used to help turn in, you feel initially like you are suffering from understeer. Lifting off the accelerator pedal is different too as the electric motor does not freewheel, rather it acts as a brake. So with the karts less tail happy it makes them rather more beginner friendly, though a little frustrating at first for those with experience.

Something else I struggled with were the short sessions. Team Sport has its karts set up to run for just eight minutes before the battery starts to fade, whereas I'm more used to driving for 40 minutes or more uninterrupted. 

## PIT CREW

**Editor**

Graham Jones

**Deputy Editor**

Sam Collins

**News Editor**

Mike Breslin

**Design**

Dave Oswald

**Chief Sub Editor**

Mike Pye

**Staff Writer**

Lawrence Butcher

**Contributing Editors**

Paul Van Valkenburgh

**Technical Consultant**

Peter Wright

**Contributors**

Chris Aylett, Andy Brown, George Bolt Jr, Alan Lis, Simon McBeath, Wouter Melissen, Danny Nowlan, Mark Ortiz, Roger B Phillips, Jef Richards, Martin Sharp, Ian Wagstaff, Paul J Weighell

**Photography**

LAT, Gavin D Ireland, Pete Lyons

**Group Sales Director**

Steve Ross

Tel +44 (0) 20 7349 3161

Email steve.ross@chelseamagazines.com

**Head of Business**

Development Tony Tobias

Tel +44 (0) 20 7349 3176

Email tony.tobias@chelseamagazines.com

**Senior Ad Sales Executive**

Lauren Mills

Tel +44 (0) 20 7349 3186

Email lauren.mills@chelseamagazines.com

**Publisher**

Luke Bilton

**Senior Publisher**

Sarah Arthur

**Managing Director**

Paul Dobson

**Editorial**

Racecar Engineering, Chelsea Magazine Company, Suite 19 Chelsea Wharf, 15 Lots Road, London SW10 0QJ UK

Tel +44 (0) 20 7349 1920

**Advertising**

Racecar Engineering, Chelsea Magazine Company, 26-30 Old Church Street, Chelsea, London SW3 5BY UK

Tel +44 (0) 20 7349 3150

Fax +44 (0) 20 7349 3160

**Worldwide Subscriptions**

CDS, Tower House, Sovereign Park, Market Harborough, Leics LE16 9EF UK

Tel +44 (0) 1858 438749

Fax: +44 (0) 1858 434958

**Subscription Rates**

UK £72 (12 issues)

USA \$135 (12 issues)

ROW £84 (12 issues)

News Distribution

COMAG, Tavistock Road, West Drayton, Middx UB7 7QE

Printed by Wyndeham Heron

**Printed in England**

ISSN No 0961-1096

USPS No 007-969



www.racecar-engineering.com

## LATE APEX

## Interventionism, part 2

It seems last month's Late Apex, dealing with some of the latest suggestions to 'spice up' Formula 1, has struck a bit of a nerve with readers. Broadly speaking, our respondents fall into one of two categories - one group thinks car design and specification are the main culprits in stifling an entertaining on-track show, the other considers circuit design to be the major hindrance.

One in the former group was Simon Mather who, to summarise, said the following: 'Two races into the 2011 F1 season and we've seen very little in the way of overtaking with DRS (and if it does work in China, then we may as well resign ourselves to a season full of Tilke-tracks), while the principal use for KERS seems to be as an alternative to launch control in getting great starts.'

'Rather than spending thousands creating gimmicks, maybe the FIA should be looking at removing some of the drivers' comforts. A return to steel brakes would extend braking zones to a distance where overtaking required skill rather than blind luck, and re-introducing a clutch and manual 'box would mean drivers had to concentrate on not making mistakes - on the actual art of driving rather than just pressing buttons - and again, this could provoke far more overtaking opportunities than a KERS system that failed unanimously once before to get into the sport and a Drag Reduction System that clearly hasn't worked so far.'

Then consider the following from former FIA technical consultant, Tony Purnell, whom we interviewed at the end of 2009 (V20N1). He was discussing a return to what he called the 'cigar tube' cars of the 1960s being viewed by some people as a way of allowing F1 cars to run close to one another without destroying their performance.

'The big culprit in all this is downforce,' he said, 'but you can't go backwards with downforce, as most fans would not be willing to accept lap times that are, say, 15 seconds a lap slower than they are currently, even if there is a big increase in overtaking. We'll therefore use electronics to get back to where we want to be with the cars in terms of their behaviour in the wakes of other

cars, and this will be acceptable.'

Clearly not entirely in agreement with the 'current track design is rubbish' camp, Purnell added, 'The situation will also be helped by better race track design, but that will have more of a secondary effect on overtaking, as it remains something of an imprecise science.'

So there you have the opposing views on this subject in a nutshell. Accepting the contention that downforce is a major contributor to the performance levels (and perceived problems) in modern F1, the difficulty is, you can't put the genie back in the bottle. Once Peter Wright, and others at Lotus, discovered the secret to unlocking the aerodynamic potential of a racecar's underbody, the sport was set on its

future course. Adding further complexity to the conundrum, many lesser single-seater categories - as well as a wide variety of other motor racing formulae - have taken their technical

cue from F1 and adopted high downforce underbody aero approaches to their chassis. Should the decision ever be taken to remove current levels of underbody aero in F1, the difficulty for the FIA is that grand prix racing, which views itself as the technical pinnacle of the sport, might end up with cars that are slower than their GP2 or F3 counterparts.

In that respect, Tony Purnell will be correct in saying that you can't go backwards technically, in which case the governing body has to work with what it's got in terms of both car and circuit design. Here's hoping they come up with some inspired thinking.

**EDITOR**

Graham Jones



the difficulty is, you can't put the genie back in the bottle

For subscription queries or to buy *Racecar Engineering*, go to <http://www.subscription.co.uk/racecar/> or [racecarengineering@subscription.co.uk](mailto:racecarengineering@subscription.co.uk) telephone 0844 243 0778 +44 1858 438443 (overseas)

• Racecar Engineering, incorporating Cars & Car Conversions and Rallysport, is published 12 times per annum and is available on subscription. Although due care has been taken to ensure that the content of this publication is accurate and up-to-date, the publisher can accept no liability for errors and omissions. Unless otherwise stated, this publication has not tested products or services that are described herein, and their inclusion does not imply any form of endorsement. By accepting advertisements in this publication, the publisher does not warrant their accuracy, nor accept responsibility for their contents. The publisher welcomes unsolicited manuscripts and illustrations but can accept no liability for their safe return. © 2011 Chelsea Magazine Company. All rights reserved.

• Reproduction (in whole or in part) of any text, photograph or illustration contained in this publication without the written permission of the publisher is strictly prohibited. Racecar Engineering (USPS 007-969) is published 12 times per year by Chelsea Magazine Company in England.

# Made for winners!



*innovative*



- Coilovers in 3 dampening variants
- Max. technical lowering
- With german TÜV-certificate



- Optimum performance on the race track
- With adjustable top mounts
- For the race track and the road



- Motorsport suspension for top-level motorsport
- 2- and 3-way adjustable
- Numerous motorsport successes



KW automotive GmbH  
Phone: +49 7971 9630-0  
[www.KWsuspensions.de](http://www.KWsuspensions.de)



KW automotive North America, Inc.  
Phone: +1 888 721 3888  
[www.KWsuspensions.com](http://www.KWsuspensions.com)



KW automotive UK Ltd  
Phone: +44 870 990 7536  
[www.KWautomotive.co.uk](http://www.KWautomotive.co.uk)

WINNER OF 2011  
MOST INNOVATIVE  
NEW MOTORSPORTS PRODUCT  
OF THE YEAR AWARD AT THE  
WORLD MOTORSPORTS SYMPOSIUM



ITS NO SECRET THE GERMANS  
HAVE SOMETHING WE ENVY...  
(Nürburgring)

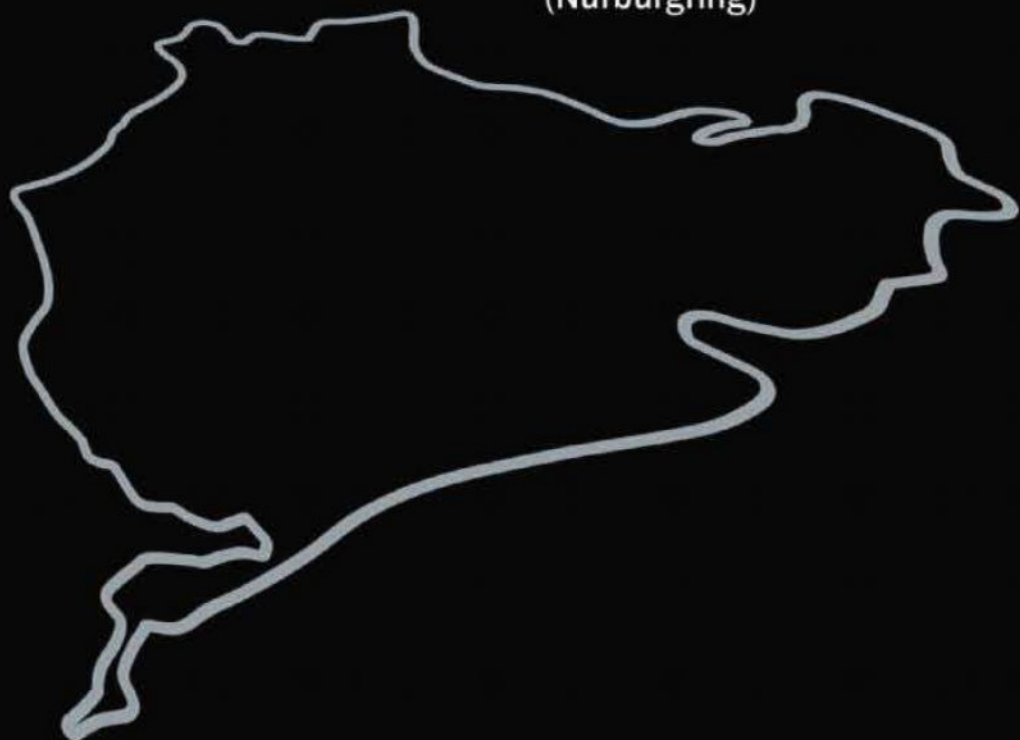

CONSIDER US EVEN.



**PERFORMANCE<sup>®</sup>  
FRICTION  
BRAKES**

USA 866.392.9936  
[www.performancefriction.com](http://www.performancefriction.com)  
[motorsportsteam@performancefriction.com](mailto:motorsportsteam@performancefriction.com)

**R43 ZERO DRAG  
Caliper System**

Custom Brake Kits starting at \$1995