

Leading-Edge Motorsport Technology Since 1990

# Racecar engineering™

August 2011 • Vol21 No8 • www.racecar-engineering.com • UK £5.50 • US \$12.50

## FERRARI P4/5

A 21st century version of an legendary racer

## TURBO CHARGING

Small capacity engines and compounding systems

## CARBON ENGINE

Americans take the next step in composite technology

# HOW LE MANS WAS WON



**Aston Martin**  
AMR reveals its LMP1 decision making process



**DeltaWing concept**  
Former Indycar plan gets Le Mans green light



**March 711**  
Ground breaking aero ahead of its time





# Our In-Line Filters Just Got Even Better. New Components. More Versatility.

## Modular In-Line Filters...Now Stackable!

Combine different filter elements into one stacked body for staged filtration that's unbeatable. Larger debris is filtered out in the first stage with a larger micron rated element. A finer micron element in the final stage finishes the job without congestion. A SMART DESIGN.



Sizes -6 through -20. Available with either AN end fittings or our HC Clamshell Quick Disconnect end fittings.

All filter bodies are 2.47" diameter.



New stacking adapters with differential pressure take-off ports attach to pressure gauges and measure pressure drop, letting you know when to change the element. Available with or without end cap.



Stacking adapters without differential pressure take-off ports available too.



NEW short filter body is 3" shorter than standard body. Uses the same mounting brackets and end cap configurations, either AN or HC. Also available without logo/graphics. A GREAT SPACE SAVER.



Pleated stainless steel elements in 45, 60, 75 or 100 micron screens. Optional 15 psi relief valve to override obstructions.



7100 SERIES CONFIGURATION Shown above with our HC quick-release clamshell ends and optional -10 female accessory port on the inlet side to accommodate temperature probes, specialty adapters, etc. GET CREATIVE.

Still More Options



7200 SERIES CONFIGURATION allows you to uncouple the filter body and drop in a new element in seconds.

## Get the ConneXion.™

## Space Saver Fuel Filters With Suction Strainers



Threaded body with "AN" inlet to metric end outlet. 120 mesh suction strainer included. Sizes -4 thru -10. For alcohol or gas. Also available with clamshell body and "AN" ends or clamshell body and clamshell ends.

#120 Mesh Screen Suction Strainer. Other micron elements available.



Threaded body with "AN" inlet and "AN" outlet. 120 mesh suction strainer included. Sizes -4 thru -10. Viton or EPR O-Rings included for alcohol or gas.

Space Saver Suction Strainer's metric outlet attaches directly to fuel pump with female metric threaded inlet ports. Excellent pump protection without restricting flow. Staged finer filtration on the pressure side of the pump is recommended to prevent cavitation, etc.



All space saver filter bodies are 1.115" diameter

Manufactured in the U.S.A.  
from quality domestic alloys.

Go to [www.xrp.com](http://www.xrp.com)  
for catalog downloads  
& new products

# XRP®

THE XTREME IN RACECAR PLUMBING

UNITED STATES XRP, Inc. sales@xrp.com tel 562 861 4765 fax 562 861 5503  
EUROPE James Lister & Sons motorsport@lister.co.uk tel 44 (0) 121 525 5800 fax 44 (0) 121 553 5951

Find more issues at [magazinesdownload.com](http://magazinesdownload.com)





It has taken months of wrangling and politicking, but finally Formula 1 has settled on its engine regulations for 2014. Throughout, it was clear that Renault was pushing for a solution that would be relevant to its production cars, and though there isn't a 1.6 litre turbo charged V6 in Renault's range, it seems to be a suitable compromise.

Efficiency is key to the new engine regulations, from Formula 1 to Le Mans, the WRC and WTCC, both of which adopted the Global Race Engine concept. For manufacturers involved in the writing of technical regulations, relevance is of equal importance. Renault wanted a four cylinder engine, Ferrari didn't.

The trend in racing and in production cars is increasingly for smaller capacity, turbo engines, and so in this issue we look at Variable Turbine Geometry (VTG) turbo charging units, as well as turbo compounding, which we think could be a viable solution for Formula 1 and Le Mans Prototype teams.

As a final part of our Le Mans coverage, we also take a look at the strategies employed by Peugeot and Audi at the 24 hours. Three cars against one stacked the odds firmly in Peugeot's favour, but they didn't take it and we examine precisely what happened.

In addition, we also have featured the Aston Martin AMR-One Le Mans Prototype. The car has had a difficult debut so far this season, at Paul Ricard and at Le Mans, but in this article, the Aston Martin Racing team has answered its critics.

Finally, as part of a new series, we look back at technical innovation that we now take for granted. The March 711 pushed the boundaries of streamlined aerodynamics in Formula 1, but compromises to the original concept doomed the car from the start. That doesn't stop it being an interesting idea, and we loved the link between Spitfire's elliptical wings and Formula 1.

**EDITOR**

Andrew Cotton

For more technical news and content go to  
[www.racecar-engineering.com](http://www.racecar-engineering.com)



**32 COVER STORY**  
Despite Peugeot keeping all three cars on track, Audi won Le Mans



**10 ASTON MARTIN**  
Why an open LMP1 with an inline six powering it is a good idea



**51 NISSAN**  
Zytek develop GT engine into LMP2 class winning powerplant

The International Journal of Motorsport Technology  
**Racecar**  
**engineering™**

**NEWS**

- 4 News**  
World Endurance Championship launches, so does a new Renault, while F1 argues another point

**FIRST PRINCIPLES**

- 19 Aerobytes**  
The influence of rear wing height on sports prototypes is explored in the wind tunnel
- 25 Consultant**  
When should you consider using an anti roll bar? Mark Ortiz looks at the do's and don'ts
- 29 Databytes**  
Comparing drivers can be a tricky task but Cosworth Electronics reveals some tricks of the trade
- 79 Danny Nowlan**  
Just which sensors do you really need to use? Perhaps not as many as you think

**COVER STORY**

- 32 Le Mans - the winning strategy**  
The hard fought Le Mans was won by race strategy, we explain how L'Ouest was won

**ENGINEERING SOLUTIONS**

- 10 Aston Martin**  
There have been many questions raised about the design of the AMR-One. We answer some of them
- 44 Delta wing**  
It was a step too far for Indycar but Project 56 will take to the track at Le Mans next year
- 51 NISSAN LMP 2**  
How Zytek and NISMO co operated to turn a Super GT engine into an LMP2 mill
- 56 Turbo Charger**  
Audi Sport has revolutionised motorsport turbine technology, read how they did it
- 62 Turbo Engines**  
Formula 1 will have a twin turbo future but not in the way you may expect
- 71 March re-visited**  
The March 711 was a brave early attempt at a aerodynamically efficient racecar
- 76 Carbon Engine**  
An engine block made from carbon fibre. No really

**INDUSTRY AND PEOPLE**

- 78 Industry**  
General Motors reveal Indy 500 plans, Team Lotus have lots of new partners, and why Bernie may sell up
- 41 Tech update**  
How Peugeot Sport developed an ultra low drag body for the 908 at Le Mans
- 93 People**  
John Doonan is appointed Director at Mazda Motorsports and tells us his plans. 'jiggy' Gornall tells us about 'ghost engineers' in Formula 2
- 98 Bump stop**

Subscribe to *Racecar Engineering* - find the best offers online  
[www.racecar-engineering.com](http://www.racecar-engineering.com)



## WORLD ENDURANCE CHAMPIONSHIP

# World Endurance Championship gets the green light

**The Automobile Club de l'Ouest** has signed a three year contract with the FIA to create a World Endurance Championship out of the Intercontinental Le Mans Cup in 2012. The contract, signalling the re-creation of the WEC for the first time in 20 years, was signed at the Le Mans 24 hours in front of the world's media and, while the finer details have yet to be ironed out, the move has initially been welcomed by major car manufacturers.

'It shows that we're heading in the right direction,' said Audi's head of motor sport, Dr Wolfgang Ullrich. 'Audi has been involved in sports prototype racing and the Le Mans 24 hours since 1999. Ever since then we have been energetically supporting the idea of a worldwide racing series for this particularly fascinating form of motorsport - always with the long-range aim of a new world championship.'

'After the ALMS and the LMS the creation of the Intercontinental Le Mans Cup by the ACO last year marked the first major step in this direction that is now seeing its consistent



continuation in the FIA World Endurance Championship. This leads to a further upgrading of our activities with the R18 TDI.'

The calendar for the WEC will follow that of the ILMC in 2012, and will include the Le Mans 24 hours. Subsequent years will see a calendar of at least six events, submitted to the World Motor Sport Council for approval.

Two races will be held in North America, thought to be the Sebring 12 hours and the Petit Le Mans, two races in Europe and two in Asia, although Peugeot has

already said that it will actively seek to block a race in Japan in favour of a race in Brazil. It is also thought that there is a race in India on the cards.

There will be titles for both constructors and drivers. GTE cars will also be catered for, with an FIA GTE Endurance World Cup which will run within the WEC.

The ACO will run the championship, which the FIA says was born out of a recognition that sportscar racing was an ideal environment for developing new technology: 'In establishing

this new category of motorsport championship, both the FIA and ACO are keenly aware it needs to be a laboratory for innovation and the development of new technologies, allowing motor manufacturers to express, through the rigours of competition, their ability to be inventive and, as this is an endurance championship, to also highlight their capacity to produce high quality and safe machines and components,' it said.

FIA president Jean Todt, who masterminded Peugeot's World Sportscar Championship win in 1992, said: 'I am delighted to welcome the return of the FIA Endurance World Championship, especially with a promoter like ACO. I am also very pleased to have a legendary race like the 24 hours of Le Mans as part of it.'

The Le Mans Series is expected to run independently of the WEC next year. LMS boss Patrick Peter has said that the series will retain its Le Mans branding, but says that he is looking at shorter races. 'I am a partner in the WEC and the LMS,' he said. 'The first step was to secure the WEC, and now I will work on the LMS.'

## FORMULA ONE

## Blown diffuser saga exhausted

The FIA has acted on its promise to ban the use of blown diffusers and the related engine mapping, from the British Grand Prix in July.

Details of the ban had not yet been released by the time *Racecar* went to press, but it is understood that new measures will limit exhaust blowing to just 10 per cent of throttle when the driver is off-throttle, compared to almost 100 per cent used by some teams.

Blown diffusers were initially banned before the Spanish Grand Prix, but the ban was delayed because of the complexities involved in remapping the engine.

The FIA's technical delegate, Charlie Whiting, said: 'An exhaust system is there for the purpose of exhausting gasses from the engine and when you're off-throttle, it isn't doing that any more. Therefore it's being used to influence the aerodynamic characteristics of the car.'

The FIA and the teams have agreed to top exiting exhausts for 2012, putting an end to the blown diffuser saga altogether.

Teams also found an agreement over the new engine regulations, proposed for 2014. Some teams, particularly

Ferrari and Mercedes, opposed the four cylinder engine concept, and teams have now agreed on 1.6 litre V6s.

The agreement had yet to be voted on by the World Motor Sport Council as *Racecar Engineering* closed for press. The move is expected to appease Renault, which was campaigning for engines more relevant to its production cars and was pushing for the four cylinder formula. Under the proposals presented to the WMSC, KERS would be retained.

Check out [www.racecar-engineering.com](http://www.racecar-engineering.com) for an update.

## CAUGHT

**Dave Rogers**, the crew chief on the No.18 Joe Gibbs Racing Toyota in the NASCAR Sprint Cup, has been hit with a US\$25,000 fine after the front-left of the car was found to be 1/16th of an inch below the required height tolerance at post race scrutineering in Pocono. The team was also docked six points from its tally in both the drivers' and the owners' championships

**FINE: US\$25,000**

**PENALTY: loss of six championship points**



## TANK WARFARE



**Panther Racing has moved** to refute accusations it cheated in the Indy 500 this year. Graham Rahal questioned the fuel cell capacity of the second placed car of JR Hildebrand, which almost won the event but crashed on the last turn, in comments published in USA Today. But Panther pointed out that both Hildebrand and Target Chip Ganassi driver Dario Franchitti pitted on lap 164, about the same time as the winner for the previous two years. Panther chief engineer David Cripps worked out the

numbers that would get his driver to the finish from here, and Hildebrand stuck to around 218-219mph laps. Franchitti, who had to stop for a splash and dash on lap 199, was circulating at about 220-222mph. Meanwhile, Panther team manager Chris Mower says that the fuel cell is a component that the IndyCar Series checks regularly before and after races and it would be impossible to get away with such a blatant flaunting of the regulations. Hildebrand limped over the line in second place.

## GT WORLD CHAMPIONSHIP

## Deadline looms for GT contenders

**The future of the FIA GT** Championship will be decided this month as series organizer Stephane Ratel has set his teams a deadline of July 18 to pay the entry fee of 60,000 Euros per car.

Few of his existing teams are willing to put forward the full sum of money, though many have offered part-payment by July. Aston Martin says that it can only provide cars to customers if the DBR9 is grand-fathered for a further year, and Corvette has been openly critical of Ratel's plans to combine GT1 cars with GT2 and GT3, levelling the performance through the complicated balancing system.

The GT2 cars will follow the rules of the FIA set in 2009, the last time the organisation had a category for the cars. If he does not have sufficient entries, the championship will finish at the end of this year, and Ratel will concentrate on the GT3 European championship and his new

Blancpain series.

Aston Martin says that it will support the championship, but says that it does not have time or resources to develop the Vantage. 'We haven't got another car for it. We can only do the Vantage for 2013,' says Aston Martin Racing and Prodrive Chairman David Richards, whose company is also working on the WRC Mini and the AMR-One Le Mans car.

'We have got a GT3 car, which will be ready in August, so that is a proper programme, with a proper lead time and it will be sorted. It is built to GT3 regulations, and that is all we are going to do with that car. We have had some problems with the GT2 car, and have had to take a step back to the normal cross-plane engines. We would like to resolve that and have it ready by Silverstone [in September], and so we haven't got the resources to adapt that to new regulations. Our focus is to get that sorted.'

Corvette was similarly critical

of the proposal to performance balance the cars up to GT1 levels, and says that it would prefer to see the GTE class cars, under ACO regulations, form the basis of a GT World Championship.

'We would like to see the current GTE cars with a stable rule platform and a minimal balance of performance be the basis for the World Championship,' says Corvette Racing's Doug Louth.

'It's a great platform to take to a world championship. The idea of taking GT3, old GT1 cars and GTE and putting them all together in a series and balancing the performance, that just looks like chaos. Because there is no stable rule platform, the balance of performance would be impossible. Even if they did balance it at one track it would be completely different at another.'

'With the current GTE cars it would be a fantastic series and a big win for sportscars in terms of interest and exposure.'

## BRIEFLY

**Toyota secret tests**

It's been reported that Toyota has already started testing its hybrid LMP1 car in secret, and that the car actually hit the track as early as last year. The car, which has been built for Toyota by famed Japanese racecar manufacturer Dome, could race at Le Mans in the next two years, although it's believed that plans have been hit by the earthquake in Japan. The Japanese car giant is also looking into the possibility of offering a GTE car based on its Lexus LFA, a version of which has been tested at Valencia recently, we understand.

**Lola F3 return**

Lola is evaluating a return to Formula 3 in 2013 with an all-new design that aims to break the stranglehold of Italian constructor Dallara. Formula 3 remains one of the few remaining open single seater formulas. The car will be designed to the new regulations coming in next year. Lola was last in F3 from 2003 until 2007, firstly in partnership with Dome in 2003 - the car then called a Lola-Dome - and then with a wholly Lola-branded car from 2005. The car won races in the Italian, the Japanese and the British championships.

**Enduro for BMW DTM?**

BMW is looking to enter its DTM car in long distance races, if it can find events that will accept the cars. 'All of the components have a long life. The engine has to last for the entire season so it would easily do 6,000km - 7,000km, which is a 24 hour race distance, and that is an option for the future,' explained the firm's outgoing motorsport boss Mario Theissen. DTM is introducing all new cars for next season, which will use a spec Dallara carbon tub as their basis. Super GT and Grand-Am have both been linked with classes for the four door German cars but no announcements have yet been made.

■ MORE NEWS ONLINE AT [WWW.RACECAR-ENGINEERING.COM](http://WWW.RACECAR-ENGINEERING.COM)



# QUALITY AND RELIABILITY



## HIGHER FLOW RATES LESS FRICTION MORE POWER

With more than 40 years of experience manufacturing high performance racing valves, Supertech utilizes the finest material and design to make available the most durable, high performance racing valves on the market today. Supertech valves are forged, CNC machined, and hand polished for strength and reliability.

All Supertech parts are measured against the strictest tolerances in the industry and utilize finite element analysis, enabling us to provide a high performance product, without sacrificing durability. Regardless of your high performance needs, Supertech is the best choice for you if quality, durability and performance are vital to your needs.



3580 Charter Park Dr. San Jose, CA. 95136 USA (408) 448-2001  
[www.supertechperformance.com](http://www.supertechperformance.com)



## WORLD SERIES BY RENAULT

# New World Series by Renault car is DRS'd to impress

The new for 2012 World Series by Renault (WSR) car is to be equipped with an F1-style DRS wing and a brand new full race spec engine, the latter courtesy of Zytec, but will retain its current Dallara chassis.

WSR, which is also known as Formula Renault 3.5, occupies a rung between Formula 3 and GP2 on the drivers' ladder to F1, and

the third version of the car has been designed by Renault Sport Technologies in conjunction with Dallara. A decision to stick with the existing Dallara T08 chassis has been made to control costs, but 60 per cent of the car is still to be remodelled.

Headline changes include the move to a Zytec V8 engine which has been specifically designed for the car. The 3.4-litre V8, code named ZRS03, will generate 530bhp at 9250rpm, 50 more bhp than

the current Solution-F prepared Renault production-based V6.

John Manchester, Zytec Engineering operations director, said: 'Zytec is extremely privileged to have been chosen as the engine manufacturer for such a high profile racing series. To have the opportunity to form a partnership with such a respected brand as Renault is indeed an honour. Zytec has over 16 years of experience supplying engines for single-make racing formulae and we are sure that we can make a contribution to help make what is already a very successful racing series even more successful.'

Other notable aspects of the car include a radical ECU built by XAP Electronique which does away with the need for a battery - it's claimed it's the

first single seater to run without one. There's to be an anti-stall system fitted to make up for the lack of a starter.

To encourage overtaking the car will be fitted with an active gurney, which will serve to reduce aerodynamic drag, in the same way as the Drag Reduction System (DRS) in Formula 1. At the press of a button the driver will be able to activate this system on the straights to achieve gains of up to 12mph.

The car's new aerodynamic package, in particular its new front and rear wings, could gain 34 per cent more downforce, claims Renault Sport, while other changes include a new 6-speed gearbox and pneumatic gearshift.

Michelin has developed brand new tyres for the formula, too, which with the engine and aero updates should see the car lapping most circuits as much as two seconds faster. Running costs are expected to increase by around 60,000 Euros per season over the current 600 to 800,000 Euro budgets.



The new Dallara built World Series Car will race next season

## NASCAR

## NASCAR update: 2013 Ford takes shape

The racing world will get an idea of how the new-for-2013 Ford NASCAR Sprint Cup racer will look very soon - even though the car will not make its track debut for 17 months.

That's the word from Jack Roush, co-owner of Ford-running Roush Fenway Racing, who says the new car will have a definite and recognisable Ford identity, thanks to NASCAR's efforts to allow the cars to be designed around 'hard points' - where each manufacturer's chassis needs to be to the same dimensions to ensure aero parity - yet still retain their manufacturer's DNA.

Roush said: 'For instance, it will be a common roof even though the quarter windows will be different. It will be a common deck lid configuration even though the rear fascia will be different. The side-panels,

the door sides and quarter-panels and fenders will be brand identifiable, but the areas around the wheel wells and the areas around the front and rear fascia contacts will be exactly the same.'

He added: 'I think there has been a great effort made to give as much room as possible for the manufacturers to show the brand identity things that are of interest to them, while at the same time maintaining parity in regard to performance.'

Roush said that the first 'marketing and image' versions of the 2013 car should be rolling out of the body shop within the next few weeks.

Meanwhile, mobile phone company Sprint is in talks to extend its title sponsorship of the NASCAR Sprint Cup series beyond its current contract, which is set to expire in 2013.

## FORMULA 1

## F1 minnows up aero effort

Two of Formula 1's newer teams have taken steps to move up the grid by changing their approach to aerodynamic development.

Both Team Lotus and Virgin Racing have made changes recently, the most drastic being the latter's split with Wirth Research and its eponymous boss Nick Wirth. The breakup comes after a review by former Renault director of engineering Pat Symonds - who is currently a consultant at Virgin.

Wirth's approach had been to rely totally on CFD rather than wind tunnel development, but the team has failed to improve its performance following a disappointing first year in 2010, and has now been left behind, in performance terms, by fellow new team Lotus. It's rumoured that Virgin is looking for a technical tie-up with McLaren, similar to that which Force India currently enjoys, but in the meantime it will now start a wind

tunnel programme.

For its part, Team Lotus has announced that it's expanding its wind tunnel operations having confirmed a deal with Williams F1 to use one of the Grove-based team's two wind tunnels from September 2011. Team Lotus will now be running a two tunnel programme, with the Aerolab facility in Italy working in conjunction with the Williams F1 site in the UK, while work continues on the team's own wind tunnel at Hingham. When that facility is operational all activity will be transferred to the team's own site.

Tony Fernandes, Lotus team principal, said: 'From a practical perspective there are the obvious benefits of increasing our wind tunnel activity and using a state-of-the-art facility in the UK, and I am sure that will immediately help Marianne Hinson [head of aerodynamics and CFD] and her team of people to work even more effectively.'





# We Help You To Push The Envelope

There are those who equate success in racing to the ability to "push the envelope" further than your competitors. Innovation has its rewards.

When it comes to fasteners, one firm is eminently qualified to provide you with the design, engineering and manufacturing support needed to advance your programs with complete confidentiality; ARP®.

For over 40 years, ARP® has helped race teams, engine manufacturers and professional builders in all forms of motorsports the world over to achieve race-winning performance and dependability.

And while we're best known for manufacturing engine related fastener components, ARP® has the expertise to design and manufacture application specific fasteners to meet your needs. Our on time delivery record is second to none.

Our 100-page catalog contains the automotive aftermarket's largest selection of off the shelf, application specific performance fasteners. If you don't see what you need, please contact our factory technicians for personalized assistance.

Our R&D capabilities are extensive, our factory is AS9100 and ISO-9001 certified, and we share your passion for winning.



**ARP**  
automotive *Racing* products



**1-805-525-1497 • [www.arp-bolts.com](http://www.arp-bolts.com)**

1863 Eastman Ave., Ventura, CA 93003, USA • Local: 805-339-2200 • Fax: 805-650-0742





WORKSHOP TOOLS

## FACOM ROLL CABS

**Facom Tools** has released a range of new roller cabinets and top-chests featuring some innovative design details which they say challenge traditional and restrictive workshop storage facilities. The company has gone back to the drawing board to produce a multitude of designs, in three widths with up to 11 drawer combinations. Innovations include features such as retractable edges to accommodate large objects, wheels which only require a seven kilogramme force to move

the unit, handles designed to counter slippery hands, fast tool access and soft bumpers to absorb shock and protect vehicles. Each unit can be custom configured with a flexible number of drawers per cabinet and modular tool storage for each drawer. All of the work surfaces are made of 2mm thick, ribbed, pressed aluminium which is also reinforced with a 15mm wooden board for ultimate strength and durability. **For further information visit [www.facom-tools.co.uk](http://www.facom-tools.co.uk)**



ELECTRONICS

## PLASMA PROJECTS COILS

**Plasma Projects**, who are the exclusive European distributor for Okada Projects ignition components, has released the Plasma Direct range of ignition coils with built-in high-power amplifiers.

The company claims that these coils provide an improvement over others on the market, with potential power and economy benefits. The Plasma Direct coils produce twice the spark current and four times more spark energy than most stock coils, and generates an ultra-fast multi-spark discharge of 10 sparks up to highest rpm. The Plasma

Direct coils are all OBD II compliant and fitment simply involves removal of the OEM items.

**For more information see [www.plasmaprojects.com](http://www.plasmaprojects.com)**



ELECTRONICS



## SUPER B BATTERIES

**Lithium batteries** are growing in popularity in motorsport markets, thanks to their exceptional light weight. Battery development is an area of growth, and Super B are the latest entrant to the market with their range of LiFePO4 based batteries, designed for use in applications ranging from ATVs to racing cars. The smallest car-specific battery is the Super

B10P, weighing in at 1.75 Kg and designed for cars up to 1600cc with alternators or 2000cc without. Capable of producing 600 cranking Amps, the B10P is ideal for use in a wide range of single seat and closed racecars where both space and weight are at a premium.

**For more information go to [www.super-b.com](http://www.super-b.com)**

BOOK REVIEW

## COMPETITION CAR AERODYNAMICS, A PRACTICAL HANDBOOK

**The first edition** of Simon McBeath's 'Competition car aerodynamics, a practical handbook' has proved to be an invaluable tool for many racers looking to gain a better understanding of their car's aerodynamic performance. The key quality of this publication is McBeath's ability to convey the intricacies of fluid dynamics and principles of downforce generation in a way that the majority of readers can comprehend, without in any way dumbing down the subject. This second edition draws on the considerable advances made in the field of competition

car aerodynamics, with the author having had access to a wide range of state-of-the-art facilities, including the latest CFD packages and the full-scale MIRA wind tunnel. Included are case studies encompassing all forms of vehicle, from clubman saloons to Formula 1, which include many examples of quantitative data showing the real world impact of aerodynamic changes. Overall, this second edition brings the reader right up to date with the latest aero developments and, more importantly, how this knowledge can be applied to their racing programs.



# Uncommon engineering

How Aston Martin Racing developed a brand new and highly innovative LMP1 in six months and on a tight budget

**A**ston Martin Racing has come in for a lot of criticism over the development of its LMP1 challenger, the AMR-One, but the team is stoically sticking to its guns and says that by Silverstone's Intercontinental Le Mans Cup event it will have taken a large step forward. A revised engine design should be in place by then, along with updated aerodynamics, and the team can get on with some serious testing ahead of what should be a more competitive season in 2012.

The Le Mans 24 hours in June was a disappointment for the team, which has developed Prodrive's first ever ground-up engine and chassis combination in just six months. The team has previously run a modified Lola Prototype alongside its fleet of

BY SAM COLLINS

self-developed GT cars but, in September 2010, Aston Martin Racing's Team Principal George Howard-Chappell was given the green light to develop an all-new car for the new LMP1 formula. 'We had had three years of experience of the Lola Aston Martin so we could have chosen to run another year with a grandfathered car, but we wanted to control every single design aspect and going for somebody else's chassis doesn't give you that freedom,' said Howard-Chappell. 'In the past we had our difficulties with Lola, when you are not in control of the chassis and you can't decide what to homologate, or can't do it when you want to. Also, the name above the garage counts.'

## OPEN OR CLOSED?

Although minor design work had already started when the programme officially got off the ground, some key choices were still to be made about the car. 'There were two fundamental decisions to make and they were whether we would build an open car or a closed car and what kind of power plant we would use,' said Howard-Chappell. The choices made were controversial - an open-top chassis propelled by a 2.0-litre, turbocharged, in-line six. Although the only other works cars (Peugeot's 908 and Audi's R18) built to the new regulations were closed cars, and both manufacturers claim a clear advantage from that format, Howard-Chappell feels differently and claims that tyres were a key factor: 'Driver changes are massively better in an open car





“ we wanted to control every single design aspect ”

and, with the number of stints you can do at Le Mans, you may well need to change the driver when you are not changing tyres, so you pick up time on the closed cars there.’ With Audi managing to run five stints at Le Mans on the same tyres, and Michelin working hard at increasing the life of its rubber, it is likely that Aston Martin Racing has found something of an advantage for 2012 and 2013 with this solution.

Howard-Chappell concedes the closed cars have an aerodynamic advantage, but says the benefit is small. ‘In a pure aero sense, there is lower drag and, if you are clever, there is a little more downforce available. But we are talking about very small amounts in the study we did. You may also have a bit more structure with the closed cars, but we are not struggling for stiffness, and the mass of our

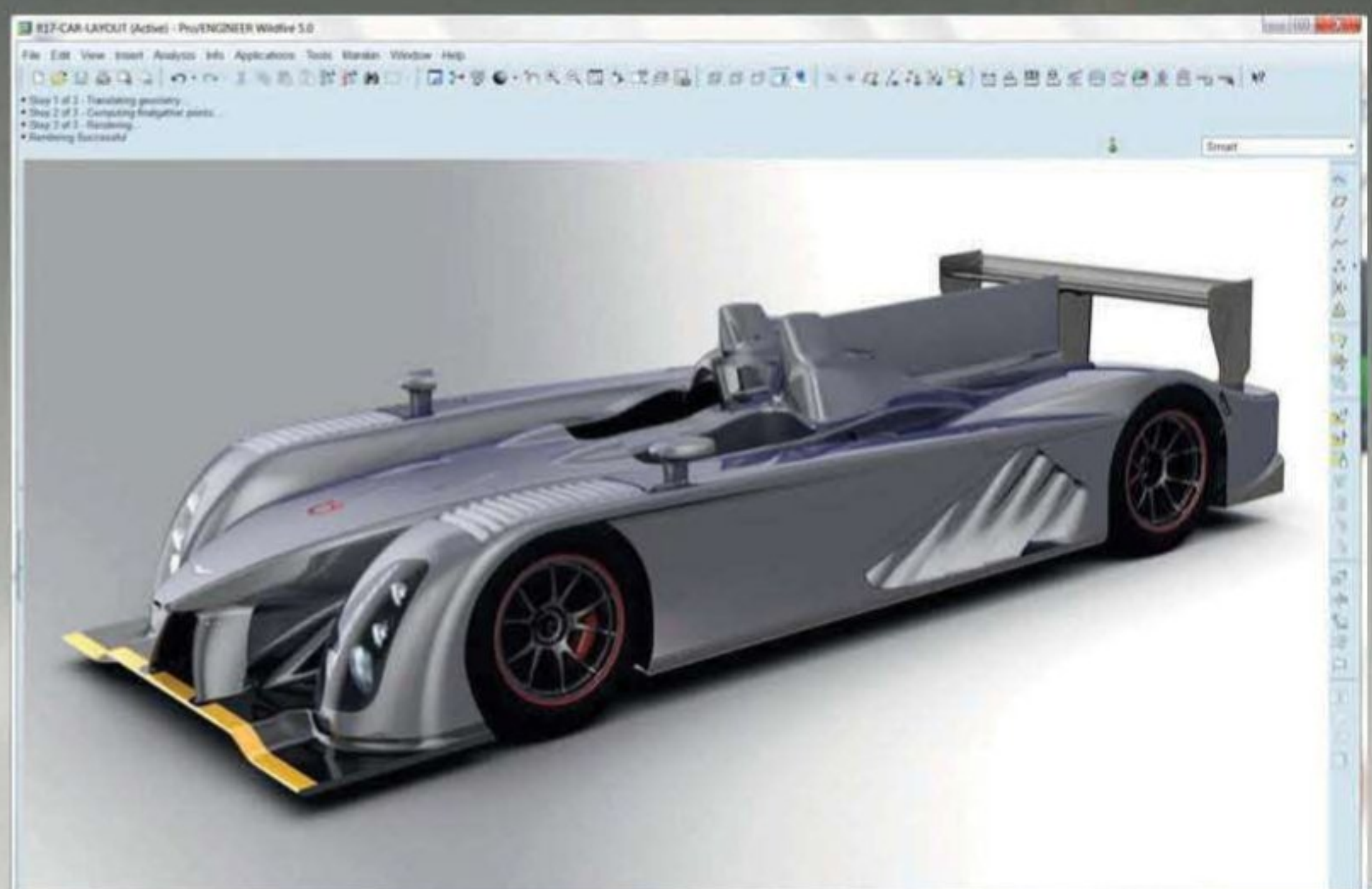

Utilising the resources of its partner, PTC, AMR modelled the car first using its new Creo CAD package





Double wishbone suspension layout is conventional, but there's a complex ducting arrangement that controls airflow through and around the rear of the car

monocoque may be a bit lower, but there is not much in it. One big thing with the closed cars is visibility. If you get rain and oil on the 'screen you are screwed in a closed car, while on an open car it's just a visor tear off. This is a car for both us and our customers and, with the mandatory air conditioning regulation going away, when it gets really hot you'll see the drivers outside of a proper works-team fitness programme not being able to cope.

'Doing a closed car also gives you the additional complexities and cost of designing doors, windscreen, wiper and ventilation systems. If you put all of that effort into another area of the car that makes you go faster, you end up in the same place or better, unless you have infinite resources, and we do not. You have to choose how to spend your time and money.'

**PARTNER COMPANIES**

To maximise resources, Aston Martin Racing partnered with a number of companies, including PTC, who allowed the team to use its new Creo software package to design the car,

despite the fact that it was not even released at the time. 'It was a bold move, but we were happy to do that. It's a good partnership on both sides and, to be honest, that hasn't given us any grief at all, we are really happy with it,' enthused Howard-Chappell. Other partners include TotalSim for CFD and rapid prototyping firm, Stratasys. 'A technical partnership works on two levels - one is effectively a fast route to technology that helps you move along, and two is the potential cost saving. Some of these things are available, so you could just go out and buy them but, if you can get it through a technical partnership, or sponsorship, and get the gain as well, then that's a saving all around. And it is ultimately the job of a technical director to make the fastest, most reliable car for your budget.'

Overall, the AMR-One has a fairly conventional chassis with double wishbone suspension front and rear, and most other systems being modified or updated versions of existing technology. 'All round, the gains to be had in the mechanical design of the car, through doing



Driver controls were mocked up in the early development stages using the Stratasys Dimension 3D printing machine, then manufactured in house

something revolutionary, are very small. But that's not what makes these cars tick. We have gone for something where we have very nice geometry, good stiffness and good control, and that's what we wanted. We believe that what we have is a nicer solution than what we had on the Lola. The bits are lighter, for example. On the Lola we never ran the car with three springs and dampers front and rear, but it works very nicely on this car. We never found the gain on the

old car, partly because it was not designed for it. It was a later addition. We are very objective about these things, and are not going to bolt something on just because it's what everybody else runs, or because people tell you it is supposed to be faster. We will do it when it is faster, and that's what we found with the AMR-One.'

One area where Aston Martin has followed the pack is on the front tyre size, with Audi, Peugeot and Lola following the





Engine location is not stressed, but is supported by a triangulated structure that picks up on the bellhousing



Being an in-line configuration rather than a V, engine layout is asymmetrical, with the plenum on the right-hand side and exhaust on the left

lead set by Nick Wirth's Acura ARX-02 on running much wider rims. 'That was an interesting one because it's obviously a function of what you are going to do weight distribution-wise,' reveals Howard-Chappell. 'There is a drag penalty for the bigger tyres, and the main factor in the decision to use them was that the other two big teams were going that route, so that's where the tyre manufacturers' development is going to go. We didn't want to spec something where we would be left behind. This car has got at least a three-year life and we

need to be getting the latest tyres on it to be competitive.'

#### RELIABILITY ISSUES

The AMR-One had a difficult introduction, with testing and its early races blighted with reliability issues but, while the team is disappointed, it admits to not being entirely surprised. It is, after all, the first car Prodrive has developed fully from the ground up, rather than basing it on a pre-existing design (such as with the Aston Martin DBR9). 'It is a big step,' admitted David Richards, chairman of Prodrive and Aston

Martin. 'Maybe we should have gone more slowly into it, maybe we could have put an interim engine in the back or just bought an engine whilst we develop the six, but all of those things cost extra cash. And sometimes in life you have to make commitments about things. We utilised all of our resources to their capacity and maybe a bit more than our

**“ sometimes in life you have to make commitments about things ”**

capacity.' Undertaking the project at a time when the company was fully engaged in the design and development of the MINI WRC may have been too ambitious too, according to Richards. 'If there is one issue that has compromised this, it is the fact that the two programmes have been running in parallel. It wasn't about the design side, it was about when we came to manufacturing. Over the last three months we have had a big fight for resources. All our capacity was taken and, at the same time, all of the Formula 1 teams are looking for spare capacity as well, so we couldn't outsource anything. Our composites division has been

working 24/7 for four months, all 88 people. Everyone has been going flat out to produce parts. Motorsport has gone through this funny period where, over the last three years, everyone has de-stocked, run resources down, kept overheads and personnel levels very low, then suddenly we are looking for outsourcing, and you just can't get it at the moment. It has been a nightmare.'

#### COMPANY PHILOSOPHY

But it seems that the AMR-One programme is coming out the other side of its early problems. Rival manufacturers' technical staff go out of their way to point out that the other two works teams probably have the same issues at this stage of their programmes, but they do it in private. Aston Martin Racing is ironing out the bugs and getting the car right before it releases it to customers.

'The philosophy of everything we do, and the way we work it across every project we have ever worked on at Prodrive, is that we never hand over a car to customers unless we have operated it ourselves for a period of time. By the time it goes to them, the specification is sealed, there is no change. If the customer wants to make changes it is up to them, but we will not

do any further changes after that point in time. Consequently, what you see in the GT2 cars is a product we have developed and handed over and, to be fair, we have not run that car enough ourselves, certainly not compared to the GT1 car which, when you see it in the World Championship, doesn't require putting a spanner on it. It just runs and runs. The GT4 car is the same and the new GT3 will be run by ourselves until the end of the year. It is the same with the LMP cars.'

Just six examples are being built, and all of them have been sold ahead of time, such is the lure of a genuine Aston Martin Le Mans racer.





## *New Products from Hewland*

### **MLG**



Designed for front engine, rear wheel drive  
6 speed sequential / Semi-auto option  
Capacity: 320 lbs. ft (435Nm/44Kg.m)  
Aluminium casing

### **LWS**

Designed for mid engine race cars  
6 speed sequential / Semi-auto option  
Capacity: 690 lbs. ft (935Nm/95Kg.m)  
Magnesium or Aluminium casing



*Contact Hewland to learn more about what is on offer in 2011*

- *A large and varied range of gearboxes to suit most needs*
- *High quality component manufacture, including gear grinding*
- *Concept design and manufacture of transmissions*

**KNOWLEDGE, EXPERIENCE, QUALITY**

**[www.hewland.com](http://www.hewland.com)**

Waltham Road, White Waltham, Maidenhead, Berkshire, SL6 3LR UK  
Tel: +44 (0)1628 827600 Fax: +44 (0)1628 829706 email: [enquiries@hewland.com](mailto:enquiries@hewland.com)

Find more issues at  
[magazinesdownload.com](http://magazinesdownload.com)



When Aston Martin Racing (AMR) was given the green light for the AMR-ONE programme one of the major issues it faced was what kind of powertrain to install. The choice of an in-line six harks back to the famous Bentley-designed Lagonda six fitted in modified version to the Le Mans-winning Aston Martin DBR1. However, in the modern era, such an engine layout is rare, especially in turbocharged form. This choice has put Aston Martin's engineers in the firing line for a lot of criticism. David Richards reveals that he thinks much of it should be taken with a pinch of salt. The teams that are questioning the layout are both diesel teams,' he said. 'If you are trying to argue the case, that the equivalency is right, you would say 'if they used a proper petrol engine then they would get equal performance but because they use a crap design that's why they are not equal to us.' It is a very political answer. Even the ACO said that if we used a proper engine we would have more power. We told them that is completely wrong, and that they should show us the science that tells them that.' To show us the science, AMR's engine boss Jason Hill explains the 6-cylinder engine design concept.

'What people need to understand with this engine is that when we talk about development problems, we need to make clear that the engine does not suffer from any sort of epidemic. We are doing a completely new engine, from a clean sheet of paper. We started running it in January and, when you look at our competitors, they have a clear process of six months from when the engine is run to when it goes in a car. We had to have ours in the car in February. Believe me when I say that the guys running round with four rings on their car would have the same problems, but they do it behind closed doors... we are doing ours on track.'

### SIX OF THE BEST

When AMR announced that its new LMP1 contender would be powered by a small capacity, straight six engine, there were more than a few raised

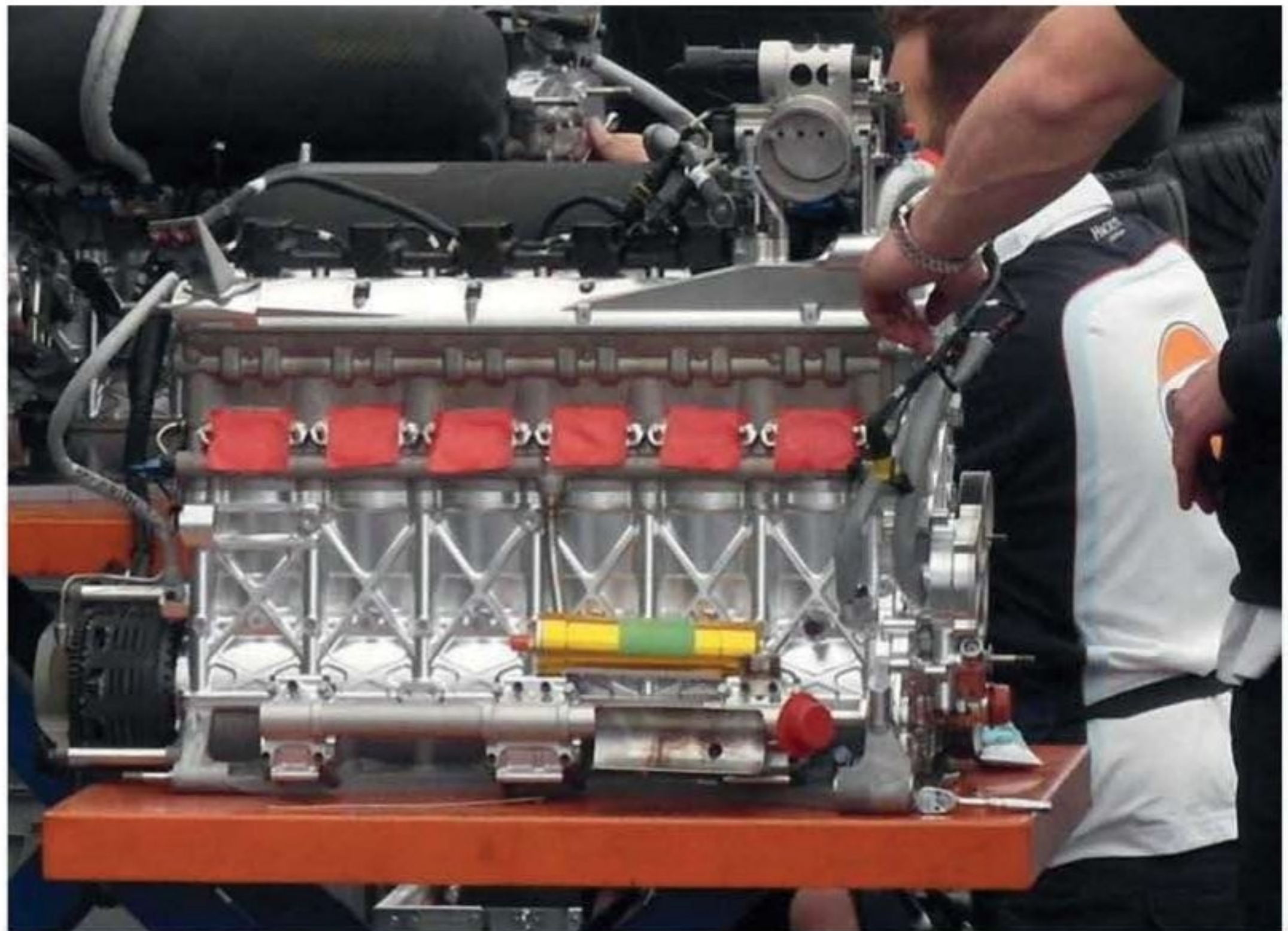

The doubters were quick to criticise AMR's choice of a turbocharged in-line six, but the company are convinced of its worth, stating that individual cylinder loads are lower than with a four cylinder, and its installed height is lower, too

eyebrows. It has been several decades since such an engine configuration appeared in racing, and is a major departure from the large capacity, naturally aspirated V12 of the DBR9, and later the Lola Aston Martin powered by a modified version of the same engine, featuring direct fuel injection. However, the selection of such an unusual configuration is not as strange as it might first appear, as Hill explained: 'There are several key reasons for opting to go with the straight six. Predominantly, you cannot look at the engine in isolation, you need to look at the complete package. In terms of establishing the architecture, you have to look at the peak cylinder loads and peak bearing loads. If you need larger bearings then this will affect the installation height of the engine and the overall packaging. So you have to ask what the advantages of a four over a six really are. Okay, it is shorter, but the car is 5m long so you are going to end up with a space behind the engine. Though the six is longer, the installation height is reduced and the individual cylinder loads are decreased. The only area [where the four has an advantage] is friction but, if you do the work, there is not much in it between



A single turbocharger configuration was chosen, but early tests with an inboard location caused problems with heat management and power potential, so an outboard location was run at Le Mans. The team are currently working on a new iteration of the system

the two configurations.'

With the engine layout decided, Aston Martin had a short time to design and build the new engine. Although initial plans were laid out for factors such as crankshaft geometry and general architecture in 2009, no real design work could be completed

until the project was confirmed in 2010. The first engine then ran on the dyno in January 2011.

### DIRECT INJECTION

The intention was always to run with a direct injection system, and AMR opted to utilise Bosch Motorsport's customer system,



which the company is able to tailor to individual applications. The direct injection system developed for the V12 engine also provided the designers with many valuable lessons in terms of port design and combustion chamber shape, but the addition of a turbocharger was new territory. Due to the high boost pressures and 9000rpm potential of the engine, the injection system available at the time was right on the limit of its capabilities, a problem that would have been compounded if a four cylinder with even higher cylinder pressures had been selected. As it stands, the injectors run at approximately 200bar of fuel pressure, which is required to provide the correct spray pattern needed for a homogenous charge at high rpm. Future developments are on the cards to utilise new injectors that will soon be available, and with manufacturers looking to develop components for the next generation of F1 engines,

pressures of over 400bar may be possible.

Another problem facing the engine team were constraints caused by the aerodynamic packaging of the car, especially in relation to turbo location. Initially, an inboard location was selected, but this caused problems with heat management and, more importantly, severely limited the power potential of the motor. The system run at Le Mans used a new outboard location, but again this was a compromise and the team are currently working on a new iteration of the system to improve the situation. There have been suggestions of moving to a twin-turbo arrangement, partly because packaging two small turbos is easier than housing one large unit, but the engine is still very much in the early stages of its development, and the issues encountered at Le Mans were proof of this. It should be noted, however, that none of the problems were in areas you would expect for a forced

induction motor. In fact, the engine has proved very resilient to high boost pressures and there have been no problems in the area of cylinder or head sealing.

After the first failures, the team identified that the aluminium alternator pulleys had cracked, so a decision was taken to have some steel items produced overnight to cure the problem. Unfortunately, while this stopped the pulleys cracking, it simply moved the problem further down the line, leading to the failure of the drive gear

to the pulley and the early retirement of both cars.

There is no doubting the AMR engine is an innovative approach to the demands of downsized LMP racing, and the team claim it is the lightest Prototype engine available, hinting that this will stand them in good stead for any future developments involving energy recovery systems. Only time will tell if they will be vindicated, but a further year's testing and development should allow the engine to show its true colours. 

## EXTRA DIMENSION

➔ To help deal with the very short development time of the AMR-One, Aston Martin Racing turned to Stratasys for help with 3D printing. The company's Dimension 3D printer was used to mock up the chassis, driver controls and engine of the racecar.

AMR selected the Dimension machine for its rapid prototyping capabilities after seeing the speed and quality of the parts produced for the Prodrive-run rally team in a previous project. Having the machine on site helped the race team to design, test and build a complete car to meet the tight deadline for the 2011 season.

Aston Martin Racing is also exploring the idea of using the 3D printer to make finished

parts to bolt onto the car, and one item currently under consideration is the front splitter. 'When we received final sign off to build the car for this year's ILMC, using rapid prototyping was a no-brainer for us, as we had a tight deadline to meet. Most of the engine was prototyped on the Dimension machine, which also proved very useful for the early stages of determining the driver fit for the car,' explains Aston Martin Racing Team Principal, George Howard-Chappell. 'Without the 3D printer, we would not have been able to test on schedule. Following the success with the AMR-One, we hope to utilise the capabilities of another Stratasys machine to help build and deliver end-use parts for future cars.'

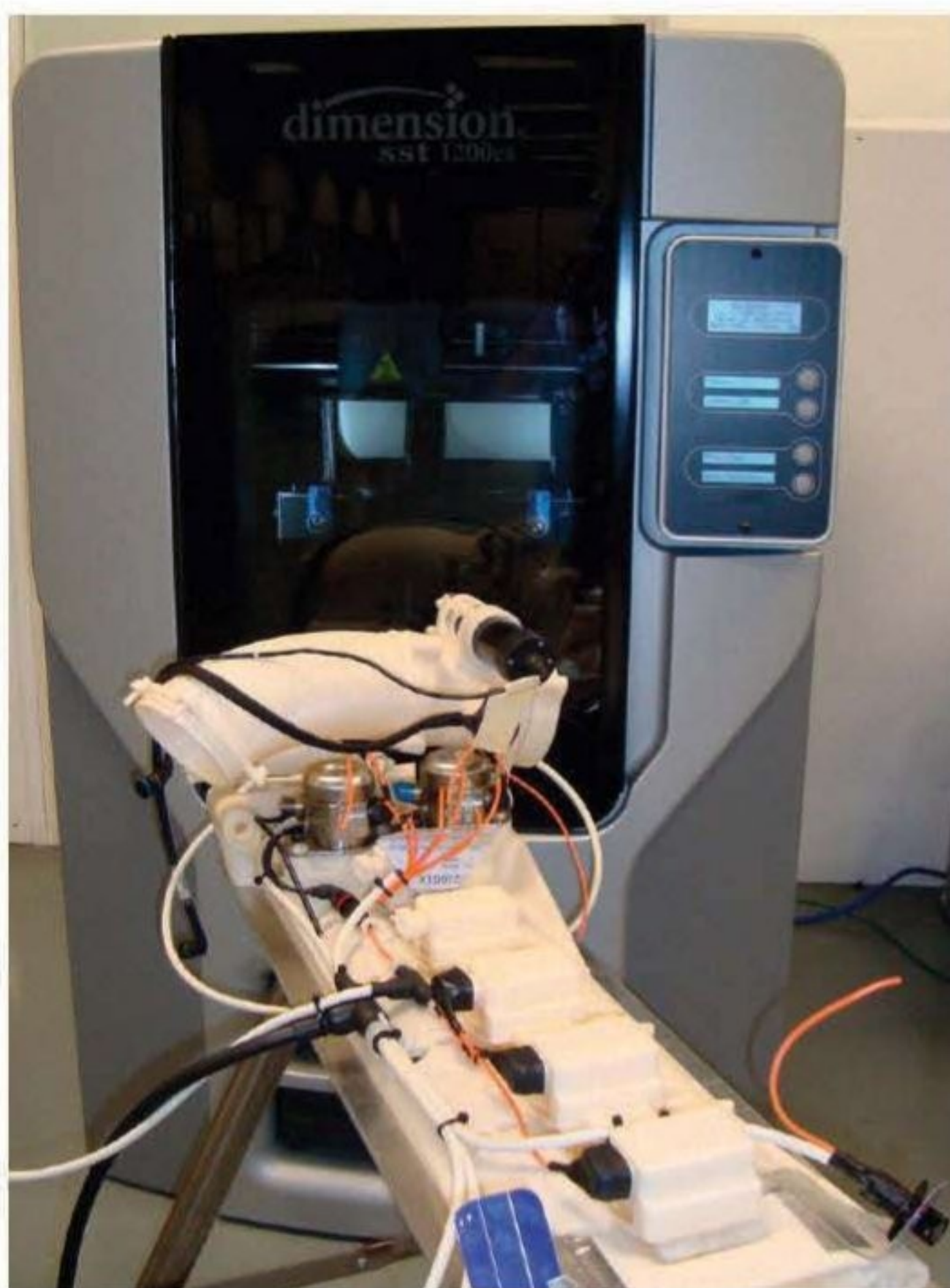

The Stratasys Dimension 3D printer was used to develop chassis, driver controls and engine components. AMR is currently looking into the potential for using the machine to produce finished, race-ready parts



Most of the straight-six engine was rapid prototyped using the Dimension machine, which saved a vast amount of time in the development process



# PMU RACING WINS!

WTCC, BTCC, NASCAR, ALMS, V8SUPERCARS, PORSCHE, DUBAI24HRS, VLN SERIES

In just a short time, PMU Racing brake pads have chalked up an impressive list of victories in most major international categories. Every weekend, more race teams the world over are discovering the PMU Advantage. Whether your racing Sprint, Rally or endurance discover the PMU racing advantage today... before your competition does.



## The **PMU** Advantage

- Unrivalled stopping power
- Outstanding fade resistance
- Industry leading modulation & 'release' characteristics
- Low rotor wear

Carbon Metallic (Sprint) & Sintered Metal (Endurance) compounds available

P.MU Racing, the worlds finest motorsport brake pads are now available through our global distribution network.

Contact your local distributor to experience the P.MU Advantage for yourself.



### GLOBAL DISTRIBUTION CENTRE

Racer Industries +61 7 5591 8198 sales@pmuracing.com  
286 Southport Nerang Road, Southport, Queensland AUSTRALIA



### INTERNATIONAL DISTRIBUTORS LIST:

USA NASCAR/Sportscar	Pro Systems - Mooresville NC - <a href="http://www.prosystembrakes.com">www.prosystembrakes.com</a>
USA West Coast	Mackin Industries - Santa Fe Springs CA - <a href="http://www.mackinindustries.com">www.mackinindustries.com</a>
United Kingdom	Questmead - Lancashire UK - <a href="http://www.questmead.co.uk">www.questmead.co.uk</a>
United Kingdom	Roll Centre Racing - Cambridge UK - <a href="http://www.rollcentre.co.uk">www.rollcentre.co.uk</a>
Germany	Leit Speed - München DE - <a href="http://www.leitspeed.de">www.leitspeed.de</a>
Belgium	Mosa Frein - Namur BE - <a href="http://www.mosa-frein.be">www.mosa-frein.be</a>
Italy	Tecnauto - Milano IT - <a href="http://www.tecnautosrl.com">www.tecnautosrl.com</a>
South Africa	VMP Motorsport CC - Maraisburg SA - <a href="mailto:vmp@iburst.co.za">vmp@iburst.co.za</a>

[www.pmuracing.com](http://www.pmuracing.com)

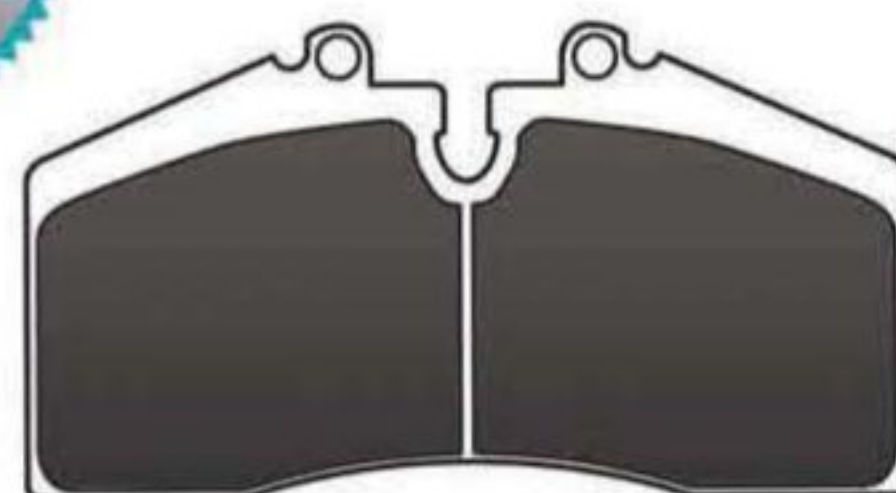

**PMU**  
RACING



# The one in the middle wins races



## DS1.11® & DS2.11®

**SILOXANE TECHNOLOGY**

**BRAKE PADS**



**RACING**

**FEDERAL MOGUL**

The best brands in the business

**Relative Performance Characteristics of  
Ferodo Racing Range Under Heavy-Duty Conditions**

	Pad Life	Disk Life	Average mu	Fade	Pedal Travel	Release
DS 2500	Good	Moderate	Good	Good	Good	Good
DS 3000	Good	Moderate	Good	Good	Good	Good
DS 3000+03	Good	Moderate	Good	Good	Good	Good
DS 3000E	Excellent	Moderate	Good	Good	Good	Good
FER 4003	Good	Moderate	Good	Good	Good	Excellent
DS 1.11	Excellent	Good	Good	Good	Good	Good
DS 2.11	Excellent	Good	Good	Good	Good	Good

Excellent   
Good   
Moderate 

**Race Proven**

- DS1.11 - suffix "W"  
 - A1GP  
 - FIA FT  
 - Touring Cars  
 - Formula Cars  
 - Group N  
 - Stock Cars  
 DS2.11 - suffix "X"  
 - WRC  
 - Rally Group N  
 - Touring Cars



**Circuit Supplies (UK) Ltd**

Unit 8, Eden Court, Eden Way

Leighton Buzzard, Beds LU7 4FY

Tel: 01525 385 888 Fax: 01525 385 898

info@circuitsupplies.com www.circuitsupplies.com





## FIRST PRINCIPLES

**Simon McBeath** offers aerodynamic advisory services under his own brand of SM Aerotechniques - [www.sm-aerotechniques.co.uk](http://www.sm-aerotechniques.co.uk). In these pages he uses data from MIRA to discuss common aerodynamic issues faced by racecar engineers

Produced in association with MIRA Ltd



**Tel:** +44 (0) 2476 355000  
**Email:** [enquiries@mira.co.uk](mailto:enquiries@mira.co.uk)  
**Website:** [www.mira.co.uk](http://www.mira.co.uk)

# It's all in the balance

## More progress on the ADR3 sports racer

**T**his month we continue our studies on the ADR3 twin-seat sports racer, courtesy of constructor, ADR Engineering owner / driver Simon Marsh, and prototype parts makers, Carbon Weezel. The aim of the day-long session spent in MIRA's full-scale wind tunnel was to produce the best downforce possible, together with a front-to-rear downforce balance to match the car's static weight distribution with driver and half fuel load aboard.

Last month's changes added significant front downforce, but the balance was still only 31 per cent on the front axle, whereas

the target was 48 per cent, so subsequent modifications continued to focus on improving the front end.

The car already featured louvred panels over the tops of the front wheelarches, so the next obvious modification was to fit some reasonably large dive planes at a relatively modest angle. Table 1, below, shows the coefficients obtained with the improved splitter and diffuser kit added last month. As usual, the changes are shown in counts, where a coefficient change of 0.100 = 100 counts, and in percentages.

As is often the case with dive

planes, even when they are set at a modest angle, a reasonable balance shift to the front was achieved, albeit not very efficiently. However, 22 counts of total downforce for 17 counts of drag was at least better than 1:1 and, as the car needed more front downforce, 34 counts or 10.8 per cent more front downforce was a useful increment. The balance was now almost 34 per cent at the front.

Next, splitter end plates were added, too. These were in the form of simple carbon sheets taped to the ends of the ramps at the outer ends of the splitter, and the results are shown in table 2, overleaf.

**Table 1: coefficients and changes brought about by fitting dive planes**

	CD	-CL	-CLfront	-CLrear	%front	-L/D
<b>With dive planes</b>	0.603	1.028	0.348	0.680	33.85	1.705
<b>Change, counts</b>	+17	+22	+34	-12	+2.64abs*	-12
<b>Change, %</b>	+2.9%	+2.2%	+10.8%	-1.7%	+8.46%	-0.7%

\* abs = absolute change in % front, not relative percentage change

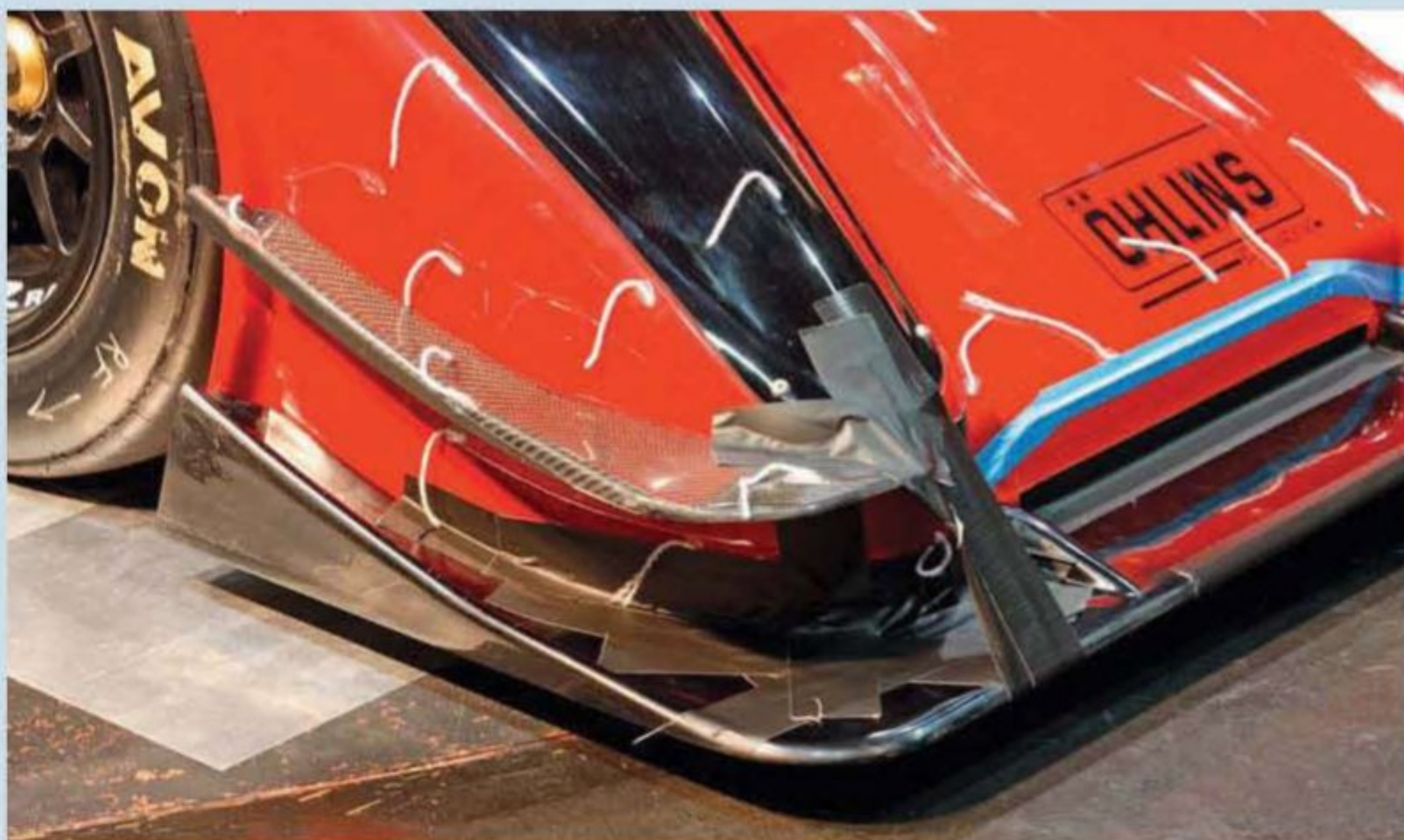

Dive planes added some front downforce, albeit not very efficiently, and knocked a little downforce off the rear

**the wing's interaction with the underbody had improved**

Again, this modification didn't do much for efficiency, though it did reduce drag a little and provided another useful increment of front downforce, so the balance was now approaching 36 per cent at the front.

There then followed a set of configuration changes aimed at improving airflow velocity through the radiators, the constructors being keen to ensure cooling would not be compromised by any other aerodynamic alterations. These involved blanking off various sections of the side openings in the sidepods, and placing fences behind the front wheels. The



**Table 2: the effects of splitter end plates**

	CD	-CL	-CLfront	-CLrear	%front	-L/D
<b>With end plates</b>	0.598	1.022	0.366	0.655	35.81	1.709
<b>Change, counts</b>	-5	-6	+20	-25	+1.96abs	+4
<b>Change, %</b>	-0.8%	-0.6%	+5.7%	-3.7%	+5.79%	+0.2%

**Table 3: coefficients after various cooling system and rear-end modifications**

	CD	-CL	-CLfront	-CLrear	%front	-L/D
<b>New baseline</b>	0.582	1.065	0.360	0.705	33.80	1.830



These front end plates also shifted the balance forwards, but knocked more counts of downforce off the rear than they added to the front. Drag did reduce a little though



This configuration of sidepod produced the best through-radiator velocity, but reduced front downforce somewhat

best of these did indeed improve the radiator flow rate, but at the cost of some front downforce.

A few additional modifications that, it was hoped, would improve drag included removing the rear part of the rear wheelarches and the underslung tail lights, and also removing the engine bay inlet snorkel, which was feeding the whole engine bay rather than just the engine. The coefficients after this part of the session were as shown in table 3, left.

As can be seen, there was a drag reduction relative to the configuration shown in table 2 (16 counts or 5.4 per cent less) and also an increase in downforce, up 43 counts overall (4.2 per cent), but all of this was at the rear. So the balance was back at just under 34 per cent at the front ahead of the next phase, which saw the rear wing location being moved.

**the constructor was keen to ensure cooling would not be compromised**

Initially, the wing was lowered in 33mm increments until it was 100mm lower than standard. It was then moved forwards by 135mm. And finally, the flap angle on the two-element wing was adjusted. The results are shown in table 4, with wing position 1 the same as the previous configuration in table 3.

#### LINEAR REDUCTION

From rear wing position number 1 (stock) to number 4, as the wing was lowered there was a simple trend of reducing drag, and downforce, together with a significant, almost linear reduction in rear downforce, and a concomitant though non-linear increase in the forces felt by the front wheels. With the drag reductions, efficiency also reduced at each step.



# *Brake control from green light to chequered flag.*



Designed and manufactured in Germany,  
proven at classic endurance races across the world.

Pagid RS is the leading brake pad at the Le Mans 24 hour Race and at the Daytona 24 hour 77 % of all starters relied on Pagid RS, including the winning team. Optimal brake performance, perfect friction right from the start, stability at high temperatures and minimum pad and disc wear. Race winners don't ask for anything less.

[www.braketechnology.com](http://www.braketechnology.com) · [info@bremsentechnik.de](mailto:info@bremsentechnik.de)  
+49 6003 82 910

Pagid is a registered trademark of TMD Friction





**Table 4: the results of rear wing location and flap angle changes**

	CD	-CL	-CLfront	-CLrear	%front	-L/D
1. Stock position, flap at mid-position	0.582	1.065	0.360	0.705	33.80	1.830
2. 33mm below stock	0.573	1.041	0.373	0.668	35.83	1.817
3. 66mm below stock	0.566	1.015	0.390	0.625	38.42	1.793
4. 100mm below stock	0.555	0.983	0.400	0.582	40.69	1.771
5. 100mm below + 135mm forward	0.556	1.058	0.437	0.620	41.30	1.903
6. 66mm below + 135mm forward	0.572	1.069	0.429	0.640	40.13	1.869
7. 100mm below + 135mm forward + flap to minimum angle	0.517	0.960	0.466	0.494	48.54	1.857



The stock rear wing position was at the maximum permitted height, often best for maximum downforce



Lowering the wing and moving it forwards by 135mm produced almost as much total downforce but improved both balance and efficiency, leading to the conclusion that its interaction with the underbody had been improved, too

However, when the wing was then moved forwards by 135mm while being retained at this new, 100mm lower height (position 5), total downforce jumped up again to almost the same level it was at before the wing was moved. It also increased by roughly equal amounts at each end of the car, with virtually no change in drag with the forward shift. Efficiency also improved markedly, and balance was now over 41 per cent at the front. The obvious conclusion here was that the wing's interaction with the underbody had improved, hence the roughly equal downforce jumps front and rear with no drag increase.

#### THE SWEET SPOT

The wing was then raised to 66mm below stock height at this new, more forward position (position 6), but the numbers changed for the worse, so position number 5 was elected as the best available. This raised the obvious question about whether position 5 was actually the 'sweet spot' for the rear wing; but with a tight timescale there wasn't the opportunity to explore this further. It did demonstrate the point though that a car with a downforce-generating underbody can sometimes benefit from running the rear wing at lower than maximum height, and with a fore / aft location over the rear body that brings the low-pressure region generated under the wing into more intimate interaction with the underbody diffuser's exit.

Finally, the rear wing flap was adjusted to its minimum available angle (position 7). As expected, this made a pretty big difference to the coefficients and, for the first time, a result reflecting the target balance was obtained, together with a decent efficiency level in the context of this session. We will have more on the ADR 3 next month, including some interesting data on wheelarch louvers. 

*Racecar Engineering's thanks to ADR Engineering, Carbon Weezel and Simon Marsh*



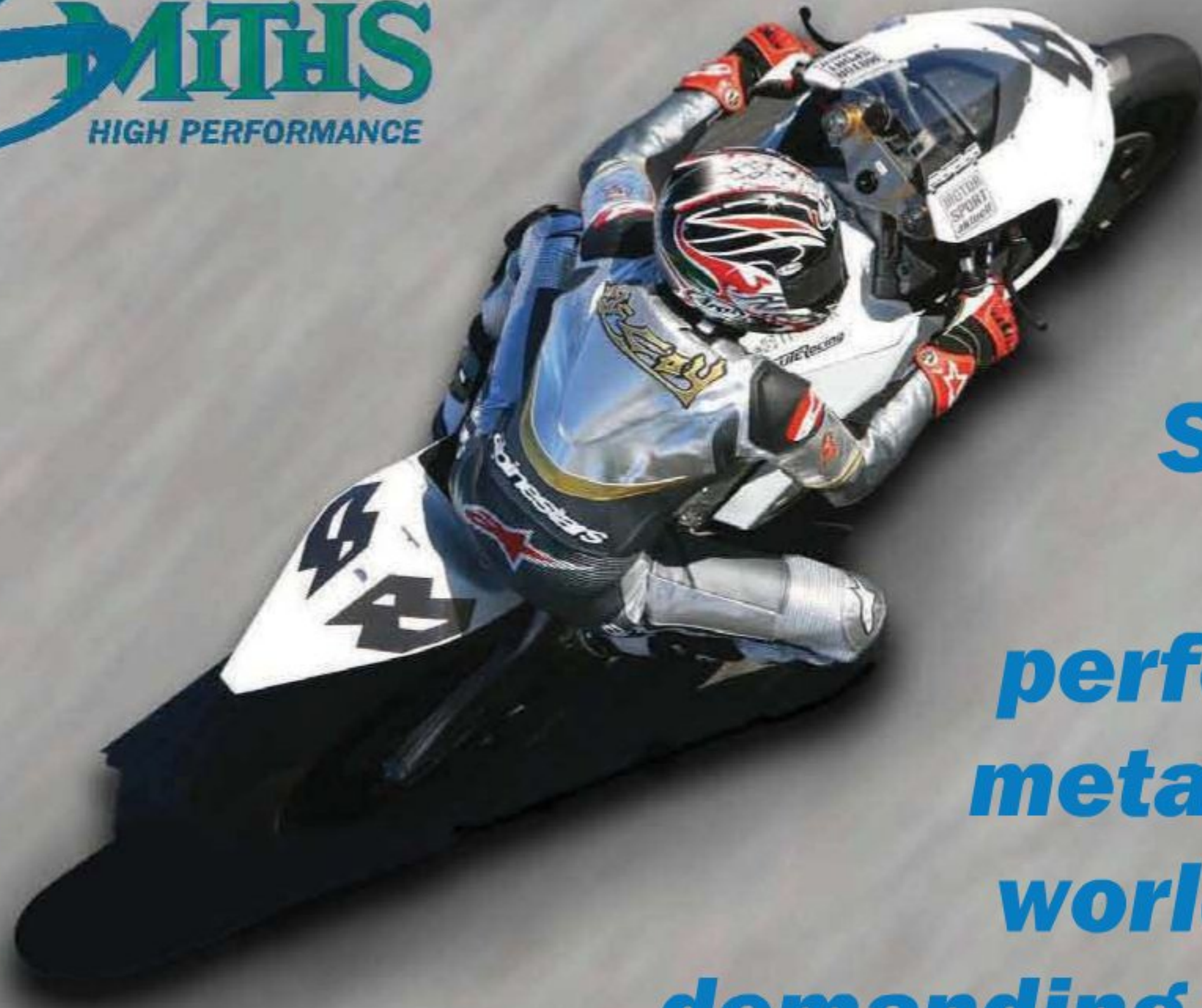

**Stockists  
of high  
performance  
metals to the  
world's most  
demanding markets**

## **ALUMINIUM ALLOYS**

- **7068**
- **7075**
- **4032**
- **2024**
- **2099**
- **2195**
- **2618**
- **2014**
- **Bar, Plate & Forgings**





# VAC ENGINEERED SOLUTIONS



- Complete Engine Builds - Street, Race
- Cylinder Heads - Stages 1, 2, 3
- Oil Systems - Coolers, Pumps
- Dry Sump Kits
- Racing Crank Dampers
- Underdrive Pulley Sets
- Vanos Elimination Kits
- Race Seat Installation Kits

Complete engine machine shop with five CNC machines and in-house Engineering staff.  
Cars across the world have been running VAC Solutions since 1984.

**ONLINE STORE WITH OVER 3,000 PRODUCTS**



WWW.VACMOTORSPORTS.COM

TEL: 215.462.4666

PHILA, PA USA

**Ferrea**  
RACING COMPONENTS

# SUPERIOR

**Craftsmanship and Quality for OVER 45 YEARS!**

## From Sketch to the Race Track...

Our valves are ranked #1 in quality, developed with the latest state of the art technologies that produce superior race proven components. If you need a special custom valve manufactured, whether it's high quality stainless steel or US Spec. Military Titanium grade material, we can manufacture low quantities within 7-10 days.

**Only trust the valves with the Ferrea name.**

Download your QR Reader app to your smartphone to scan our code for more exclusive information.



**LIGHTER | STRONGER | FASTER = MORE POWER**

FOLLOW US ON:

FERREA RACING COMPONENTS

Tech Line: 954-733-2505 • Toll Free: 888-733-2505 • www.ferrea.com



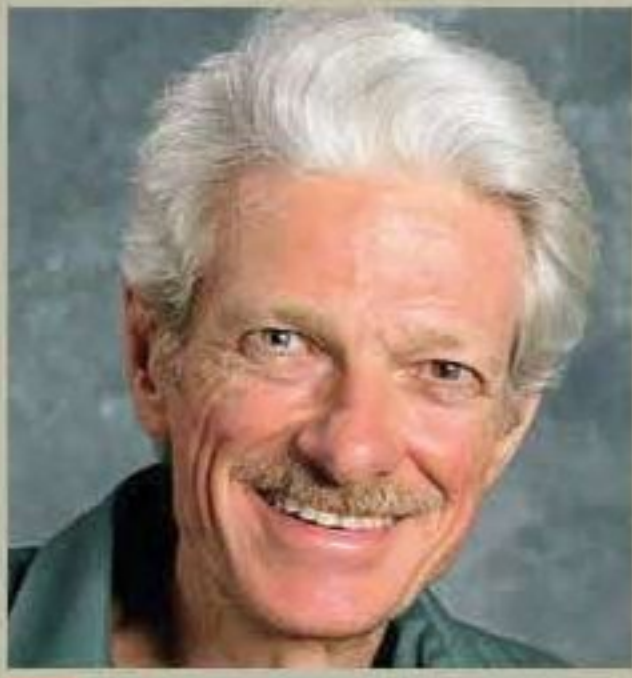

## FIRST PRINCIPLES

Mark Ortiz Automotive is a chassis consulting service primarily serving oval track and road racers. Here Mark answers your chassis set-up and handling queries. If you have a question to put to him

**Email:** markortizauto@windstream.net

**Tel:** +1 704-933-8876

**Write:** Mark Ortiz

155 Wankel Drive, Kannapolis  
NC 28083-8200, USA



## THIS MONTH:

**Q** What effect do anti-roll (sway) bars have on overall performance, and can I remove them completely?

**A** Anti-roll bars allow us to control the suspension in all four modes of motion and allow us to control roll, ride quality and load transfer. You *can* remove them, but it would be unwise on a car that was designed with them

# Why use anti-roll bars?

**Q** In the past you have talked a lot about anti-roll bars and how they affect mechanical traction. My question though is why do we use anti-roll bars (sway bars)

at all? What effect will removing front and rear bars have on the behaviour of the car? Sure, the car will roll on the corners, but what about traction on the bends and overall performance?

I would definitely not advise taking the anti-roll bars, or sway bars in US parlance, off an existing car, and then taking it for a lap at speed, as on most modern cars the front / rear roll stiffness distribution is tuned with the bars, and the car will not have the same oversteer / understeer balance if the bars are removed.

It is quite true that for vehicles with the sprung mass  $c$  of  $g$  heights commonly encountered in cars, roll has only a small effect on overall load transfer. It is also true that we can achieve any roll gradient (how much the car rolls per unit of lateral acceleration) using only the ride springs. And

finally, it is true that we can get *any* front / rear distribution of load transfer using only the ride springs. So why not just do that? After all, many cars have been built with no anti-roll bars, but they basically fall into three categories: ones that roll a lot, ones that ride really hard and don't absorb bumps well and ones with beam axles at both ends.

Anti-roll bars and other interconnective springing devices offer the following advantages; they let us independently control wheel rates in the four modes of suspension motion - roll, pitch, heave and warp. They let us achieve better control of roll for a given ride quality and

they afford us a way to readily adjust front / rear load transfer distribution, with a minimum of effect on other things.

So what's wrong with just letting the car roll? With independent suspension, the wheels inevitably lean with the sprung mass to some degree anyway. We can compensate for this by using geometry that makes camber go toward negative in compression in ride, but we can't get 100 per cent camber recovery in roll without excessive camber change in ride. Generally, we have to accept 50 per cent camber recovery or less. So roll hurts camber, and consequently reduces grip with any independent suspension.



# THE CONSULTANT



According to Ortiz, the last place you would want an anti roll bar is on a Formula Vee, but in Europe they are a common feature, front and rear

Roll also uses up suspension travel and ground clearance and can disrupt the under-car aerodynamics enough to cause problems (these disadvantages occur even with beam axles).

Roll does increase lateral load transfer too, and there is a small lateral migration of the car's c of g with roll, relative to the tyre contact patches. In addition to this, there can be an indirect increase in load transfer if roll forces us to run the car at a greater ride height to avoid the suspension bottoming out.

## TRANSIENT MANOEUVRES

So far, we have only discussed effects of roll in steady-state cornering. In abrupt transient manoeuvres, greater roll displacements imply greater roll velocities and accelerations. Roll acceleration will add to lateral load transfer when the direction of roll acceleration is into the turn. In taller vehicles, this added component of load transfer can sometimes be enough to make the difference between the vehicle staying upright or overturning, which explains why some SUVs, for example, will lift wheels or

roll over in a lane change test, even though they will slide controllably in a skid pad test. Reducing roll displacements in such a vehicle will improve overturning resistance in abrupt manoeuvres.

For road course competition, we want ride stiffnesses and front / rear natural frequency relationships that will make the car ride well and take bumps well, and we need to balance these objectives against a need

**“ we will do well to get between 30 and 60 per cent overall elastic roll resistance from the bars ”**

to keep roll within reasonable limits. For this, we will do well to get between 30 and 60 per cent of the overall elastic roll resistance from the bars, and the rest from the springs.

For a pure racecar, we will generally be more concerned about how low we can run the car without having the underside hit the track (much). We may also need to limit heave

and pitch displacements to control under-car aerodynamics. Those constraints will dictate that we have the car very stiff in the heave and pitch modes, which means adequate roll stiffness will come almost automatically. Even then, however, we will generally run some anti-roll bar to provide fine (and quick) adjustment of roll resistance, including perhaps driver adjustability, and to allow steeply rising ride rate, or

pitch and heave rate, via a third spring.

Big bar / soft spring front-end set ups have long been popular in American Stock Car racing, although this trend is fading. This approach makes sense here as soft springs let the front end compress due to banking and aero forces, while the bar maintains enough roll resistance to keep the car from

being loose. The opposite exists at the rear of a Formula Vee car, where the rules require swing axle suspension, which has an extremely high roll centre and a tendency to jack up in cornering. Here, it works best to use springing that only works in ride, and a wheel rate of zero in roll. The last thing we'd want for this application is an anti-roll bar.

Cars with beam axles at both ends can have ample geometric anti-roll (high roll centres) at both ends, and can consequently have moderate roll gradients without anti-roll bars. Any beam axle suspension without an anti-roll bar has a smaller wheel rate in roll than in ride, because of the springs inevitably being inboard of the wheels. However, high roll centres carry some penalties of their own, even with beam axles, in the form of large lateral movement of the contact patches with respect to the sprung mass on one-wheel bumps. Beam axle suspensions generally perform better without anti-roll bars than independent suspensions do, but there is nothing wrong with using an anti-roll bar with a beam axle either. 



ITS NO SECRET THE GERMANS  
HAVE SOMETHING WE ENVY...  
(Nürburgring)



CONSIDER US EVEN.





# Investing more in technology

Our technology centre is the most advanced in Europe. Extreme engineering and precision other performance cam manufacturers cannot match. Like a negative radius of -35mm, giving the fastest valve opening possible. You might not need such extreme technology but it's nice to know that all our camshafts and ancillaries have been developed by the best to be the best.



**HIGH PERFORMANCE  
ENGINEERING**  
[www.kentcams.com](http://www.kentcams.com)

- Nº1** Kent Cams – the best in Europe:
- No.1 for product development expertise
  - The greatest performance increase of any single modification
  - The widest range of camshaft ancillaries produced on site

- The most advanced technology:  
Negative radius to -35mm  
CBN wheels with constant surface speed  
Multi-angle lobes with CNC dressing  
Marposs 3D C and Z axis position probe  
Microphonic wheel dressing  
Lotus Concept Valve Train software

Cams + Pulleys, Belts & Chains :: Valves & Valve Springs :: Performance Cam Kits & Valve Spring Kits :: Followers & Tappets



## The original CONNECTORS

METICULOUSLY ENGINEERED TO CONNECT

**ADEL WIGGINS** Flexible Tube Connectors  
GROUP

### THE POWER TO SECURE

Stay connected with Adel Wiggins Flexible Tube Connectors! The difference between winning and losing is in the connection. Do not sacrifice a win to a simple hose blowout or burst. This occurs when conventional hose clamps or barbs fail to secure the hose located between the connections or components. Adel Wiggins Flexible Tube Connectors eliminate these failures. This is why so many professional racers today confide in them.

### THE POWER OF EFFICIENCY

Adel Wiggins Flexible Tube Connectors are very efficient when it comes down to valuable time sensitive installation or removal. They can be quickly removed and installed with only one hand, whether they are being used with tubing or hose. The locking latch design eliminates troublesome and time-consuming installation of safety-wire or the necessity of tools to make the connection. The electrical bonding feature eliminates the external clamps, fasteners and jumper wire required in some applications. The W900 series minimizes weight and unit cost, while retaining the proven performance and reliability of other WIG-O-FLEX connectors.

### GET CONNECTED!

Adel Wiggins Flexible Tube Connectors are offered standard in lightweight aluminum and are available in stainless steel or titanium upon special order. They feature an operating temperature range from -120° F to 800° F and are able to withstand boost and pressure levels in excess of 125 PSI.

### CONNECTOR APPLICATIONS:

- Full Engine
- Radiator
- Intercooler
- Oil Cooler
- Turbo & Blower
- Throttle Body



FULL ENGINE  
APPLICATIONS



GET CONNECTED!

**FCP**  
Fluid Control Products, Inc.

Australia: Rocket Industries 02 8825 1900 | England: Goodridge UK 01392 369090 • BMRS 0175 355 3610 • Earls UK 0132 785 8221  
Germany: Goodridge Deutschland 06321 60168 • Krontec 09401 52530 | Italy: Tecnauto SRL 02 738 8773  
Japan: SiFo Corporation 03 5420 4154 | New Zealand: Turbo Vehicles Ltd. 09 525 6696

Toll Free in NA: 800-541-2345

Worldwide: 217-324-3737

[www.fluidcontrol.net](http://www.fluidcontrol.net)



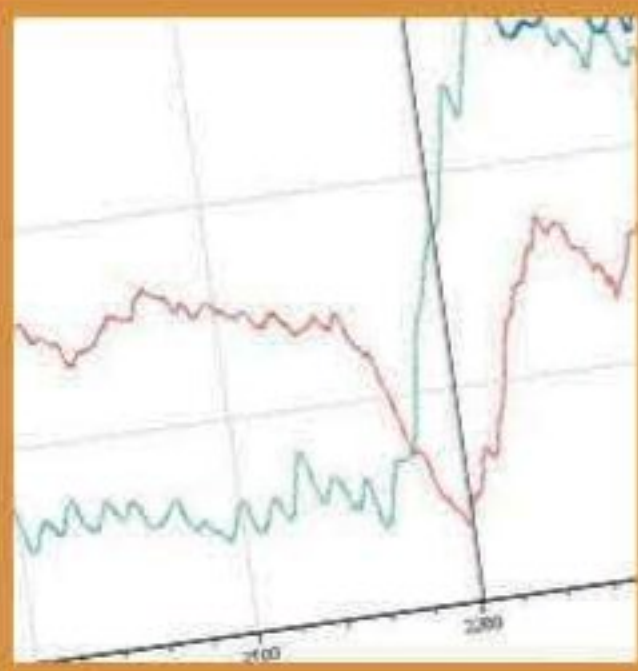

**FIRST PRINCIPLES**

Databytes gives insights to help you improve your data analysis skills each month as Cosworth's electronics engineers share tips and tweaks learned from years of experience with data systems. Plus we test your skills with a teaser each month.

To allow you to view the images at a larger size they can now be found at [www.racecar-engineering.com/databytes](http://www.racecar-engineering.com/databytes)

# A frame of reference

Understanding key comparison factors in a given data outing using common details, such as time or distance

We all know that perspective can change how we interpret what we see. Looking at an aeroplane from a moving car can make it seem almost at standstill, and the sound of an ambulance siren changes depending on whether it's moving towards or away from the listener.

The same applies to the interpretation of racecar data. Different reference points can have a significant effect on how the data is interpreted and whether we can find what we are

looking for. If the correct scale and reference points are not used, it is possible to get false information which in turn can mean a wrong decision in the race.

For example, if an oil pressure alarm comes up, it is necessary to know what the qualifiers for that alarm are. Obviously the pressure itself has dropped below the normal operating value, but the oil pressure is also relative to the engine speed. It may be that the oil pressure warning is of low importance as the engine speed is also very low. Therefore the oil pump might not be at full

capacity. A good way to look at information that changes with another factor is to use an X-Y plot. This clearly highlights when there is a cause for concern.

Below is an oil pressure vs engine speed X-Y plot and it's clear that at high engine speed the oil pressure is normal, but at lower engine speed it drops. This is not a cause for concern. If the oil pressure starts to drop at the far right end of the graph it is time to conduct further investigations.

**TIME OR DISTANCE**

A key element of data analysis programs is the ability to reference not only to distance, but also to time. Producing data relative to distance makes it possible to determine exactly where on the circuit a certain event occurred, and if it's possible to create a basic track map in the software then this becomes even easier to visualise.

Generally when two laps are being compared the reference should be the distance travelled. This makes it possible to see, for example, whether one driver is braking earlier or later than another. Over the page there is an example of the difference between using time and distance for driver comparison.

Looking at the brake pressure it is clear that if the time domain is selected the information seen does not give a correct picture of what actually took place. Using time, it seems that on the green lap the driver applied the brakes earlier than on the red, but switching to distance shows that it is in fact on the red lap that brakes were applied earlier.

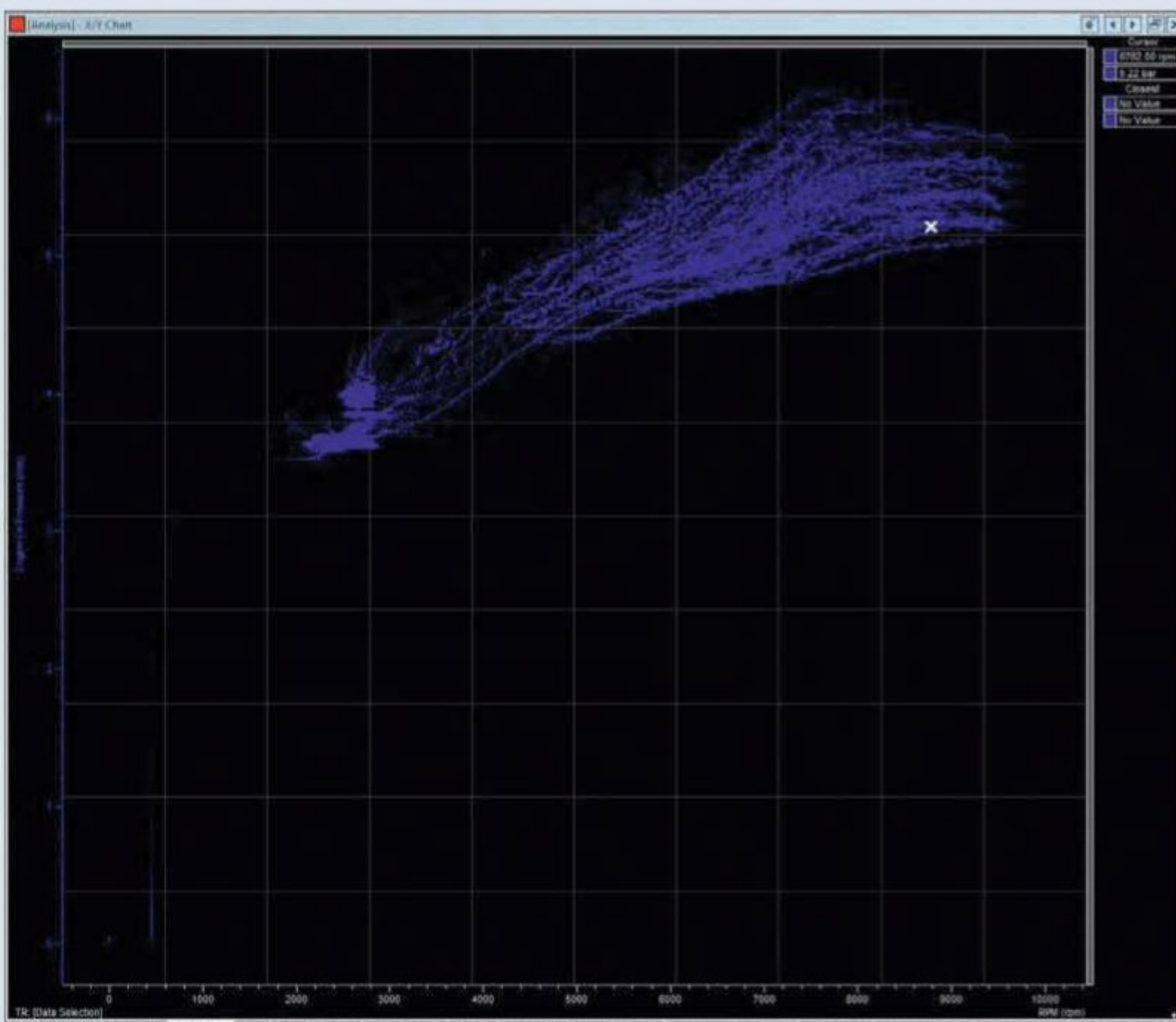
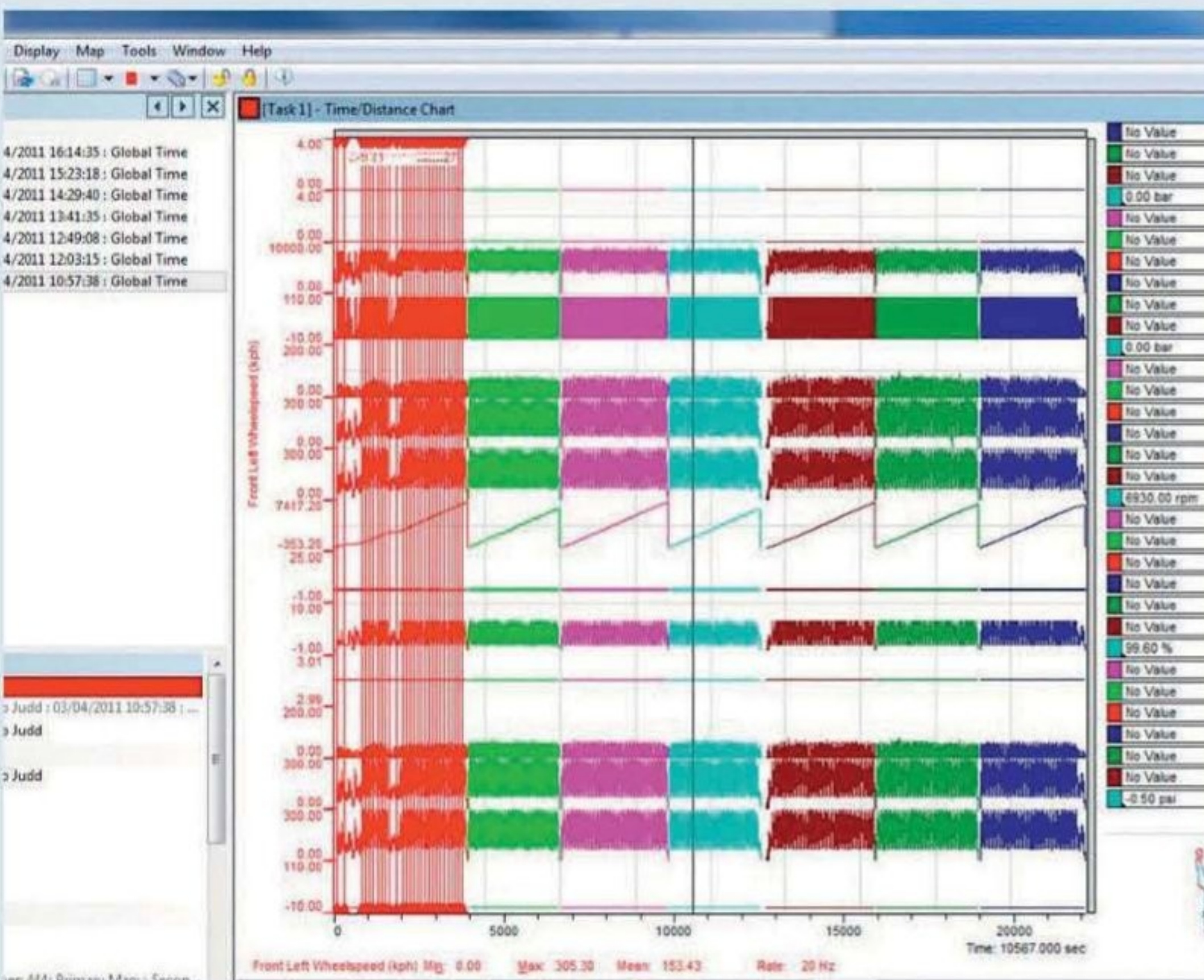

Figure 1 Oil pressure plotted against engine speed





Figure 2 Driver comparison in the time domain (above) and in the distance domain (below)



Outings are organised on a time scale so any trends can be monitored

## TIME IS ALSO RELATIVE

When time is used as a reference point for data analysis, lap time is normally the standard reference, so the time starts when a new lap begins and runs until the start/finish line is crossed again. This is fine for looking at single laps or single outings, but if the intention is to view trends in multiple outings, a different time scale needs to be used. For this the concept of global time can be useful. Global time is the time of day, found either by using the internal clock on the data system or, if possible, by using time from a GPS system. Using global time makes it possible to stack outings based on the time of the day and view trends easily over a long period, and it can be seen whether or not any data is missing. This is especially important in endurance racing as there is a wealth of data gathered, and if something goes wrong with the internal clock of a data system it can be difficult to organise the different outings.

A good example of the use of global time can be seen here, where a number of outings are organised on a time scale so any trends can be monitored. It is also possible to see that at one point between two outings there is an unusually large gap, in this case the car most likely spent some time in the pits before continuing. A further analysis on this gap revealed that there were in fact 172 seconds between the two.

Any good data system will have a number of different options for comparison, scales and reference points. This allows the user to present the data in the most useful format to get the most out of the information gathered. Great care must be taken in making sure that an appropriate frame of reference is used for each case as otherwise it's very easy to miss an important bit of data.

**COSWORTH**

Produced in association with  
**Cosworth**  
 Tel: +44 (0)1954 253600  
 Email: [eenquiries@cosworth.com](mailto:eenquiries@cosworth.com)  
 Website: [www.cosworth.com/motorsport](http://www.cosworth.com/motorsport)





*at the heart  
of the world's  
most powerful  
engines . . .*

## ***Crank and Rod sets from Arrow Precision (made entirely in the UK)***

- Full custom service with reverse engineering facility •*
- FEA analysis, if required •*
- High grade low sulphur CORUS steel, EN40B (722M24) & EN24 (817M40) •*
- Fully machined and accurately heat treated •*
- Fully balanced, both rods and cranks •*
- 100% crack detection •*
- Certification – material, heat treatments, balancing, critical detail report •*
- Stock for popular engines off the shelf •*

*custom to production  
vintage to LeMans  
you need Arrow  
at the heart of  
your engine . .*



***www.arrowprecision.com***

***+44 (0) 1455 294 200***



# Against the odds

How Audi's sole remaining car won Le Mans, using strategy as the ultimate weapon

BY PAUL TRUSWELL



**T**he 2011 24-hour race at Le Mans was probably the closest ever. At the chequered flag, the Audi R18 TDI of Benoît Tréluyer, André Lotterer and Marcel Fässler was just 13.854 seconds ahead of the Peugeot 908 of Simon Pagnaud, Sébastien Bourdais and Pedro Lamy, making this the closest competitive finish since the famous triumph of John Wyer's Ford GT40 in 1969 over the works Porsche 908. Maybe

Peugeot should have changed the nomenclature of its Le Mans contender after all.

What made this race so gripping, though, was that the battle for the lead was close throughout the race (unlike in 1969). For the most part, the gap between first and second could be measured in terms of seconds, or at the outside a minute or two, and at no time did the leader manage to lap the field. Such was the intensity of the race that the lead changed 46 times at the

start / finish line and more than that if you count changes on the track, which didn't get recorded by the timekeepers. Step forward Allan McNish, who briefly took the lead in the number 3 Audi before his violent accident on lap 15.

As a consequence, any attempt to identify a single point at which the race turned will be difficult. The safety car could be the first culprit - it made five appearances in all, for a total of four hours 53 seconds, and inevitably this impacted events

on the track, as drivers tried to stay out as long as possible to avoid being delayed waiting at the end of the pit lane.

Although in the USA pitting during yellow is a way of life, at Le Mans the regulations make it distinctly undesirable to pit while the safety car is circulating. Ultimately, however, fuel needs to be taken and, in the end, each of the leading diesels *had* to stop under yellow flag conditions. The details are in figure 1.

However, even though the

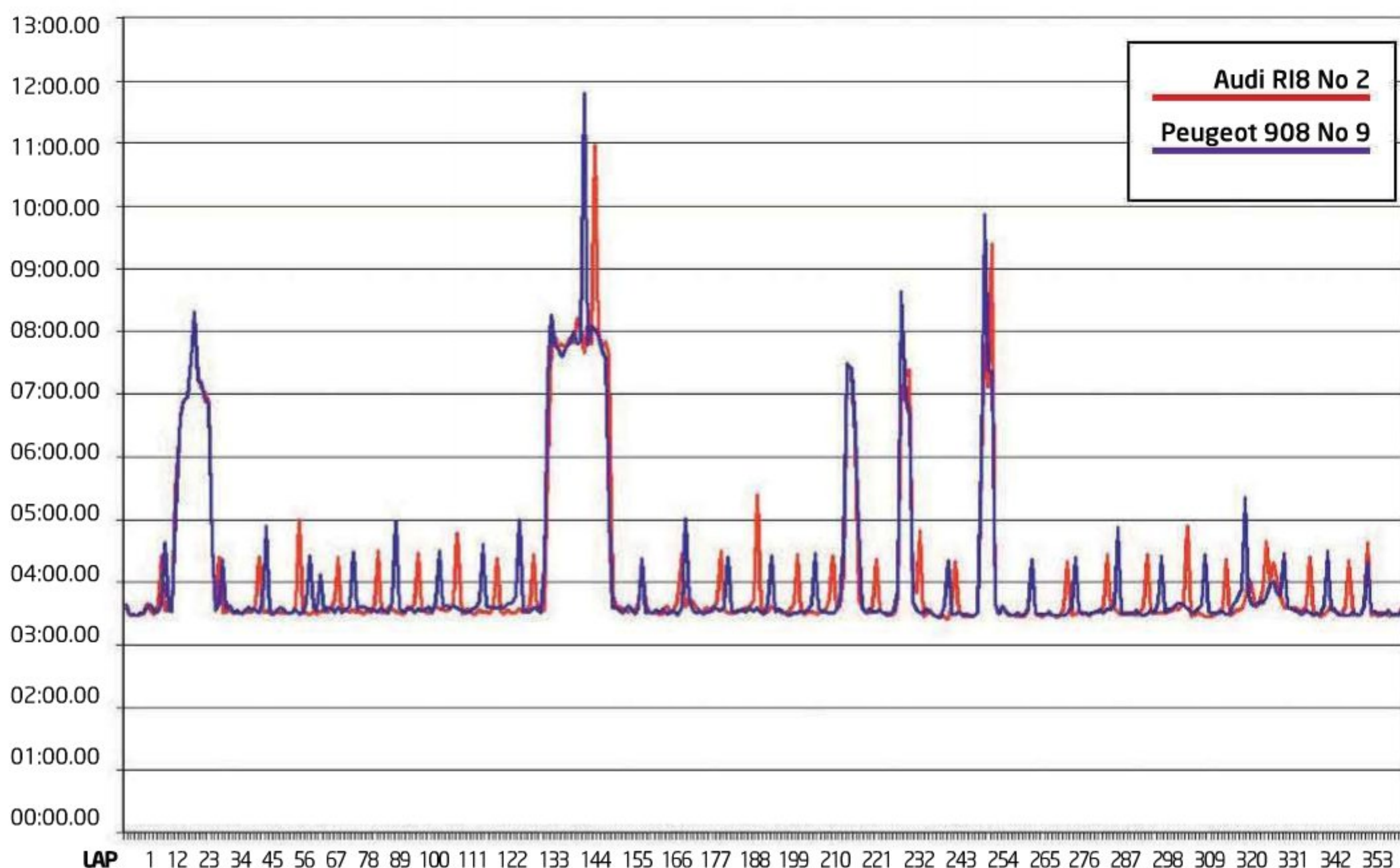



**Figure 1: pit stops during caution periods**

No	Car	Pit stop time	Time of day	Comments
8	Peugeot 908	4m 05.5s	16:46	Driver change, repairs to brake distribution unit
8	Peugeot 908	2m 57.2s	22:43	Fuel only
9	Peugeot 908	3m 57.2s	00:01	Fuel only
7	Peugeot 908	4m 13.5s	00:09	Driver change
2	Audi R18 TDI	3m 11.6s	00:20	Driver change
9	Peugeot 908	1m 56.5s	06:07	Fuel only
2	Audi R18 TDI	2m 17.2s	07:58	Driver change

**Figure 2: Comparison of Lap Times**



The scene was set for an epic battle, with three Audi R18s against three Peugeot 908s. Audi lost two cars before midnight to big accidents; Peugeot remained at full strength throughout

time spent in the pits (the sum of the time spent stationary in front of the garage and the time spent waiting for the pit exit light to go green), varies wildly in this table, the overall effect is the same, since in each case only one safety car has gone past while the affected car is in the pits being worked on. In this case, the overall time lost is more or less one third of a lap, or 70 seconds for an LMP1 car, plus time for each car in the safety car 'train' at the back of which you rejoin.

As can be seen from figure 1, the most fortunate in this regard was Peugeot number 7, which only had to stop once under caution, whereas the other contenders had to stop twice.

**LAP TIMES**

Let's look at the race between the Tréluyer / Lotterer / Fässler Audi and the Bordais / Pagenaud / Lamy Peugeot in more detail. In figure 2 (above), the lap times for each car are shown across the whole of the race. The periods

under full course caution are easy to see. And if you look closely at the period towards the end of the race you can see how the drizzle from about 12:15 (lap 309) on Sunday affected the lap times.

Figure 3 (overleaf) shows the gap between the same two cars over the course of the race, regardless of their positions overall. If the plotted line is above the x-axis then the Audi (no 2) is ahead. If below, then the Peugeot (no 9) is ahead. For clarity, the yellow shaded areas show the safety car periods.

From this, it struck me that the race can be split into three distinct phases:

- Phase 1: from the start until Rockenfeller's accident at 22:40 (lap 117)
- Phase 2: from Rockenfeller's accident (or perhaps better put, from the withdrawal of the safety car following the incident) until about 06:40 Sunday morning (lap 221)
- Phase 3: From 06:40 to the end of the race

**PHASE 1**

Before the race, it had been suggested that what the Peugeot lacked in speed might be compensated by its better fuel economy. If that were to be the case, then it would have to spend less time in the pits. Figure 4





# One Company. One Solution

PMI Europe B.V. is located in The Netherlands and the European hub of Performance Motorsports Inc of the USA which owns the brands shown below. PMI Europe B.V also distributes ARP, Cometic and Carrillo to serve you as a one stop supplier.

New!



Innovate Motorsports Diagnostic equipment (AFR-OBD-II)



K1 Cranks & Rods



ARP Bolts & Studs



Innovate Motorsports



Cometic Gaskets



Wiseco Forged Pistons



Carrillo Rods

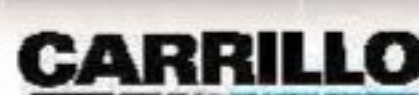

PMI Europe BV  
Pesetaweg 32  
2153 PJ Nieuw Vennep  
The Netherlands

Tel: +31 (0) 252 680437  
Fax: +31 (0) 252 684643  
Email: [info@pmi-europe.nl](mailto:info@pmi-europe.nl)  
Web: [www.pmi-europe.nl](http://www.pmi-europe.nl)



# MAKE THE DIFFERENCE



Make the difference in your Porsche engine project with superior quality of Saenz connecting rods. Tailor made in steel or Titanium, Saenz offers what you are looking for. Not from the shelf, just what you want.



Jacquemin Tuning - 233 avenue de la république - 59110 La Madeleine - France - +33 (3) 20746480 - [www.jacquemintuning.com](http://www.jacquemintuning.com) - [info@jacquemintuning.com](mailto:info@jacquemintuning.com)

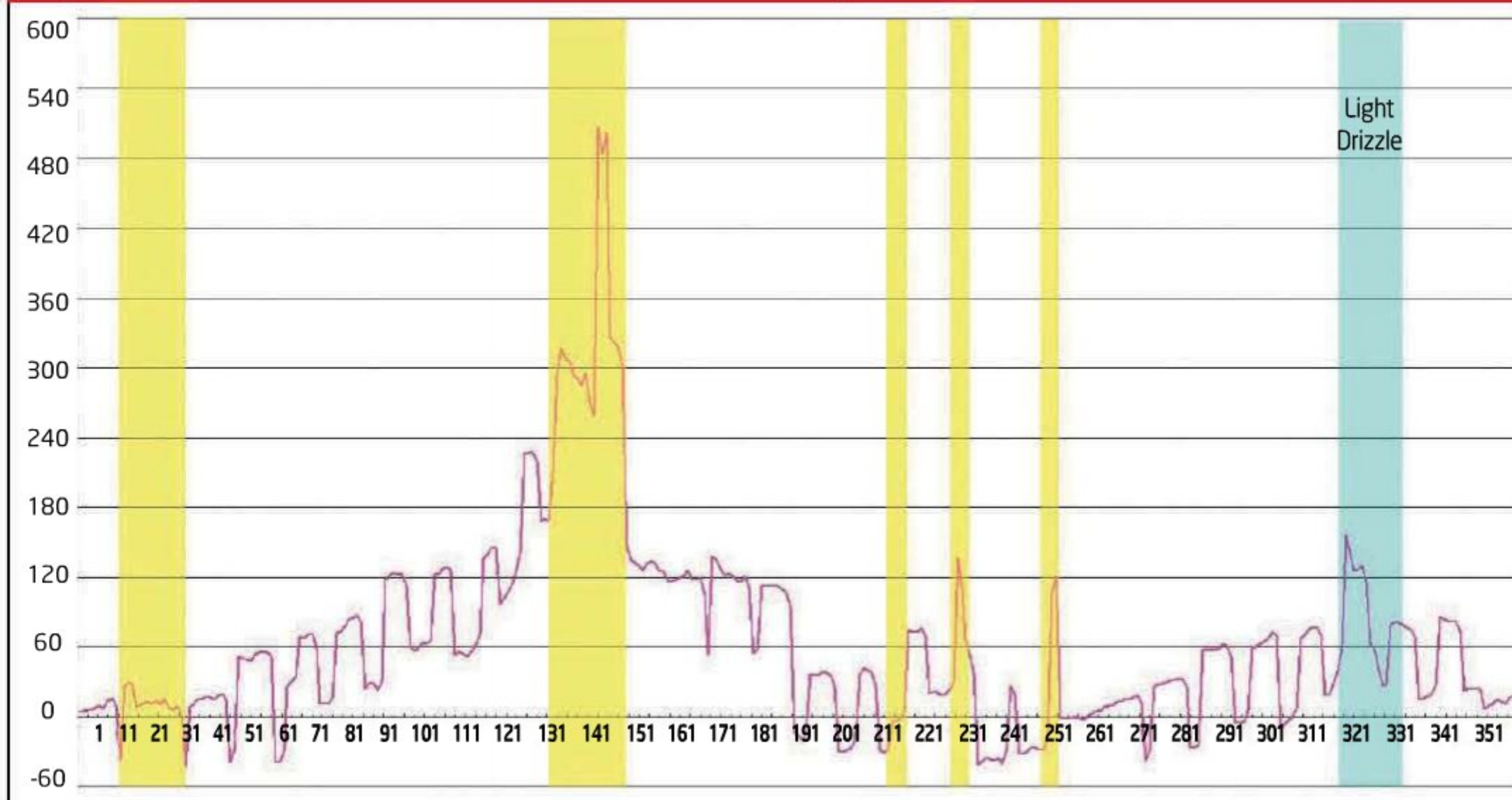

**Figure 3: Gap in seconds from Audi No 2 to Peugeot No 9**

shows the position at the time of Rockenfeller's accident.

By quadruple-stinting the tyres and drivers, Audi's shorter stints (11 laps, compared to Peugeot's 12) and faster pace were paying dividends. Although both Anthony Davidson (in Peugeot no 7) and Stéphane Sarrazin (no 8) also did quadruple stints, the Audis could consistently maintain a better average lap time, as figure 5 shows.

It is also interesting to note from figure 5 how different the drivers' performances were, especially in the Peugeots. I understand, for example, that Peugeot gave Lamy softer tyres for his stint, which he seemed unable to make the most of. It is certainly noticeable how, from 8pm onwards, no Peugeot driver was able to match the average lap times of the drivers from earlier in the race. And in Lamy's case, those 34 laps were the only ones he was to drive in the race - the rest of the driving was done entirely by Bourdais and Pagenaud.

This is probably due to the Peugeot's narrower operating window, as explained in the last issue of *Racecar Engineering*. At the end of Phase One, the Audis were on a charge, capitalising on Peugeot's sudden lack of pace.

#### PHASE 2

The safety cars were out for more than 140 minutes to clear up the mess left by Rockenfeller's crash. When racing resumed, at a little after 1am, the race seemed to turn back towards Peugeot. Firstly, it is worth pointing out

that the French manufacturer did not (yet) try to take advantage of the fact that they had all three of their cars running, all of which were still on the same lap as the leader. A shrewd team manager might have considered deliberately changing the strategy

of one of the team cars, to see if it might gain an advantage on the now singleton Audi.

In fact, Olivier Quesnel and Bruno Famin kept to 'Plan A' - 12 laps per stint, quadruple stints from Sarrazin, Pagenaud and Davidson, but only triples from

**Figure 4: pit stop summary at 22:36 (116 laps)**

Pos	No	Car	Pit stop time	No of stops	Comments
8	2	Audi R18	9m 46.0s	10	Two driver / tyre changes
8	1	Audi R18	10m 08.1s	10	Two driver / tyre changes (replaced nose section)
9	7	Peugeot 908	9m 22.4s	9	Three driver / tyre changes
7	8	Peugeot 908	12m 13.3s	9	Three driver / tyre changes (brake balance issues)
2	9	Peugeot 908	9m 40.7s	9	Three driver / tyre changes

**Figure 5: average lap time analysis, Phase 1**

No	Driver	Car	Average lap time	No of laps	Comments
1	Bernhard	Audi R18	3m 33.1s	16	Two 'green' stints, from 15:00-15:31
1	Dumas	Audi R18	3m 33.5s	44	Four 'green' stints, from 17:36-20:15
1	Rockenfeller	Audi R18	3m 33.0s	39	Four 'green' stints, from 20:16-22:37
2	Tréluyer	Audi R18	3m 31.9s	32	Three 'green' stints, from 15:00 - 18:28
2	Fässler	Audi R18	3m 33.4s	44	Four 'green' stints, from 18:29-21:08
2	Lotterer	Audi R18	3m 32.0s	21	Two 'green' stints, from 21:09-22:25
7	Wurz	Peugeot 908	3m 32.8s	23	Two 'green' stints, from 15:00-17:59
7	Davidson	Peugeot 908	3m 33.4s	48	Four 'green' stints, from 18:00-20:54
7	Gene	Peugeot 908	3m 35.1s	24	Two 'green' stints, from 20:55-22:22
8	Montagny	Peugeot 908	3m 34.8s	10	1 'green' stint, from 15:00-15:35
8	Sarrazin	Peugeot 908	3m 33.4s	36	Three 'green' stints, from 16:50-19:49
8	Minassian	Peugeot 908	3m 35.6s	36	Three 'green' stints, from 19:51-22:02
9	Bourdais	Peugeot 908	3m 33.2s	23	Two 'green' stints, from 15:00-17:55
9	Pagenaud	Peugeot 908	3m 34.5s	36	Three 'green' stints, from 17:57-20:07
9	Lamy	Peugeot 908	3m 35.8s	34	Three 'green' stints, from 20:09-22:13



# "Our objective:

**to consistently satisfy motorsport's demand for the best connection system, bar none."**

- The lightest hose and fitting combination available
- Crimp and reusable hose end options
- Excellent bend radius - less hose used
- All one piece 'billet' fittings, no brazing
- Four exterior braid options
- Custom CNC tube bending service
- Engineering design service - part of your team



## BMRS 2010 Champions in:

NASCAR Sprint Cup • NASCAR Nationwide • NASCAR Truck • NASCAR K&N East  
IndyCar • ALMS LMP • ALMS GT • Grand Am Prototype • Grand Am GT  
World of Outlaw Sprint Car • ARCA • USAR • USAC Midget • ASCS Sprint Car  
Formula Drift • Lucas Oil Dirt Late Model • Knoxville Track • Daytona 24hr  
Daytona 500 • Brickyard 400



www.bmrs.net

USA: BMRS Concord +1 (704) 793 4319  
UK: BMRS Slough +44 (0)1753 545554

# D.A.T.A.S. LTD.

Data Analysis Tools And Simulation

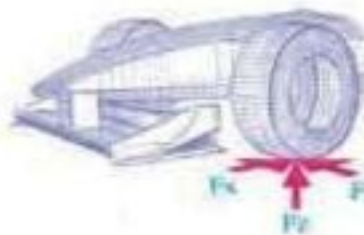

## RaceSim version 2.7

- **Expert:** Steady state, transient, 4 post, optimisation, strategy, etc
- **Standard:** Low cost lap simulation
- **NasCar:** Stock cars with live axle
- **F3 Lite:** Incl. Dallara F3 car model
- **RaceAlyzer:** Race strategy tool - **NEW**
- **ManagePart:** Parts management tool - **NEW**

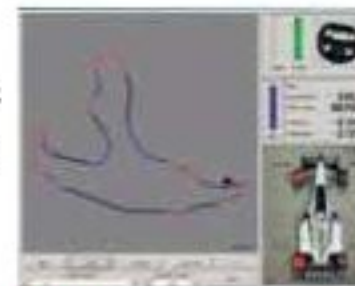

## Consultancy

- Vehicle Dynamics
- Racetrack support
- Software Development

## Multi Media

- Photo realistic virtual animations
- Technical Features for TV
- Animated virtual walk thro' grid



D.A.T.A.S. LTD. THE OLD CHAPEL NORFOLK IP21 4XP

TEL: +44 (0)1603 506526 +44 (0)7802 770345

http://www.datas-ltd.com e-mail: info@datas-ltd.com

ECU/Exchange Loom/Throttle Body Packages available

## Complex modern engine? We can manage it.

ECU solutions for:  
Honda S2000 and K20A  
Ford ST170 and Duratec  
Toyota 2ZZ  
BMW Single / Twin VANOS  
Audi 1.8T and 5 cylinder  
Chevrolet LS7.

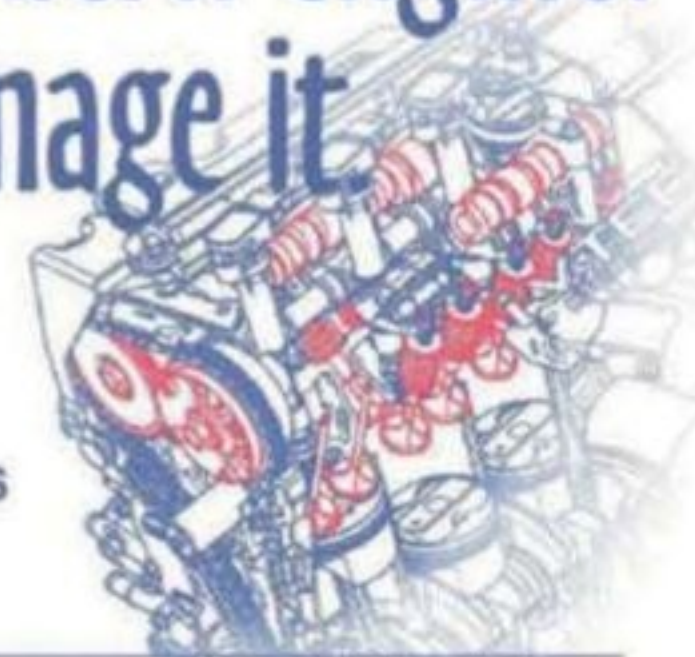

Our ECU's are capable of dealing with the most complex of modern engines without the need to change sensors or sacrifice key features such as variable camshafts.



Get the very best from any engine and from only £495.00 + VAT.

DTAfast, 10 Boston Court, Kansas Ave, Salford M50 2GN  
Tel: +44 (0)161 877 1419 Fax: +44 (0)161 877 7086  
Email: office@dtafast.co.uk Website: www.dtafast.co.uk





The three Peugeot 908s lost time as the temperatures dropped on Saturday night, though they clawed back the deficit

Bourdais, Wurz and Gene. In this context, it is worth emphasising that a pit stop to change drivers and tyres costs an extra 30 seconds over a stop just to refuel. I wonder, if the Wurz / Davidson / Gene car could have run on an '11-lap stint' schedule, how different things may have turned out. It was certainly worth a roll of the dice.

Meanwhile, over in the Audi pits, no one was going home, instead the entire might of the Joest operation turned its attention to the number 2 car.

Possibly as a result of greater caution in the traffic during the night, the Audi average lap time slipped off slightly during the night. Admittedly, it was particularly cold, with air temperature hitting a low of 8degC, and the track temperature dropping below 15degC. Simultaneously, humidity peaked at 80 per cent, making it difficult for anyone to get heat into their tyres. Figure 6 shows how the average lap times compared. With better consumption and better lap times, plus the impact of further safety car periods at the end of this phase, the Peugeots were closing in on the Audi.

### PHASE 3

As the sun came up and visibility improved, conditions were ideal for setting fast times. At 06:44, on lap 222, André Lotterer in

the no 3 Audi set a new fastest lap of 3m 27.710, eclipsing by three-thousandths of a second the best lap set by Anthony Davidson in the dead of night. Four laps later, Sebastien Bourdais in the Peugeot - now leading the race - set a 3m 27.388 but, on his very next time through, Lotterer went better still at 3m 26.298. On his next lap, Bourdais matched this time, to the thousandth of a second! Lotterer still had four laps of fuel in his tank, and on his 229th lap, at 7:08am, he set what was to stand as the fastest lap of the race at 3m 25.289s.

At this point, as the graph

in figure 3 shows, the Peugeot was spending more of its time leading the race than it was in second place, but the final safety car period (between 7:37am and 8:07am) closed things right up. With the safety cars on the circuit, and André Lotterer running out of fuel, Audi had to make a pit stop. Benoît Tréluyer then set off as the clock struck 8am, on what was to be a quintuple stint. Figure 7 shows the average lap times during this shift.

Meanwhile, things started to go wrong for Peugeot. Just before 9am, Peugeot no 8 was given a one-minute stop-and-go penalty

because one of the mechanics had not been wearing protective goggles during a pit stop. This car had already dropped a lap behind, but this would put it right out of contention.

Then, at 9:48am, Alex Wurz made a mistake at Indianapolis and went off into the gravel, damaging the front of the car. He managed to make it back to the pits but, by the time repairs had been made, some four laps had been lost. Now it was all down to the number 9 car. During the previous caution period, the team had taken advantage of the safety cars to change the radio

**Figure 6: average lap time analysis, Phase 2 (from 01:05-06:15)**

No	Driver	Car	Average lap time	No of laps	Comments
2	Tréluyer	Audi R18	3m 34.7s	32	Three 'green' stints, from 01:32-03:28
2	Fässler	Audi R18	3m 33.3s	21	Two 'green' stints, from 03:30-04:46
7	Wurz	Peugeot 908	3m 33.9s	24	Two 'green' stints, from 01:34-03:01
7	Davidson	Peugeot 908	3m 32.3s	35	Three 'green' stints, from 03:02-06:06
8	Sarrazin	Peugeot 908	3m 33.8s	36	Four 'green' stints, from 01:14-04:07
9	Bourdais	Peugeot 908	3m 31.7s	12	One 'green' stint, from 01:34-02:17
9	Pagenaud	Peugeot 908	3m 33.1s	36	Three 'green' stints, from 02:18-:28

**Figure 7: Tréluyer's quintuple stint (from 08:00-11:17)**

Lap at start	Start time	End time	Average lap time	No of laps	Comments
240	08:00:40	08:42:58	3m 50.7s	11	Safety car out until 08:07 (two laps)
251	08:43:50	09:18:38	3m 28.8s	10	Fastest stint of race
261	09:19:29	09:58:07	3m 30.7s	11	
272	09:59:00	10:37:51	3m 31.9s	11	
283	10:38:45	11:17:48	3m 33.0s	11	



# LE MANS 2011 RACE ANALYSIS

on the car while it was in the pit. As has already been explained, no extra time was lost doing this, but Pagenaud could simply not match Tréluyer's times on the track. Worse, the Peugeot was back to triple stints, from 07:45 to 10:09 with Pagenaud and from 10:10 to 12:17 with Bourdais.

At 11:17 Tréluyer came in

and handed over to Lotterer, Audi deciding that the German had slightly more pace than Fässler, who was due to drive next. The plan was for Lotterer to drive to the flag, if possible, meaning a monster stint of three hours and 43 minutes. For Peugeot, Simon Pagenaud would drive the final stint, getting into the car at 12:18,

with no prospect of new tyres.

By now, the Audi could preserve its lead through the pit-stop sequence and, provided all other things remained equal, it looked as though things were beginning to fall in Audi's favour. However, the skies were darkening and at around 12:15 it started to rain. Figure 8 shows the

details of the lap times of Lotterer and Pagenaud as the track became wetter, dried slightly and then became wetter again. Now, if you subtract the time spent in the pits for both cars from the total of the lap times for the 16 laps, then Pagenaud's average is 3m 45.1, compared to Lotterer's 3m 47.5. And both cars were on slicks, remember. (Only Gene, in Peugeot no 7, went onto cut Michelin slick tyres.)

By 13:30, the rain had stopped, and the leading cars were separated by just 15 seconds, with the Audi ahead. Both cars would have to make two more stops for fuel, but whereas the Peugeot would need two full tanks to get to the finish, the Audi would be able to get away with a 'splash and dash' final stop. Audi also had the flexibility to decide when to make that stop.

As they started their 344th lap, Lotterer was 24 seconds ahead of Pagenaud. The Audi needed around 15 seconds of fuel, the Peugeot about twice as much. Sensibly, Audi decided to come in for fuel at the earliest opportunity, and Lotterer headed up the pit lane at 60kph at 14:22. Pagenaud followed the Audi into the pits, refuelled, and as he set off up the pit lane, saw the Audi coming down off the jacks having had the tyres changed! As they crossed the timing beam at pit out, the gap was 7.8 seconds, marginally less (perhaps) than Audi had calculated (see fig 9), but enough. From here on in, nothing could stop Lotterer - he had fresh tyres, a clear road ahead and sportscar racing's biggest prize waiting for him.

Except that the road ahead wasn't quite clear. Marc Gene, in the no 7 Peugeot, four laps behind, still needed to be lapped. An hour and a half earlier, Gene had proved particularly difficult for Lotterer to pass, and there was head shaking in the Audi garage and Gallic shrugs chez Peugeot. It was the last hurdle for Lotterer, though he was on fresh tyres and was battling for the biggest prize in endurance motor sport. Deep breaths were taken and Lotterer squeezed through, reeling off the final six laps to take a memorable victory. 

**Figure 8: lap times during period of light rain**

Lap	Time	Audi No 2	Peugeot No 9	Comments
310	12:16	03:33.544	03:53.463	No 9 pits
311	12:19	03:43.438	03:53.463	No 9 time includes pit stop - driver / tyres
312	12:23	04:03.202	03:47.045	
313	12:27	03:52.737	03:37.656	
314	12:31	03:35.863	03:37.084	
315	12:35	03:38.724	03:42.015	
316	12:38	03:53.390	03:39.217	No 2 pits
317	12:43	04:38.661	03:45.164	No 2 time, includes refuelling pit stop
318	12:47	04:02.382	03:56.897	
319	12:51	04:18.580	04:01.811	
320	12:56	04:03.231	03:49.261	
321	12:59	03:46.694	03:47.533	No 9 pits
322	13:03	03:35.641	04:27.576	No 9 time, includes refuelling pit stop
323	13:06	03:34.975	03:37.767	
324	13:10	03:35.219	03:34.419	
325	13:14	03:35.194	03:32.829	

**Figure 9: Audi's final pit stop calculation**

- We need: 15 seconds for fuel - take on 20 seconds for safety.
- Peugeot needs: 28 seconds for fuel
- We can change tyres in 24 seconds
- Our projected pit stop time: 20 + 24 = 44 seconds
- Peugeot projected pit stop time: 28 seconds
- Our current lead: 24 seconds.
- Projected lead after pit stop: 24 - (44-28) = eight seconds!

**Pit work and strategy were key in deciding the outcome of the race. Audi played the tactical game to perfection, while Peugeot failed to split the strategy between its three cars**







**Call us first...**



Unit 31 Silverstone Circuit Towcester Northants NN12 8TN  
T: 01327 857822 F: 01327 858096 [www.tridentracing.co.uk](http://www.tridentracing.co.uk)

# SG9M Cylinder Head Seat & Guide Machine



# ROTTLER

## THE CUTTING EDGE

### Unipilot<sup>®</sup> ROTTLER TOOLING

*The speed of live and  
the accuracy of fixed*

**Rottler  
Open House 2011**

September 30 & October 1  
Visit [www.rottermfg.com/open\\_house.php](http://www.rottermfg.com/open_house.php)  
for details & registration

**Control  
depth, finish &  
concentricity  
in one single  
step!**

**New High  
Speed Spindle  
40-1000RPM**

Visit our Web Sites at [www.rottermfg.com](http://www.rottermfg.com) • [www.youtube.com/rottermfg](http://www.youtube.com/rottermfg)

8029 South 200th St. • Kent, Washington 98032 USA  
email: [contact@rottermfg.com](mailto:contact@rottermfg.com)

**Tel: +1-253-872-7050 • 1-800-452-0534**



# At last - TPMS without the "dreaded" batteries!!!

Stack's unique Tyre Pressure and Temperature Monitoring System (TPMS) has eliminated the electronics and batteries from the sensors, providing new limits of performance for TPMS, and significantly increasing sensor life to 5 seasons or more! We've reduced the first year cost, and eliminated on-going maintenance costs.

- Less weight – only 10g (0.35oz).
- Sampling rates up to 10Hz without reducing sensor life.
- Auto-detect wheel changes without pre-programming.
- Maintenance free - longer life, significantly lower running costs.
- Higher continuous operating temp – up to 150°C (300°F) or above.
- CAN output for connection to existing systems.
- Measures both pressures and temperatures.
- Specialist high sampling rates – up to 40Hz.



To find out more call +44 (0)1869 240404 or visit [www.stackltd.com](http://www.stackltd.com)

Smart phone users can scan this code for more information from our website.



**STACK  
STACK  
STACK**

*...when only the best will do!*

Contact: Gordon Riseley  
email: [griseley@ringspann.co.uk](mailto:griseley@ringspann.co.uk)



High Performance

Motorsport

Gearshift & Throttle Cables



**RCS**

[www.RCScables.com](http://www.RCScables.com)  
Tel 01234 342511

**RCS - Cables and Controls**

**OWEN DEVELOPMENTS**



MOTORSPORT TURBO'S & ENGINE CONTROL



**MINI  
CHALLENGE**



FIA FORMULA TWO CHAMPIONSHIP

Life Racing



**Garrett**  
Motorsport Turbochargers

**MITSUBISHI**  
Performance Turbochargers

**TIAL** TURBONETICS  
SPORT

++44 (0)1865 821062

[WWW.OWENDEVELOPMENTS.CO.UK](http://WWW.OWENDEVELOPMENTS.CO.UK)



# Peugeot's great adventure

To go further on a tank of fuel the French team shed a lot of drag from its 908's

It was a great adventure. All the ingredients for a classic race were there and the race did not disappoint in that respect. We are not happy with the result, of course, because we came here to win. Our rivals undoubtedly had a bit more performance, but we had other qualities. The race went away from us due to two or three details,' explained Bruno Famin, Peugeot Sport's Technical Director. Peugeot had adopted a very different approach to Le Mans compared to Audi.

The Paris-based marque set its 908's up in very low drag trim, meaning that the car burned less diesel than its rival and could run an extra lap per fuel stint.

To achieve this the 908's had a number of changes compared to the cars run on the official test day in April. Amongst them was a new rear wing which follows the same principles as the Oak racing 'blobby' wing featured last month. Instead of using raised 'blobs' along the wing's upper surface there is a groove just ahead of the trailing edge which essentially serves the same



**Spot the difference.** At test day the 908's sported sidepod louvres a conventional rear wing and a different engine cover (top). Peugeot did not run its low drag body until race week (above).



**Left:** The rear wing used on all three 908s at Le Mans feature a dip just ahead of the mandatory 20mm wicker. This goes some way to negating the drag it creates for a minimal loss in downforce





The low drag nose used by Peugeot at Le Mans and Spa has less cooling compared with the original. The brake ducts have been relocated to NACA ducts in the centre of the front panel. The high downforce nose used at Sebring (above) has much larger radiator ducts and large brake ducts.

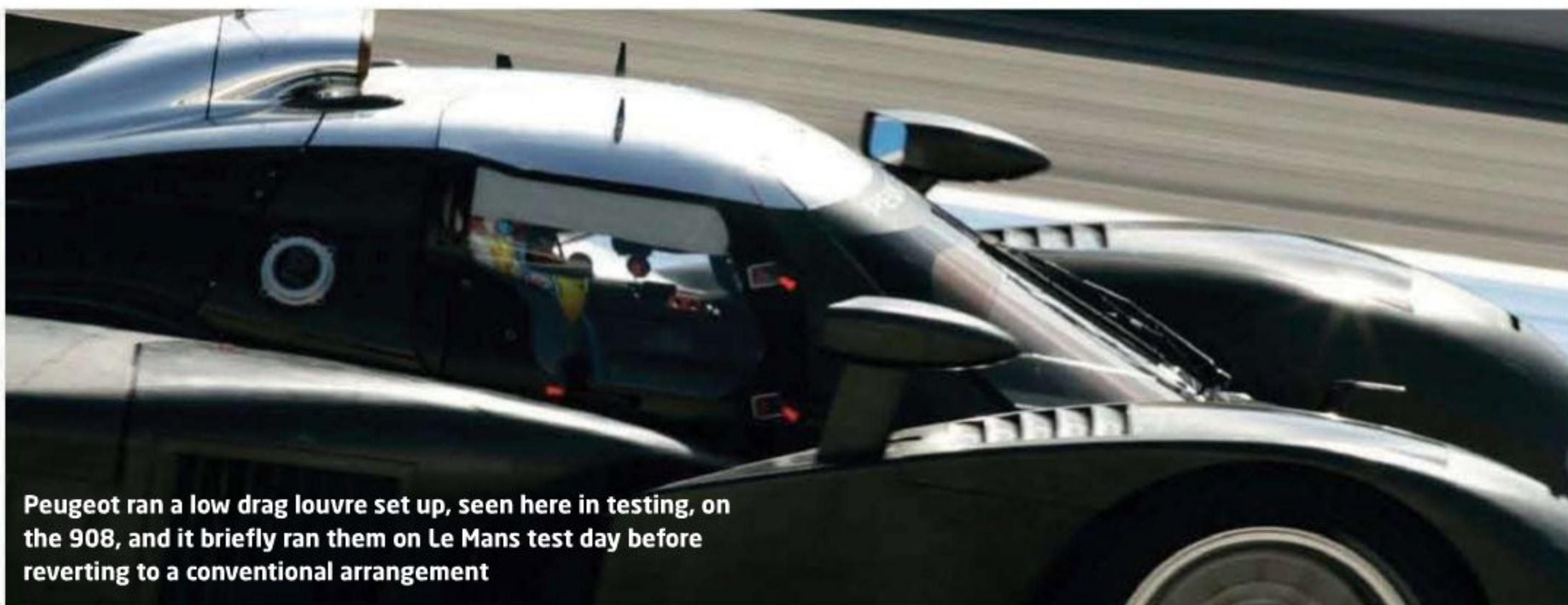

Peugeot ran a low drag louvre set up, seen here in testing, on the 908, and it briefly ran them on Le Mans test day before reverting to a conventional arrangement

purpose. This means that the mandatory 20mm wicker's drag inducing influence is reduced.

Other low drag features included running the sidepod louvres fully blanked off (see pictures) and a revised engine cover. A low drag nose was introduced at the Spa 1000km replacing the high cooling/high downforce nose run at Sebring.

The low drag setup did indeed see the 908 burn a lot less fuel than its rival as well as a higher top speed, cutting the beam at 342kph on the approach to the first chicane compared to Audi's 334kph at the same point on the track. However, the 908 did seem to suffer from the Achilles heel mentioned in last month's *Racecar Engineering*, namely a narrow operating window. Its setup is critical, and as night fell at Le Mans the temperature dropped and the 908's lap times rose. This is where Audi made back its first pit stop and began to put a gap on Peugeot. Peugeot's fuel-efficient low drag, low downforce approach ultimately cost them the race albeit by a narrow margin; as the temperature fell the 908's simply did not have the pace of the R18. Interestingly, the noise level of the 908 was equal to that of a GT Porsche whilst the R18 was quiet as ever. Perhaps the Audi engineers do not have to push the V6 mono turbo as hard to get the same power? 



# Bosch, turning all corners into the home stretch

125 Years  Bosch  
1886-2011



**Safely across the finish line:** ABS M4 from Bosch prevents wheel lock-up while maintaining controlled slip. All possible thanks to easily adjustable control settings specifically designed with competition in mind. This is where our experience lies – Bosch was the world's first automotive components supplier to launch ABS in to mass production in 1978. [www.bosch-motorsport.com/abs](http://www.bosch-motorsport.com/abs)



**BOSCH**  
Invented for life

young  
calibration

**TEST AND CALIBRATION SERVICES FOR THE HIGH-PERFORMANCE MOTORSPORT INDUSTRY**

- > Calorimetric Heat Exchanger Performance Testing
- > Radiator, Oil, Transmission and KERs' Coolers
- > Core Cleaning Services
- > Instrumentation Calibration Services

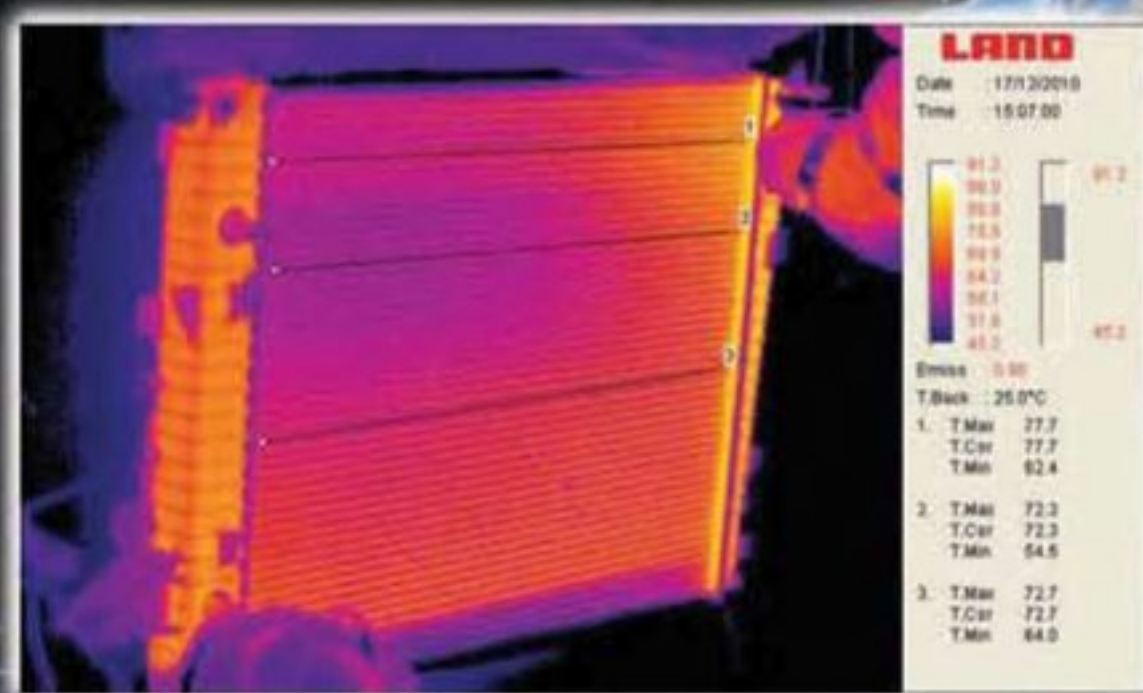

UNIT 4, HAM BUSINESS CENTRE, BRIGHTON ROAD,  
SHOREHAM BY SEA, WEST SUSSEX, BN43 6RE  
Tel: +44 (0)1273 455572

[www.youngcalibration.co.uk](http://www.youngcalibration.co.uk)



# Project 56

How Ben Bowlby's DeltaWing IndyCar concept has translated into a Le Mans Prototype



Immense pressure forms precious stones and, in the case of DeltaWing designer Ben Bowlby, relentless pressure and scrutiny of his radical open-wheel racer has produced a rare gem that's destined for La Sarthe in 2012.

After steeling himself against the steady din of 'it won't turn' and 'it will never work' that came when the DeltaWing IndyCar project was revealed early in 2010, Bowlby quickly moved on to find a new application for his low-weight, low-drag concept, once the open-wheel sanctioning body passed on his creation for the new 2012 IndyCar.

The roots of Bowlby's design were sound - 425kg, 300bhp and an unparalleled L/D ratio - but, with the door closed on open-wheel racing for the immediate future, adjustments would be required for the car to compete in the real world.

While the sight of 33 identical DeltaWings racing at Indy did not appeal to those in charge

## BY MARSHALL PRUETT

of the American series, the Automobile Club de l'Ouest (ACO) saw immediate value in the car as a recipient of its invitational 'Garage 56' entry for the 2012 24 hours of Le Mans. With the addition of a second seat, the DeltaWing had gone from Indy to LMP overnight.

Bowlby: 'The ACO said, 'Wow, we've been worried about how to take 100kg out of the car and you're halving the weight. That's fantastic. This is the sort of project that we would like to see in the 56th garage.' Then after much to-ing and fro-ing with correspondence and understanding what they needed, we received a communication from the ACO requesting submissions for vehicles that could compete outside the classifications and without necessarily complying with the regulations, other than obvious safety and competition and rules and so on.'

## FROM DIGITAL TO REALITY

With the green light from the ACO at the Long Beach Grand Prix in April, assembling the final team to transport the DeltaWing from the digital domain into reality became the most urgent priority. As the 'Project 56' programme gained momentum, interest began to build from some of North America's most influential road racing constituents. ALMS founder, Don Panoz, joined as an advisor, and also lent his REAMS (Recyclable Energy Absorbing Matrix System) technology to the programme. Dan Gurney, legendary driver and owner of All American Racers, agreed to build the car, and one other major party - one that has so far chosen to remain in the shadows - has served as a financial contributor.

The final element of the team came in the form of Duncan Dayton and his back-to-back ALMS LMP championship-winning Highcroft Racing concern, which will develop and campaign the car.

So, with a British designer

and race team and a stars-and-stripes contingent supporting and fielding the effort, production is expected to begin late summer, with the first track test planned for November.

'From the technical standpoint,' Bowlby continued, 'the two-seater LMP1 tub is almost a drop-in fit to the DeltaWing concept. The 30 inch wide bodywork in the front of the car is about the width of a two-seat FIA cockpit. We've got the engine and gearbox in the same place and it's based around, if you like, a completely conventional LMP1 tub. It's just the driver's positioning in the car is much more rearwards than a standard LMP1 car - as it has been in the DeltaWing concept all along - to ensure their weight distribution is correctly observed.'

'Going from a single-seater chassis to a two seater will add about 10 per cent (45kg) to the car's weight, but this is the most significant addition of weight we'll face.'



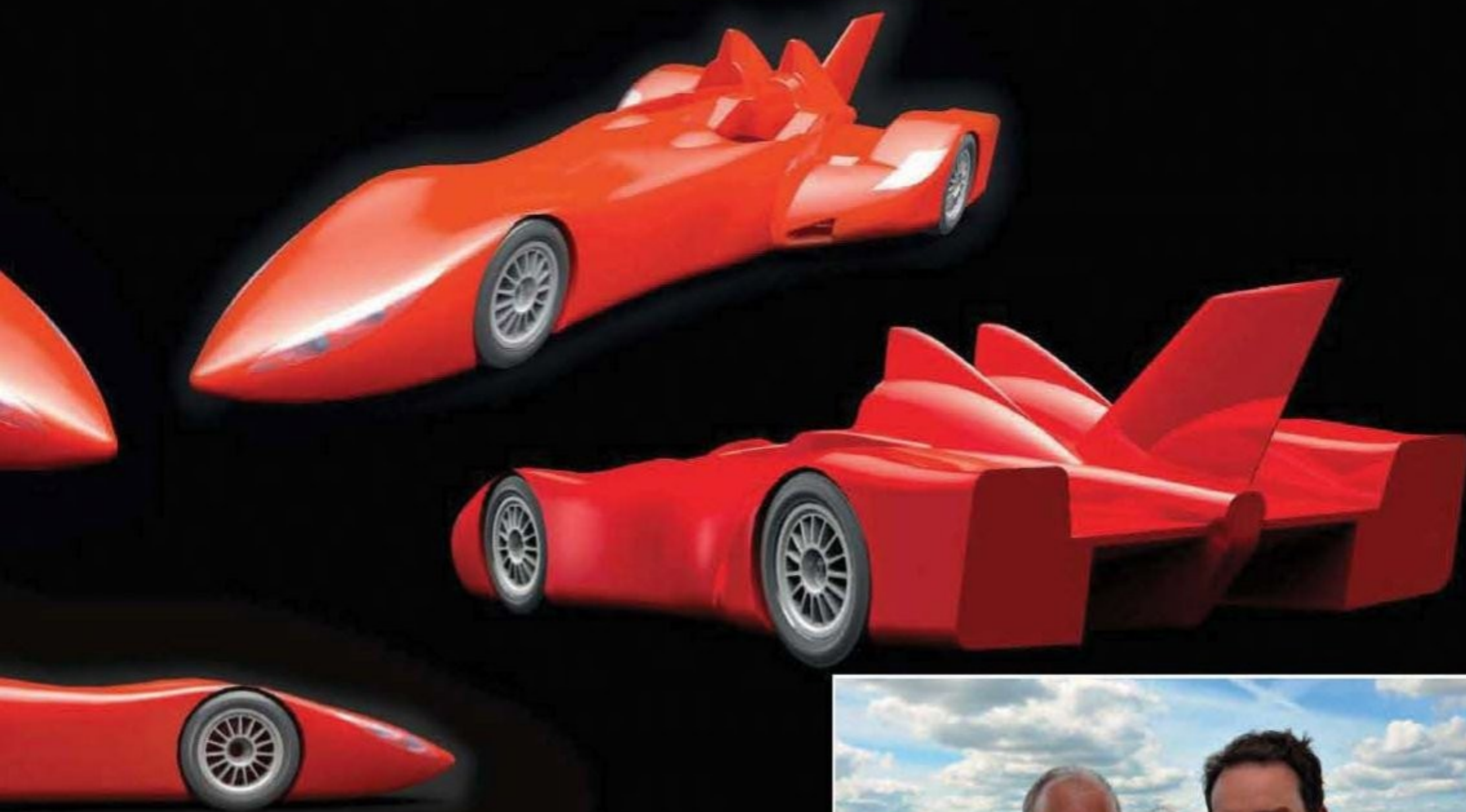

### COSMETIC UPDATES

Beyond needing a new, compliant tub, the majority of the updates to LMP1 spec are cosmetic, as Bowlby explained: 'There really isn't that much we had to do. The car was conceived to be very simple in its design. We've got the same front suspension, the same tyre and wheel sizes. The engine installation is done as a non-stressed installation in its own cradle. We keep that feature, which is great for endurance racing. The engine is only required to generate 300bhp, so that's a very practical and durable power level. You can run that for a long time. The transmission is not stressed so, again, it's very kind to the transmission and engine that they're not bearing chassis loads. The layout of the transmission is still longitudinal for weight distribution purposes. And within the chassis - from

the crash cone at the front to the attenuator at the rear - it's all very modular, which is what you want in sportscar racing for ease of replacement and serviceability. Add in bespoke lighting to suit Le Mans, which is new, obviously, and we are almost ready to take the next step.'

With the LMP1 DeltaWing expected to weigh 475kg dry, its speed and handling will come from the same dynamics as its open-wheel predecessor, thanks to a completely skewed lift-to-drag ratio.

'At 200mph,' explained Bowlby, 'the car should make around double its weight in downforce (950kg) from the floor of the car. We've all but eliminated drag, compared to what is an accepted value for such cars, and with the drag we do have it acts as a stabilising force because it comes from the



Ben Bowlby (right) and Highcroft Racing team owner Duncan Dayton

rear of the car. Everything about the car, though, is inspired by the lack of drag. The lack of wings and the weight and power reduction we've been able to achieve is because we no longer have to combat the air to go quickly in the same way a conventional racecar is required to.'

### EFFICIENT USE OF RESOURCES

Achieving speed through efficient use of resources was the most compelling aspect of the DeltaWing for the ACO and, after years of struggling to achieve parity between diesel and petrol-powered Prototypes,

Bowlby says the French have welcomed a new approach to fuel consumption during the 24-hour race. 'We still only need an 11-gallon (40-litre) fuel cell to achieve the same typical 12-14 lap window between stops at Le Mans. The top speed of the car to achieve the lap times that the ACO are targeting is only around 200mph, so we have already a very low drag form. And because the car is so light and well balanced, our tyre life will be remarkable. The stress on the components will also be lessened, which allows us to save weight, because we aren't saddled with a monstrosity for an engine, or a gearbox that must handle ridiculous torque figures.' It costs an incredible amount of money and time to build a sports car that must defeat the air and carry a

our role is to demonstrate the performance potential of a low drag, low fuel consumption, low horsepower car



# Top Qualifier

Around the world or around the track, you won't find a higher quality line of bearings and rod ends with Aurora's proven 35 year track record.



**Aurora Bearing Company**  
901 Aucutt Road  
Montgomery IL. 60538



Complete library of cad drawings and 3D models available at:  
[www.aurorabearing.com](http://www.aurorabearing.com) Ph: 630-859-2030



Contract manufacturing of high value, high performance components to an international clientele in formula, sports car and rally competition.

Authorized sales, service and testing of Ohlins racing dampers.

Exclusive North American agents for Farrington data acquisition systems.

413.256.0861 Amherst, Massachusetts, USA [www.snapdragonms.com](http://www.snapdragonms.com)

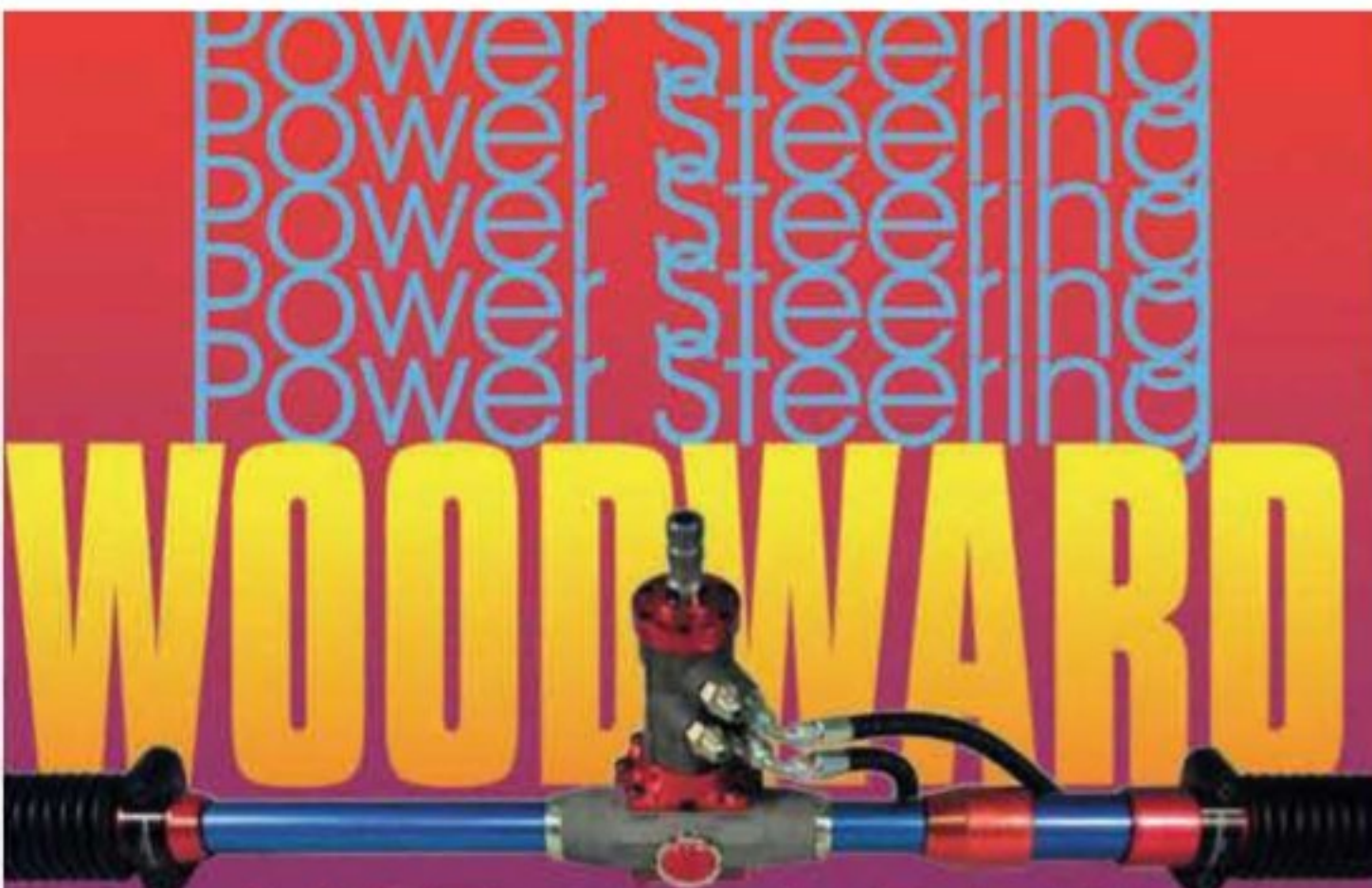

## CUSTOM BUILT POWER STEERING Racks and Components

SERVING MOTORSPORT WORLDWIDE  
from one-off specials to entire racing series

IN USA:



[woodwardsteering.com](http://woodwardsteering.com)

Casper, Wyoming  
phone 1 307 472 0550  
fax 1 307 235 1551

IN EU:



[hydroline.nl](http://hydroline.nl)

Zeewolde, The Netherlands  
phone +31 36 538 72 80  
fax +31 36 522 74 59

Contact: Gordon Riseley  
email: [griseley@ringspann.co.uk](mailto:griseley@ringspann.co.uk)



High Performance

Motorsport

Gearshift & Throttle Cables



RCS

[www.RCScables.com](http://www.RCScables.com)  
Tel 01234 342511

RCS - Cables and Controls



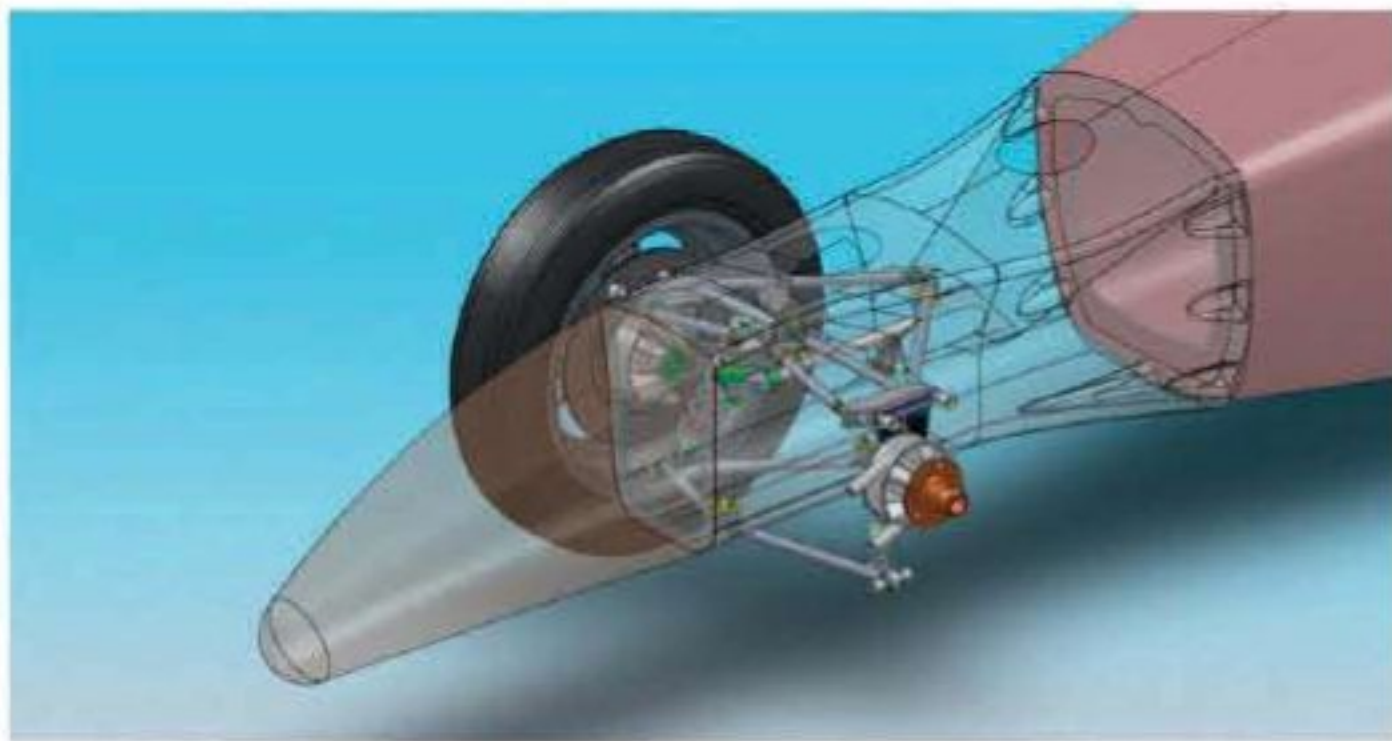
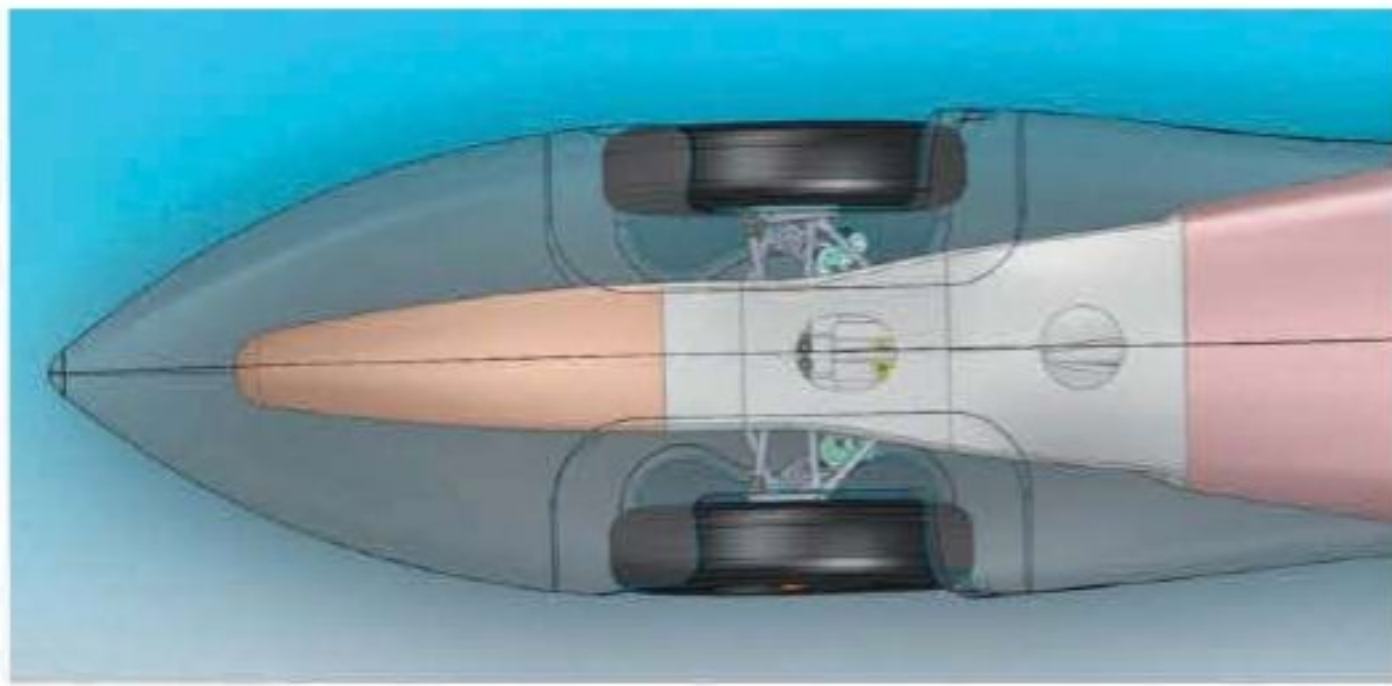

**Downforce is created from the low-pressure area ahead of the rear tyres, with a resultant 24 per cent working on the front of the car**

lot of fuel and generate ridiculous amounts of power. We appreciate the fact that the ACO wants to give people a glimpse of how one can achieve great speeds and great racing whilst thinking small, light and conservative.'

While an engine partner is still being sought, Bowlby affirmed the relatively modest requirements needed from a manufacturer: 'We do not need an expensive, exotic engine to power the car. We can offer a manufacturer probably the most direct, relevant use of its road-car technology at Le Mans in many years. The goal would be to showcase the capabilities of an existing motor, and we are talking with a number of marques that would fit the 1.6-litre / 300bhp bill with a relatively light, turbocharged unit.'

Using a target weight of 70kg for the engine, Bowlby has also kept the design for the DeltaWing's gearbox at a svelte 33kg. 'We're only going to use five speeds,' he said, while confirming that an unnamed vendor had already been selected. 'The torque curve we're anticipating is very flat and we will take the weight advantage and reduce complexity. Running just a five-speed and reverse keeps the gearbox light and small. We spent a lot of time on the

gearbox, which is one of the key elements.'

**TORQUE VECTORING**

Within the transmission, a torque-vectoring differential will be employed to maximise tyre life and to help fine tune the DeltaWing's balance, and Bowlby is quick to clarify this: 'First of all, the car does not need torque vectoring to make the car handle nicely, or to get around a corner. Our idea is to improve handling through a system we call 'efficient torque vectoring'. We don't use braking force with our system. We use planetary gears on either side of the differential. The external ring gear of the planetary set are connected by a shaft with a drop gear, such that we can turn the external ring gear of the planetary gears with an electric motor so we can create no change to the average speed, but can create a differential of speed across both rear wheels to a degree of our choosing. That will be controlled by a simple algorithm that will look at steering angle, lateral acceleration and the car's path.

'The tyres are fundamental, and we're fortunate that we actually have two very interested parties,' Bowlby continued. Bridgestone / Firestone produced tyres for the DeltaWing's full-scale wind tunnel testing, and

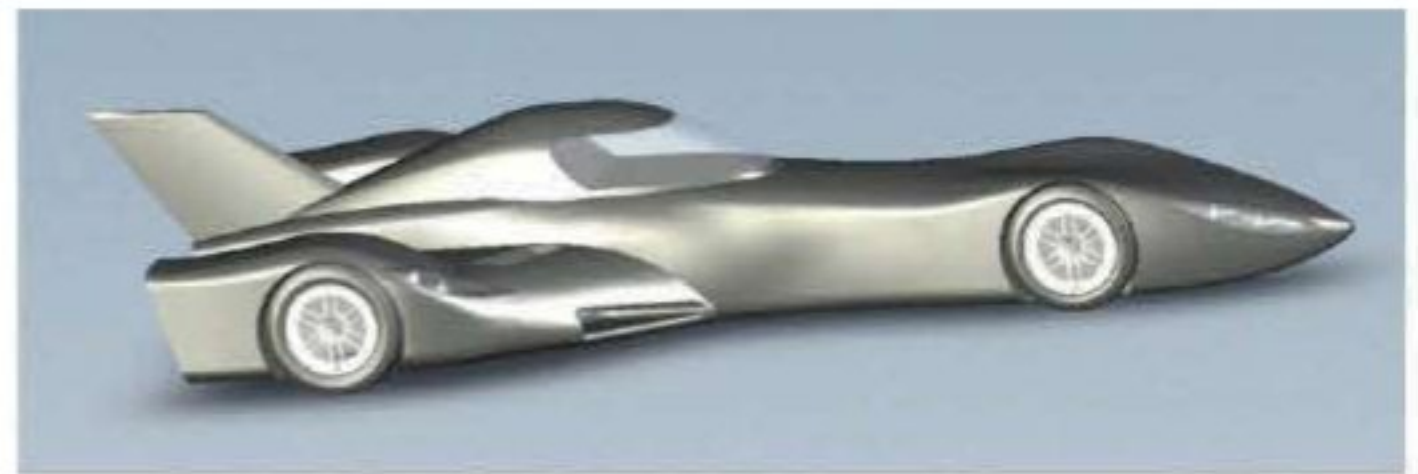

**Bowlby's team penned a coupe version of the car late in 2010, but has opted for an open car which will test in November 2011**

the firm is believed to be one of the manufacturers currently in the mix, along with Michelin. The front tyres, specifically, are vital to the car's performance. With its light weight, incredibly low c of g and long wheelbase, Bowlby has found efficiencies in the size and weight of the rubber needed. 'The tyre story is critical to this whole thing,' he continued. 'Here is a situation where we've got four-inch wide, 15in-rimmed front wheels that are going to allow this car to perform at incredible speeds, whereas the trend in sports car racing, for example, is going to increasingly wider front tyres and to moving weight and aerodynamic balance forwards to maximise the performance within a regulation package. Our trend is going to be exactly the opposite - where we put the weight over the driven rear wheels, move the aerodynamics back in sort of harmony with that weight distribution change and

those terms - that a lot of mass requires a lot of tyre, and very little mass requires much less tyre - hopefully the physics make sense to those who wonder how the car will turn. The fact that the front of the car is light is actually very good for the tyre. The less loading you can place on it through static weight, the better. The majority of the car's mass is located between the rear wheels, which only aids its ability to turn. In many respects, the fact that the front wheels are steering from a long way away - from a long lever arm where the c of g is based towards the back - gives us an enormous ability for the car to change direction quickly, with a controlled response.'

The DeltaWing's lack of front wings has also added to conjectures that the car won't be able to turn at speed, something Bowlby is understandably keen to debunk: 'The aerodynamics are also balanced to match the

**the two-seater LMP1 tub is almost a drop-in fit to the DeltaWing concept**

tyre capacity change, and leave ourselves two very small, equally stressed tyres to handle a very small amount of mass and a very small amount of aerodynamics. We are using most of the tyre capacity on the car all the time.'

**BUT WILL IT TURN?**

The bane of Bowlby's existence has been this very question. And his answer has been refined over the past 16 months: 'Yes, the car will turn... The tyre capacity at the front of the car is matched to the mass it carries. The tyres are saturated with as much work as they are required to do, as the rears are. If you push laterally on the car, it doesn't have a yaw moment. If you think of it in

weight and mass of the front of the car. First, it's true that absolutely no downforce is created off the nose of the car. It's created off the low-pressure area ahead of the rear tyres. Because of the location where we make the downforce - directly under the car's c of g and ahead of the diffuser - we end up having about 24 per cent of the aero acting on the front of the car. You don't have to create downforce at, or ahead of, the front wheels, like you would with traditional wings, for there to be downforce applied to the front of the car. That's a myth. The centre of pressure is ahead of the rear wheels, but that doesn't mean that pressure isn't applied to the



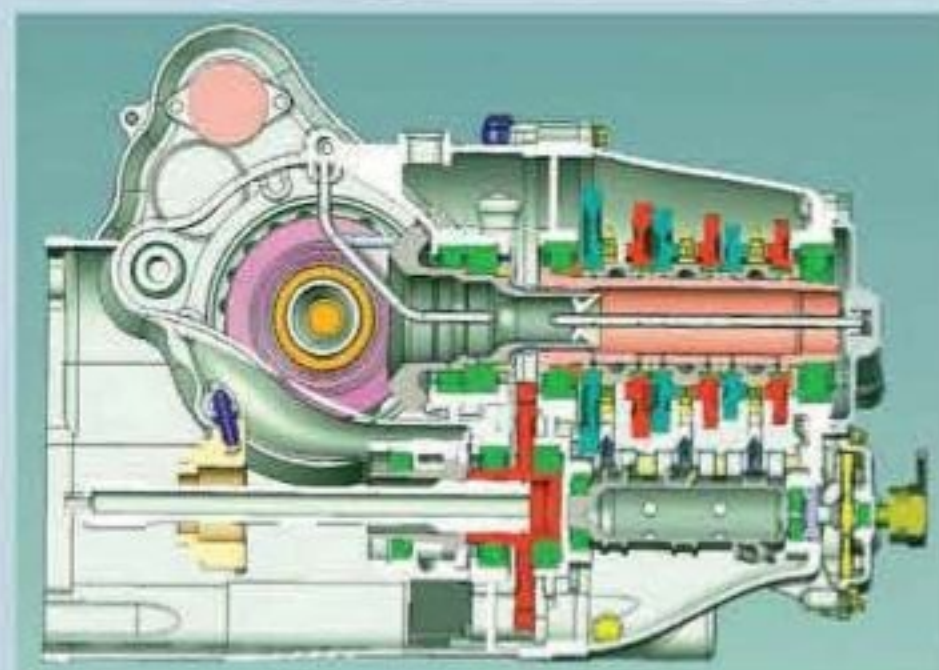
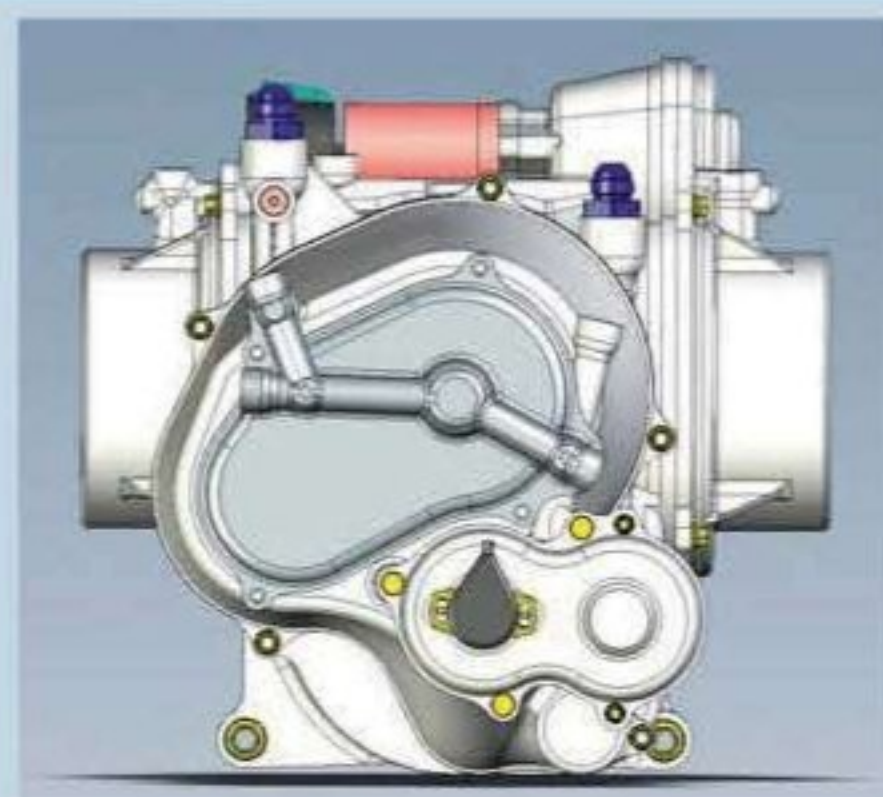
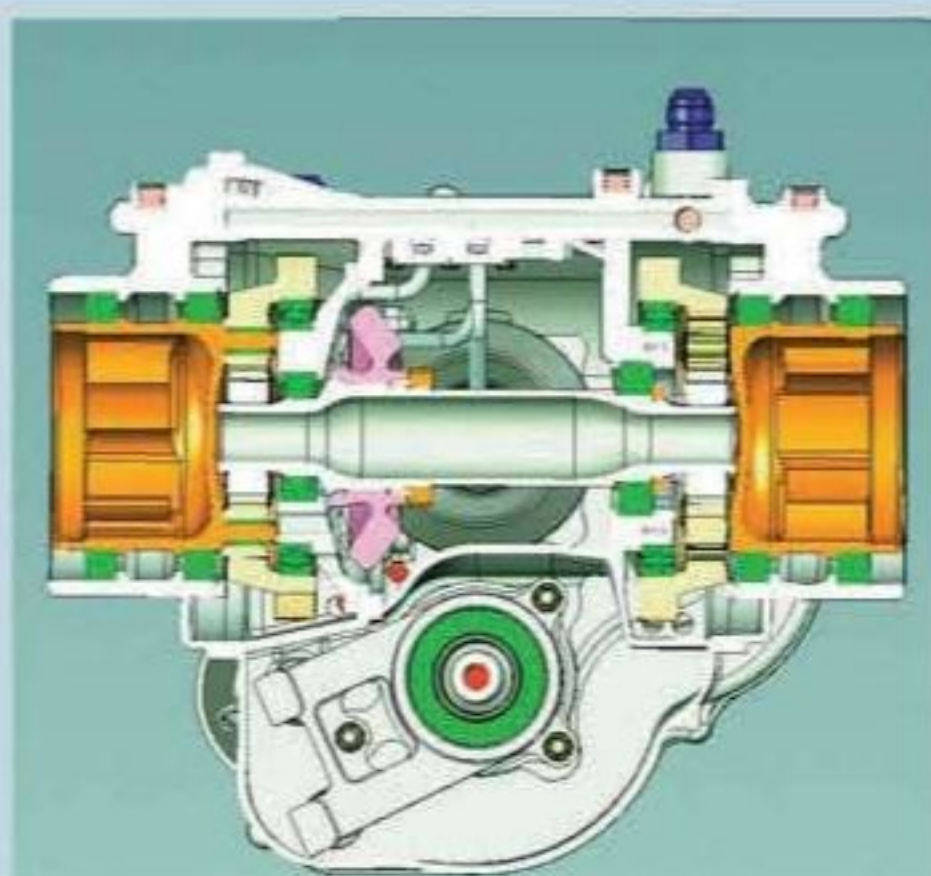
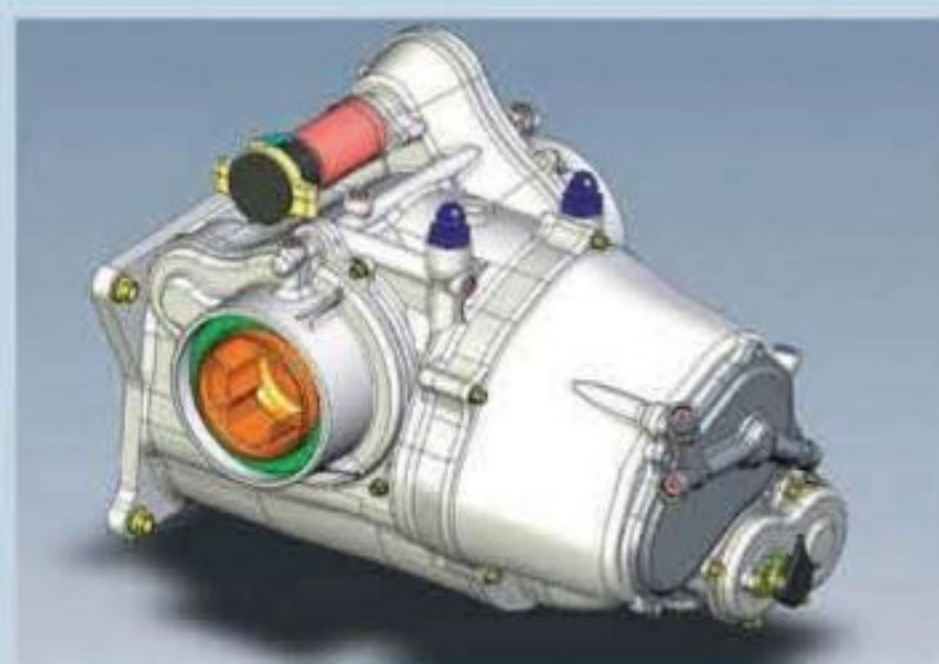

The DeltaWing transmission is a longitudinal unit with only five speeds. It is mounted in the conventional location and a manufacturer has been appointed though not yet named

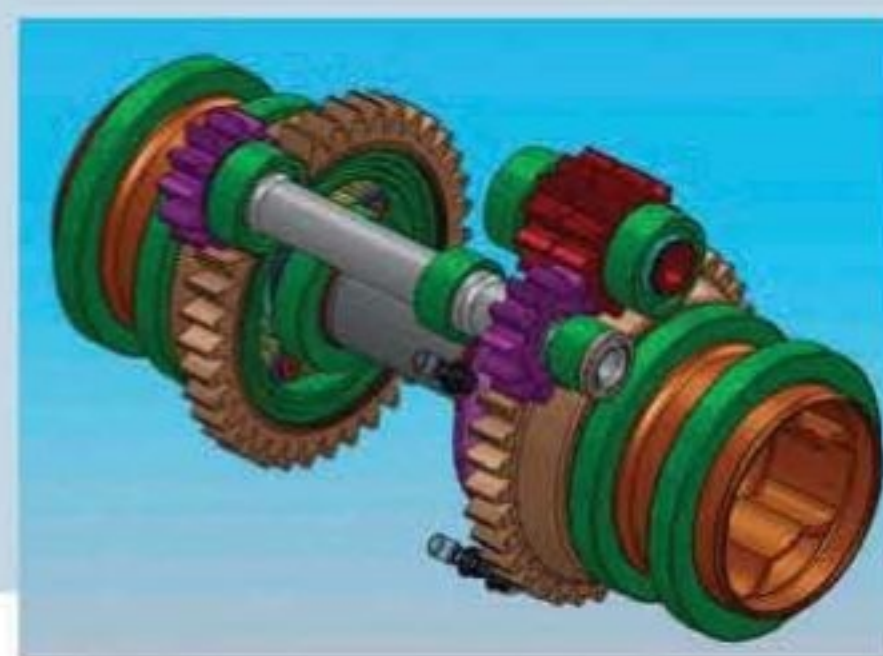

front wheels as well. The floor of the car makes the downforce as a whole, and that downforce is applied to all four wheels.'

'The braking is amazing because you can brake with a great amount of confidence from very high speed into the Mulsanne chicanes,' said Bowlby. 'We'll have to watch our total brake wear, and that's something we're going to have to learn a bit more about before we're finished. For a fast lap, you can leave the braking very late and achieve a very impressive corner entry speed. And that's partly due to the intrinsic stability of having more braking behind the c of g than in front of it, which is actually a unique characteristic. I don't think there's any other circuit racecar that has ever had more braking from the rear than the front. Obviously, racing karts have rear brake only, but that's a slightly different case.'

**DEMONSTRATION ASPECT**

Due to the DeltaWing running as an unclassified car at Le Mans, a number of construction and performance parameters remain unsolved, as Bowlby noted: 'We've gone through to make sure that we meet standard FIA Sportscar regulation crashworthiness parameters, but we have not yet embarked on a detailed dialogue with the ACO on the specifics of meeting their performance requirements.

Because we're running out of regular competition at Le Mans, our role, as I understand it, is to demonstrate the performance potential of a very low drag, low fuel consumption and low horsepower car. The 'demonstration' aspect of what we're doing means we do not have an exact set of parameters to build against. Once those are set, the final tub design and the rest of the car will be completed and we will begin production.'

Bowlby and the ACO are also keenly aware that edging too close to the established LMP1 titans could cause political problems and, as a result, they expect to fall behind the likes of Audi and Peugeot on the

**we do not need an expensive, exotic engine to power the car**

time sheets. 'First of all, we can absolutely achieve LMP1 performance,' said Bowlby. 'As we back off from that to meet whatever requirements the ACO stipulates, the first thing that will happen is that we'll improve our fuel efficiency because the ACO aren't going to ask us to make a less efficient car, they're simply going to say, "you need to run at this lap time," and I'm assuming it will be at a pace that works

harmoniously with all of the other LMP competitors at Le Mans. The DeltaWing project is not intended to prove whether we can go faster than certain cars, it's to demonstrate that we can be in the general ballpark with a completely different design philosophy. According to our simulations, we can absolutely run in the 3:40-3:45 lap time range in a consistent and highly efficient manner, or whatever the ACO desires. Ultimately, we are their guests and under their direction.'

Based on the impact threshold the DeltaWing is required to withstand, Bowlby will finalise the construction materials used throughout the

car's design. With Panoz's REAMS body panel technology, look for a blend of carbon, Kevlar, aluminium and titanium fore and aft of the main chassis bulkheads to carry the respective front suspension and drivetrain modules.

Having the name of Dan Gurney and All American Racers attached to the project is a public relations coup, but from a practical standpoint, the choice

of a once-relevant sportscar and open-wheel constructor that hasn't produced a racecar for more than a decade could seem like a mistake by the Project 56 team. But in the days since AAR produced its last CART IndyCar chassis, the Southern Californian facility has expanded its production capabilities.

While Gurney could not speak on the record regarding AAR's current production contracts, it would be safe to infer that the company possesses all of the state-of-the-art machining, fabrication and composites expertise to provide large scale, high-tech, lightweight solutions to the United States military. "I can't get into this area," said Gurney, "but my son, Justin, has been in charge of expanding and developing that part of our business. But I can tell you we're plenty capable of producing the DeltaWing Prototype and whatever else is needed. We're proud to be able to build the car, and I can't wait to return to Le Mans to see it race. I've been down that road before with something different and new, but if you spend too much time listening to the people who tell you it won't work, you'll never get anything done. We're going to build this car and go show people what the human mind and good old-fashioned ingenuity can do at Le Mans.'





## Aston Martin LMP1 and a 3D Printer

"Without the 3D printer, we would not be testing the car today."  
*George Howard-Chappell, Technical Director at Aston Martin Racing.*

Stratasys Inc., says Aston Martin Racing was able to meet an aggressive development schedule for their AMR-One race car by using 3D printing. The company's Dimension 3D Printer was used to mock up the chassis, driver controls and engine of the race car. The 3D Printer produced prototypes for concept and testing of the Aston Martin AMR-One (LMP1 class). Developed in under six months, the car was driven by the Aston Martin Racing works team of drivers in the 2011 Intercontinental Le Mans Cup (ILMC).

For further information on the Stratasys range of Dimension 3D Printers, please contact:

Mark Tyrntania  
markt@laserlines.co.uk  
01295 672515



**laserlines**



## CONGRATULATIONS!

**MoTeC would like to acknowledge the efforts of all of our valued customers who took part in the 2011 Le Mans 24 Hours.**

Special congratulations to Rebellion Racing and the drivers of the #12 Lola for achieving the honour of first petrol powered car across the line, with an impressive 6th place outright.

In LMP2 we'd like to give a special mention to the #26 Oreca 03-Nissan of Signatech for taking 2nd in class, and the Lola-HPD of Level 5 Motorsports for 3rd. In fact, MoTeC electronics were on board seven of the top eight LMP2 finishers, including Oak Racing's two Pescorolo-Judd entries.

In GTE Am we congratulate the team and drivers of the #70 Labre Competition Porsche for a second place finish, and the Doran Ford GT of Robertson Racing for rounding out the podium in 3rd.

**Terrific results that we're proud to acknowledge!**



## HARNESS OUR EXPERTISE



**PHOENIX  
DYNAMICS  
LIMITED**

Design, manufacture and test of high performance electrical systems.

Proven expertise in the development of products for harsh environments and high reliability applications.

Products include wiring harnesses, power cables, electro-mechanical assemblies and test equipment.

Tel: +44 (0)1782 578333  
sales@phoenixdynamics.com  
www.phoenixdynamics.com

Images thanks to Oak Racing and Signatech



[www.motec.com](http://www.motec.com)

**Race smart.**

ENGINE MANAGEMENT • DATA ACQUISITION • POWER DISTRIBUTION





**KMS**  
**Kronenburg Management Systems**



**Kronenburg Management Systems (KMS)** is a complete line of engine management systems, that offers you an extremely reliable and user-friendly system at a very competitive price. It gives you the possibility to manage all (turbo + n/a) petrol engines up to 12 cylinders with options such as 4mb datalogging, staged/banked injection, mapselector, odd firing, self-learning lambda control, boost control, variable launch control, idle control, traction control, powershift, rpm limiters, engine diagnostics, shift-light, water injection, cooling fan, fuel pump, etc. New KMS CAN display, UEGO CAN controller and MAP sensors now available.

For more information, free software and prices:

<http://kms.vankronenburg.nl>



**KMS Management Systems**  
Spaarpot-Doot 19, 5667 KT Geldrop, The Netherlands  
T. +31(0)402854064, F. +31(0)402867765  
E. [info@van-kronenburg.nl](mailto:info@van-kronenburg.nl)

**DOCKING**  
**Advanced Cooling Systems**

**Water Radiators  
Intercoolers  
Oil Coolers  
Heat Exchangers  
System Design  
Ancillary Products**

Manufactured to your requirements by the UK's leading supplier.

**25 YEARS**  
SERVING MOTORSPORT SINCE 1984

Tel 00 44 (0) 1327 857164  
Fax 00 44 (0) 1327 858011  
Website [www.dockingengineering.com](http://www.dockingengineering.com)  
Unit 15 Silverstone Circuit • Silverstone Northants • NN12 8TL • United Kingdom

**PRO-SHIFT**  
electronic gearshift

Championship Winning  
**Semi-Automatic Electronic Gearshifters**  
for Racecars & Superbikes

Now available  
This superfast and highly sophisticated  
**Gearshifting PS3 Paddleshift System** suitable  
for **Racecars and Superbikes** with over 170  
adjustable parameters

**PS3 System**  
Offering Fully Closed Loop Gearshifting for  
both Racecars and Superbikes

**Auto-Blip & Downshift Lockout**  
For clutchless downshifts plus engine over-rev protection

**Graduated Ignition Cuts**  
Individually programmable for all gears

**Auto Upshift Facility**  
Max power upshifting at full throttle...!

For more information:  
email: [info@proshift.com](mailto:info@proshift.com)  
telephone: +44 (0)1332 668100

[www.proshift.com](http://www.proshift.com)

**EARL'S**  
PERFORMANCE PRODUCTS

CUSTOM BRAKE LINES | OIL COOLERS | HOSE | FITTINGS  
ADAPTERS | FILTERS | NOS | FUEL PUMPS & REGULATORS

FUELAB NOS Holley EARL'S ACCEL WAZZS STÄUBLI

Visit [www.earls.co.uk](http://www.earls.co.uk) for the full range  
Online Shop now Available

**Earl's Performance Products UK Ltd**  
Units 15-16 Silverstone Circuit, Northants, United Kingdom NN12 8TL

+44(0)1803 869850 | [sales@earls.co.uk](mailto:sales@earls.co.uk)

QUOTE "RCE10"  
WHEN ORDERING TO  
RECEIVE 5% DISCOUNT





# Joint effort

Built in England with British and Japanese engineering, the VK45DE heralds a new direction for sportscar engines

To go 3.353 seconds a lap faster than one's nearest rival is certainly a statement of intent, even when there are only four starters. But that was what happened at the Sebring 12 hours in March, the opening round of the American Le Mans Series. Soheil Ayari set the LMP2 pole position time in the Signatech ORECA, powered by the new Nissan VK45DE engine, giving a clear indicator for the rest of the season. Weeks later on the European side of the Atlantic, the engines were

BY IAN WAGSTAFF

performing just as well; at the 6-hour race at Le Castellet, southern France, the top three LMP2 places in qualifying were held by Nissan-powered teams. During the race, one of those teams, Greaves Motorsport, went on to win the LMP2 class, and finished on the overall podium.

This year's race at Sebring heralded a new era in which former 3.4 litre normally aspirated and two litre turbo LMP2 engines were elevated to

LMP1, and all power units for the class now have to be based on engines homologated for GT racing cars.

Engine manufacturers complained bitterly, claiming that the road-based engines were more expensive to develop for racing purposes, but the governing bodies stood firm, and companies such as Zytek were forced to search for an alternative solution.

The British company had to ditch its Le Mans Series title-winning ZG348 V8 engine, which also won its class at Le Mans.

## TECH SPEC

<b>Nissan VK45DE</b>
<b>Configuration:</b> V8, 90 degree
<b>Capacity:</b> 4494cc
<b>Valves:</b> 32
<b>Power:</b> 450bhp at 7,000rpm
<b>Torque:</b> 580Nm at 6,800rpm
<b>Crank:</b> bespoke flat plane
<b>Restrictor:</b> 40mm
<b>Oil:</b> Motul
<b>Intake:</b> bespoke, direct injection
<b>Ignition:</b> Zytek electronic
<b>Weight:</b> 150kg





The 32-valve, 90-degree V8 engine is currently running successfully in ORECA and Zytek chassis, with Zytek Engineering having exclusive rights to supply and service the engine in Europe and North America

The Derbyshire-based manufacturer had already developed a good working relationship with Japan as it supplies the EGS (Electrically-Assisted Gearshift System) for use in Japanese Super GT and Formula Nippon and also the development KERS for the Honda NSX GT FR Hybrid. There are close personal links between the two companies and so it was a natural choice to opt for a Japanese partner.

While Zytek looked at various options, including both V8 naturally aspirated and V6 turbocharged engines, it was Nissan's Super GT engine that was selected.

Mid-2010, the two companies began to talk, and there was more to this than just an existing relationship: 'We wanted to go with something that we felt was good, reliable technology,' says Zytek Engineering operations director, John Manchester. The appeal of the Nissan engine was

that it had already proven itself in Super GT, and in 2008 had won said championship. With all the other engines examined, none had a racing pedigree of any kind and, observes Manchester, 'there would have been an element of risk and also extra cost involved.'

Although any new LMP2 engine was to be available for a

**“ [it] is a very conventional V8... What we have done is to make the engine very efficient ”**

variety of LMP2 chassis, it was understood that it should also fit into the company's own cars. The Nissan unit also ticked that box, and so a deal was signed at last year's 1000kms of Silverstone. Zytek now has the exclusive rights to supply and service the VK45DE in Europe and North America for the Intercontinental

Le Mans Challenge, Le Mans Series and American Le Mans Series, and the Le Mans 24 hours.

Since then, Zytek has worked in close conjunction with NISMO on the development of this new flat plane crank engine, sending engineers to Japan and vice versa. The first test engine was built in December in Japan and

completed 6000kms on the test bed. The following month, engine kits commenced delivery to Repton, UK, where they were assembled.

Four cars - three ORECA's and a Zytek chassis - were running with the new 32-valve, 90-degree V8, 4494cc Nissan engines by March, something

that Manchester admits was not anticipated. To the Signatech Group's ORECA that had taken pole at Sebring could be added at Paul Ricard cars from Boutsen Energy Racing, TDS Racing and Greaves Motorsport. Together they made up a third of the LMP2 field for the LMS opening round.

#### **BUILDING TO A COST**

In Super GT racing guise, the engine is extremely expensive, so the LMP2 design had to be cheapened to enable it to meet the new cost cap regulations. These engines can only be sold for a maximum price of 75,000 Euros (£66,000 / \$108,280), so Nissan and Zytek had to be able to build the engine under this price cap, which is the same for every engine supplier in the class.

As Manchester points out, you cannot take a standard road car V8, insert it into a Le Mans Prototype and expect it to do 6000kms. 'It just would not happen, it would break. Standard



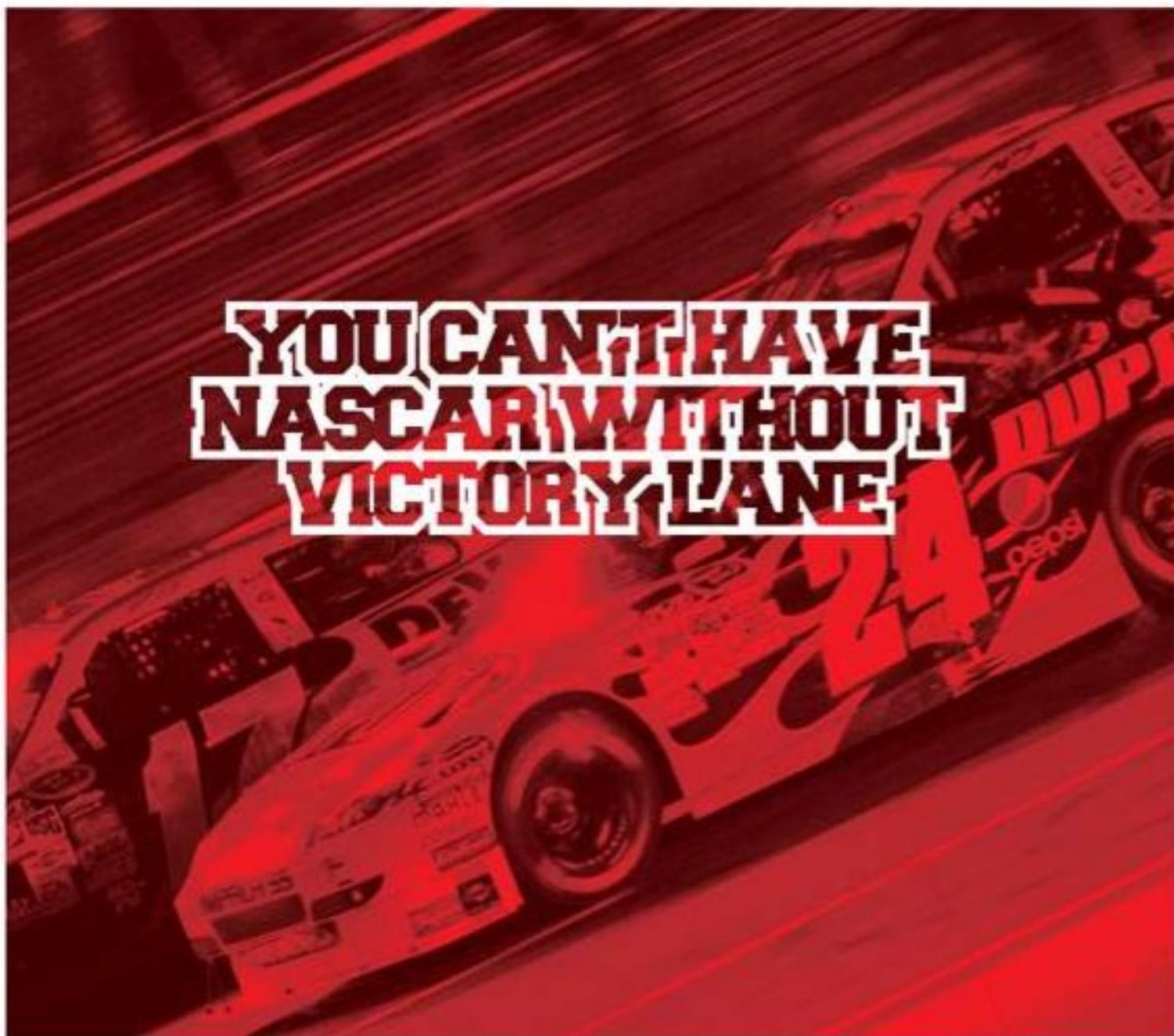

**YOU CAN'T HAVE  
NASCAR WITHOUT  
VICTORY LANE**

**dc**  
electronics

turning power into performance

**YOU CAN'T GET TO  
VICTORY LANE WITHOUT  
DC ELECTRONICS  
WIRING LOOMS**



Design and build of race car electrical systems since 1996 including ALMS, GRAND-AM, SCCA and Formula One.

- o Manufacturers of wiring harnesses to suit the new McLaren spec NASCAR ECU
- o Suppliers of engine management sensors
- o US based engineers available for trackside/raceshop support
- o Design and supply of test car data acquisition systems

**Distributors for:**

Braille Battery, DTA, GEMS, MoTeC, OBR Control Systems, Pectel, Pi Research, Race Technology, Stack, Variohm EuroSensor

**USA**

Kinetic Racing Technologies  
Scott Jasmund  
52 Raleigh Drive, Palm Coast  
FL 32164 USA  
T +1 (248) 245 2330  
E support@kineticracing.com  
www.kineticracing.com

**UK & Europe**

DC Electronics - Motorsport Specialist Ltd  
David Cunliffe  
Unit 1+2 Quayside Industrial Park  
Maldon, Essex CM9 5FA  
T +44 (0) 1621 856451  
E sales@nascarwiring.com  
www.nascarwiring.com

**ATLL**

**ATLL RACING FUEL CELLS**

**PROUD SUPPLIER TO EVERY F1 TEAM!**

**PLUS OFFICIAL SUPPLIERS TO:**

- > BTCC (BRITISH TOURING CAR CHAMPIONSHIP)
- > STCC (SWEDISH TOURING CAR CHAMPIONSHIP)
- > DTM (DEUTSCHE TOURENWAGEN MASTERS)

**ATLL UK**

Tel: +44 (0)1908 351700  
sales@atlltd.com  
www.atlltd.com

**ATLL USA**

Tel: +1 201 825 1400  
atl@atlinc.com  
www.atlinc.com



**ATLL**





Based on a standard Nissan road car block and heads, the LMP2 engine uses bespoke crank, rods, pistons and intake for maximum efficiency

## THE COMPETITION

➤ The Nissan VK45DE has two competitors in LMP2. Engine Developments has made use of BMW's V8 - a 4.0-litre in road going form - for the Judd HK. The limitations of the Honda range have forced HPD to use a 2.8-litre V6, twin turbocharged for racing. At the start of the season, the five per cent air restrictor advantage given to the naturally aspirated engines of the lighter, cost-capped ORECA's and the

Zytek gave them a distinct advantage. After Paul Ricard, the ACO gave the HPD's a restrictor break of 1.2mm, increasing it in size from 28.1mm to 29.3mm. Prior to Le Mans it was also felt that the Judd's restrictor should also be adjusted to 42.4mm. In qualifying for the 24 hours, an ORECA-Nissan still proved quickest but Strakka's HPD was next, just over a second adrift, while the fastest Judd was 1.7 seconds behind.



Engine specialists have been forced to use production-based blocks. Judd opted to use the BMW V8, 4.0 litre in road going form.

components like crankshafts, rods and pistons are not made for that kind of durability. An average lap of Le Mans is around 70 per cent on full throttle, meaning that a huge amount of load goes through such parts, so you have to fit bespoke parts.'

NISMO specifically asked Zytek to manufacture various external and internal parts, under Nissan design, for the engine. The new regulations limit what can be done, and every new part has to be homologated by the ACO. Some work has been done on the cylinder block in terms of crankshaft retention, including different main caps. Likewise, there has been some work to the standard cylinder head and the valvetrain, but a large amount of the parts, including the crank, rods, pistons and the intake system are bespoke to

pointing out that a Zytek 3.4-litre ZG348 LMP1 engine weighs 125kg, while the Nissan version tips the scales at just over 150kg. That may be predominantly because it has a production-based cylinder block and heads, but there are plenty of parts in the engine that could be made lighter, were it not for the cost cap.

The engine has shown up well on the test bed, and now on the track too, but Manchester believes there is still much room for further improvement, especially with Zytek and Nissan now working on joint development programmes. 'I think we have only just scratched the surface of this engine for LMP2. We are now starting to look at various different areas of development - the type of work that you would do on any racing

“ we don't know where this is heading. It may lead to other racing programmes in the future ”

LMP2 regulations. Naturally, it is also dry sumped, unlike the road car version. Because of the regulation air restrictor, its maximum power is 450bhp and its maximum torque 579Nm.

'It's based on a standard road car engine, so is a very conventional V8,' admits Manchester. 'What we have done is to make the engine very efficient.'

### AREAS OF COMPROMISE

He also points out that performance comes at a cost so, to keep under the price cap, LMP2 engine manufacturers have to compromise. 'Reliability is of paramount importance in any sportscar engine,' he says. 'It is only when this is achieved that the company can look at the performance.'

In the case of the VK45DE, compromise has been achieved through manufacturing techniques which have led to slightly heavier parts. 'They could have been made lighter, and the gear train could have been different,' adds Manchester,

engine. We are learning about it. Every engine has its own idiosyncrasies and you have got to understand them. As we do that it will get better and better.'

Nissan was last seen as part of a full factory programme at Le Mans in 1999, yet there had been times during the 1990s decade when the Japanese company had been amongst the favourites to win the 24-hour race outright. So, does the company's re-entry into this style of racing herald another, future attempt at sportscar racing's ultimate crown?

'It is the very early days of what already is a strong partnership,' replies Manchester. 'We don't know where this is heading. It may lead to other racing programmes in the future, but for now our main focus is to make this engine the best in the class.' Whatever the future holds, it indicates a new approach, as this is the first time a NISMO power unit has been built outside Japan by another engine manufacturer.





## NEXT GENERATION DATA ANALYSIS



- > Race proven systems
- > Very high data rates
- > Fully customisable
- > Analysis software included



[www.gems.co.uk](http://www.gems.co.uk)



Fitting & Hose Systems

## ...one step ahead



### High quality hose assemblies

- All race series F1, ALMS, WTCC, WRC
- 100% pressure tested
- flushed to NAS on request



### Airjack system - quick lift

- Most lightweight – only 962g at 230mm stroke
- fastest actuation – by 40bar pneumatic pressure
- Highest safety – by integrated pressure relief valve



### Steering wheel quick release

- Only 272g
- Conical seat - free from play
- Easy to connect by ingenious mechanism



### Bespoke parts

- CNC turning and 5-axis milling machines
- short delivery times
- full traceability



### NEW online shop

- delivery from stock
- easy order system
- worldwide delivery service

**New facility in the UK**

KRONTEC Design Ltd., Phone: +44(0) 17 93-42 20 00

[www.krontec.com](http://www.krontec.com)





# Audi's secret weapon

A technological breakthrough which made the German marque's victories at Le Mans in 2010 and 2011 possible

**W**hen Audi Sport decided to replace the R10 TDI with an all new car, the R15, it required an all new engine. The V10 diesel required one thing to gain an edge over arch rival Peugeot; cutting-edge turbocharger technology.

The development of a turbocharger capable of winning at Le Mans, especially within the limitations imposed by the regulations such as restrictor diameter (maximum air-flow rate)

and boost pressure, as well as the creation of a complex exhaust turbocharger control system for transient racing operation, placed extremely high demands on the engine development. As a result, significantly more importance was attached to the turbocharger regarding throttle response, modulation and power delivery. In addition to the layout providing for the most favourable efficiency, the turbocharger would have to fit perfectly with dimensional constraints (maximum air mass) and the

required usable engine-rev range. To achieve the desired results Audi Sport partnered with turbo specialists Honeywell.

Turbochargers have a handicap in that their optimum working range falls within a relatively narrow engine rev range, and a turbocharger with its optimum working range at higher engine revs will yield deficits in boost pressure and throttle response at low engine revs.

For the R15, Audi Sport introduced a completely new turbocharger with variable

turbine geometry (VTG). Development on this had been carried out in cooperation between Engine Development Audi Sport and Honeywell/Garrett, based in Torrance (USA) since 2007, although Audi only revealed its installation on the R15 in 2010 after it had won the Le Mans 24 hours.

During the VTG development significant progress was made through the choice of a suitable turbine. Compared to an exhaust turbocharger with a wastegate, exhaust gas back pressure was





# Anti-lag systems are a total waste, the technology is 30 years old and it is rubbish

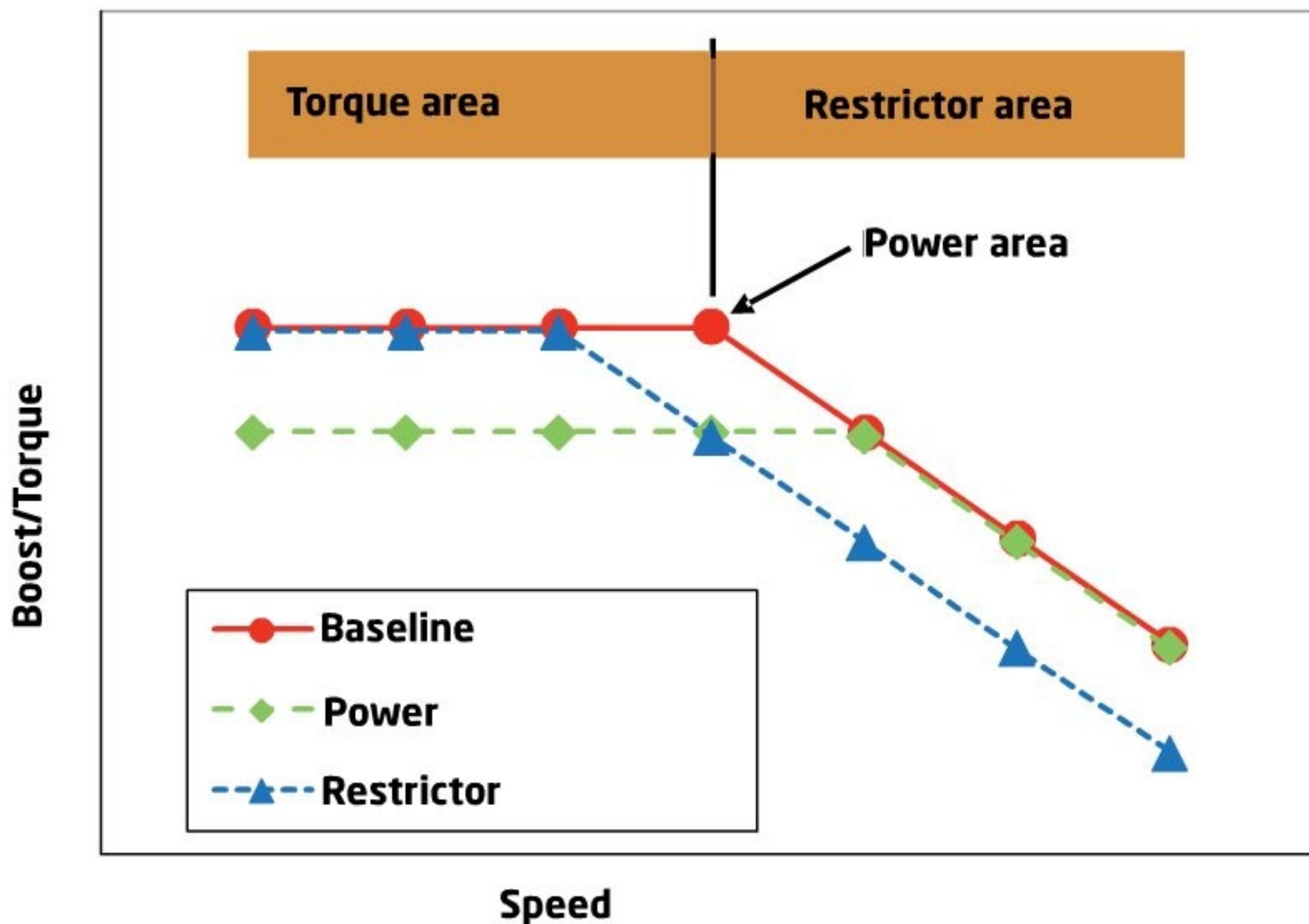

reduced by up to 15% throughout the entire rev range. Additionally, the lower threshold of the rev range, where maximum boost pressure is available, could be reduced by 250rpm. As a result, the complete package of compressor and VTG turbine increased engine power by approximately 2%, and created a more favourable specific fuel consumption of around 4% (overleaf).

### ROAD TO RACE

Turbochargers with variable turbine geometry are unusual in motorsport, though they are commonplace in road going vehicles, and much effort (most of it confidential) has been expended by both Audi and Honeywell on the racing units. 'The problem is temperature,' explained Ulrich Baretzky, Audi Sport's Head of Engine Technology. 'Because road cars have an exhaust temperature of a maximum of 800 degrees, it is easier to deal with, but when you go up to 1,000C like we have done, then things become really, really complicated. It's a

While only restrictor cross-section is regarded as gauge for the rated power output of normally aspirated engines, it is the interaction between restrictor diameter and maximum boost pressure that is decisive for turbo engines. A reduction of the air mass and/or power through decreasing the restrictor cross-section leads initially to a reduction of the nominal rotational speed for identical swept volume. A reduction of boost pressure or torque requires an increase in the nominal rotational speed. In contrast, an increase of the nominal rotational speed results from a reduction in the boost pressure or torque

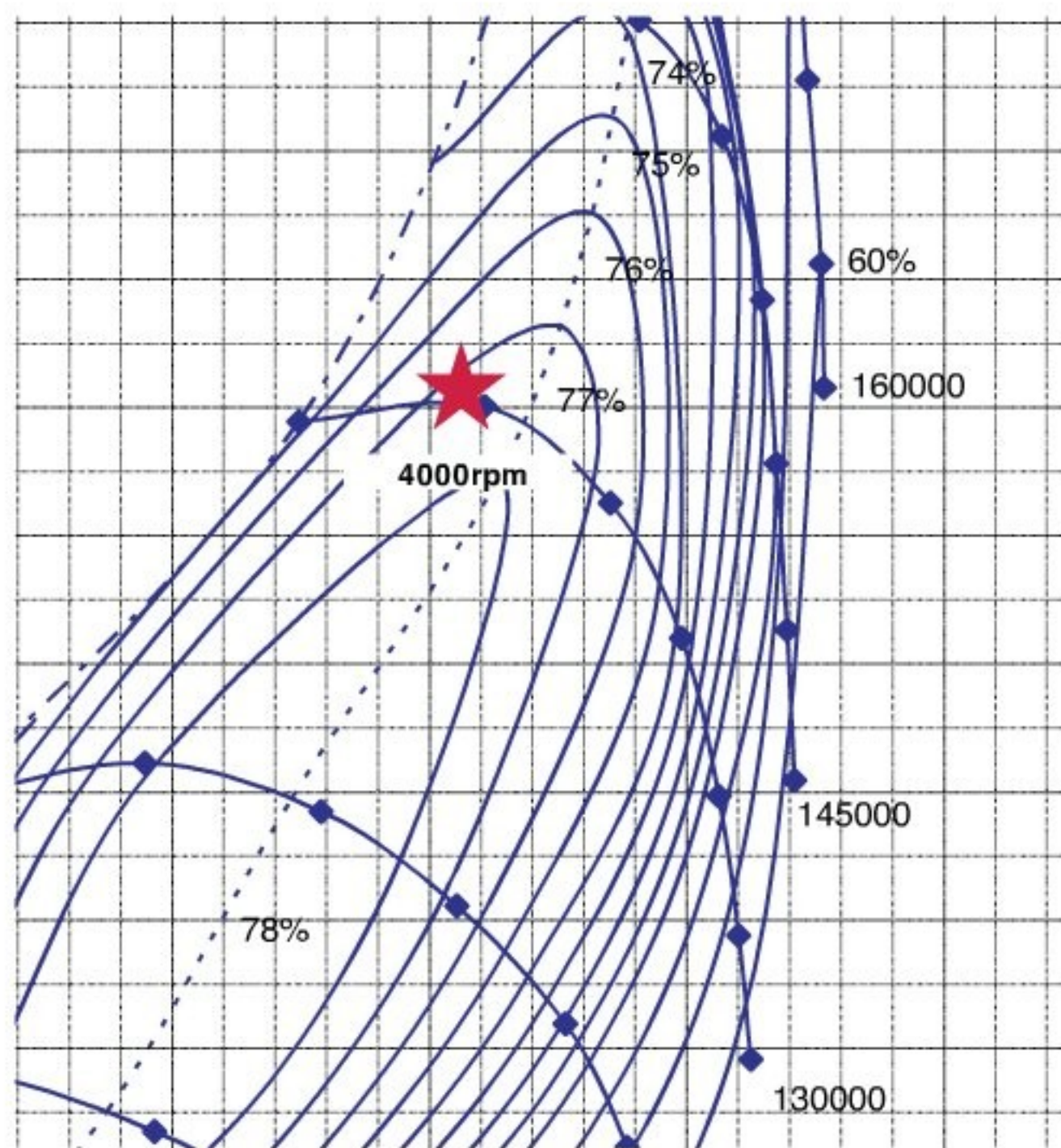
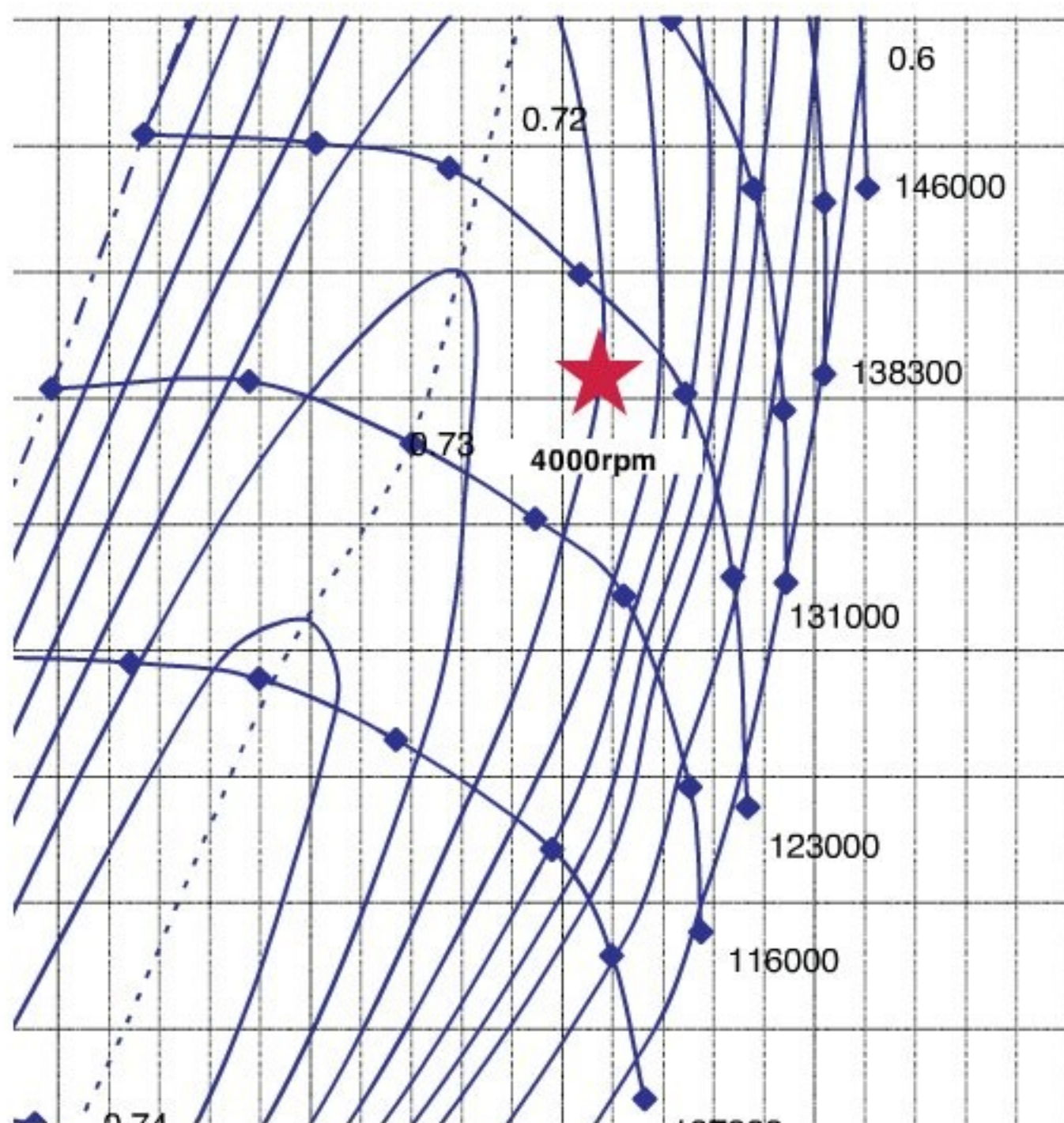

Here two compressor maps are compared. Left the old design for the wastegate exhaust turbocharger, right the new optimised compressor for the VTG-exhaust turbocharger. Additionally, the engine operating point in the rated power output range is indicated. The approximately 5% greater efficiency is clearly visible. It is available throughout almost the entire full load range. The optimised compressor allows approximately 8% more exhaust turbo



**"Who Works in" Guides**

# Your Access to a fast moving world

The only reference books that keep you updated with motor racing

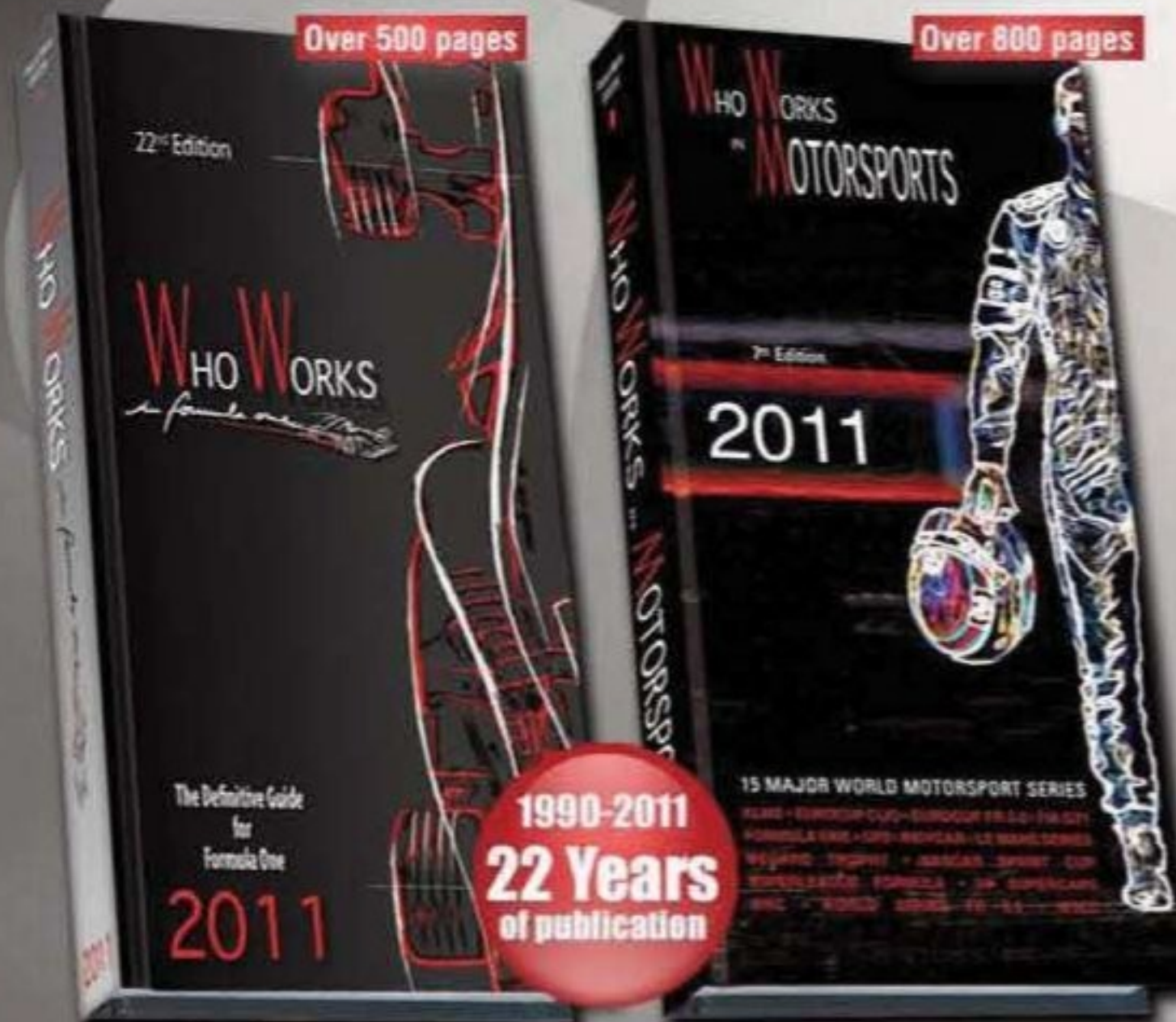

**Each new edition 100% researched & updated !**

In depth information on the major players of the 2011 field.

Teams, drivers, engine manufacturers, cars, key people, sponsors & suppliers, media, marketing & PR, organisers, circuits, officials, etc.

Company details including logos, key people with color portrait pictures & contact details, addresses, websites, and a lot more.

**Order now on our secure website - [www.whoworksin.com](http://www.whoworksin.com)**

## **AERODINE** COMPOSITES GROUP



ADVANCED COMPOSITE TECHNOLOGIES  
FAA CERTIFIED REPAIR STATION RDMR624X

- STRUCTURAL COMPOSITE ENGINEERING
- PRODUCT & TOOLING DESIGN
- CAD/CAM
- FINITE ELEMENT ANALYSIS
- PROTOTYPING
- MANUFACTURING
- STRUCTURAL REPAIR

*Serving the Motorsports Industry Since 1989*

[www.AerodineComposites.com](http://www.AerodineComposites.com)

Tel. +1 001.317.271.1207 • Fax. +1 001.317.271.4455

8201 Indy Lane, Indianapolis, IN 46214

## **RACEPARTS**

We can supply all the parts...



**...You just need to put them all together!**

**2011  
Motorsport  
Catalogue  
now  
available**

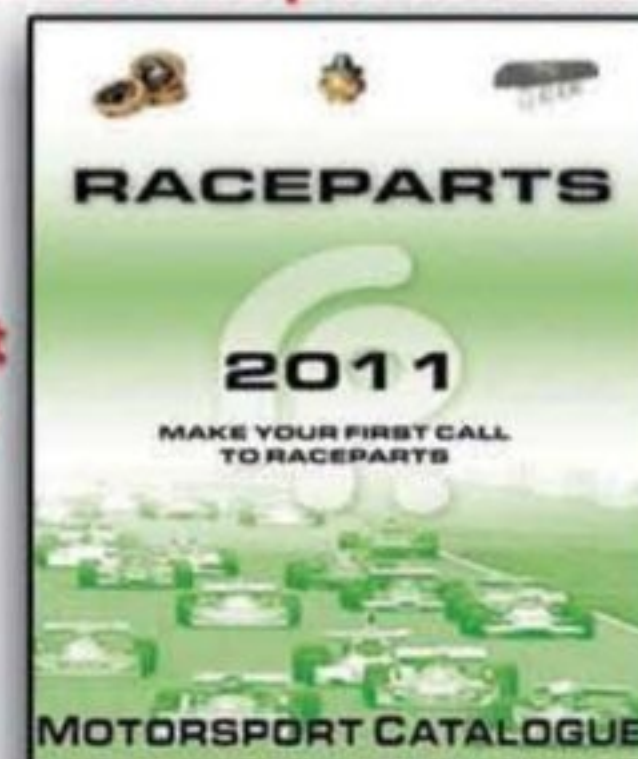

**New Year,  
New Products!**

**Tel: 01491 822000**



[www.raceparts-direct.com](http://www.raceparts-direct.com)



concept & design by racecar publicity management ltd.



metallurgy issue, a question of gains, lubrication and gaps. The turbo is heated to 1,000 degrees then when there is a corner and then it falls to 400. It is a hell of a shock. To overcome this is very difficult. When you thinking of the expansion it's incredible.'

These turbos have some clear advantages over conventional wastegate turbos especially in terms of lag and size. A big turbocharger can be very laggy, so only works well at higher engine speeds, whilst smaller ones have less lag but are not so good at higher speeds. A unit with VTG has the advantages of both. Some cars, like those in the WRC, use anti lag, but Baretzky dislikes the systems. 'Anti lag is a waste of energy,' he said. 'It is 30 year old technology. Thirty years ago we had no choice but now it's rubbish.'

**PRECISION MODULATION**

The advantages of the VTG, compared to the conventional system with wastegate, are not only in the quality of control and the associated possibilities of precision modulation. 'Dynamic behaviour, where proximity to the maximum boost pressure limit, stipulated by the regulations, is more precise,' added Baretzky. 'The big advantage is that they are variable, a bit like a stepless gearbox. You are always driving in an efficient and optimum area, so this gives a benefit in consumption and in back pressure because you can adjust it very accurately, as you have a mapping for that. In shifting and everything, you keep the boost up. The ACO even came to us at Spa, and looked at the data and said something is strange with your engine, we never see a drop in boost and we don't understand why. The reason for that is that it is a VG turbo.'

The design of the R15's turbo was tailored for the mass flow limited by the mandatory 37.9mm (reduced slightly in 2010) restrictor upstream of the compressor. Another design criterion was the boost pressure limitation stipulated by the regulations.

Exhaust temperatures, mass flow and control dynamics determined the design on the turbine-side. Neither Audi nor

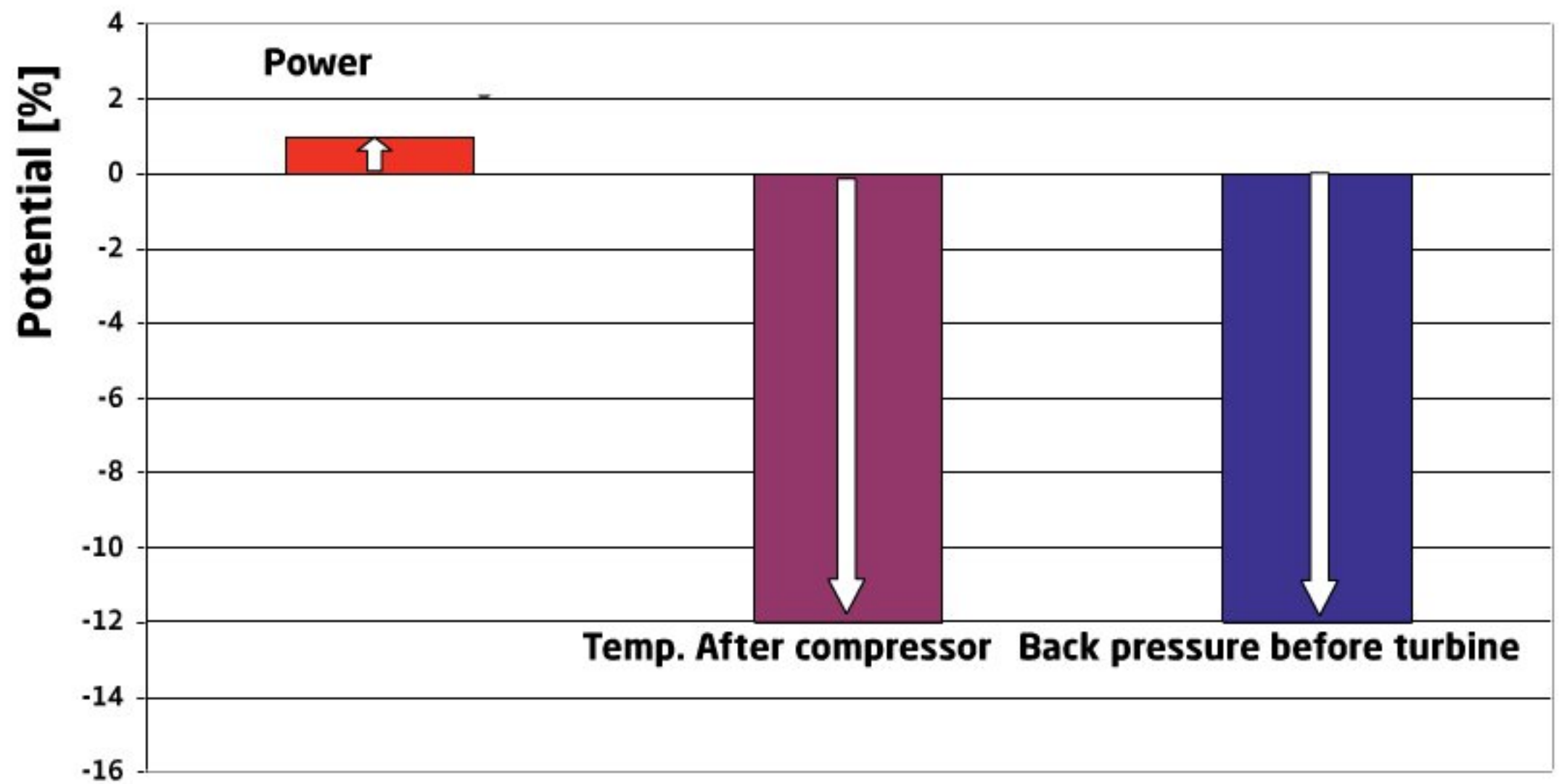

Compressor potential by optimised compressor impeller and housing

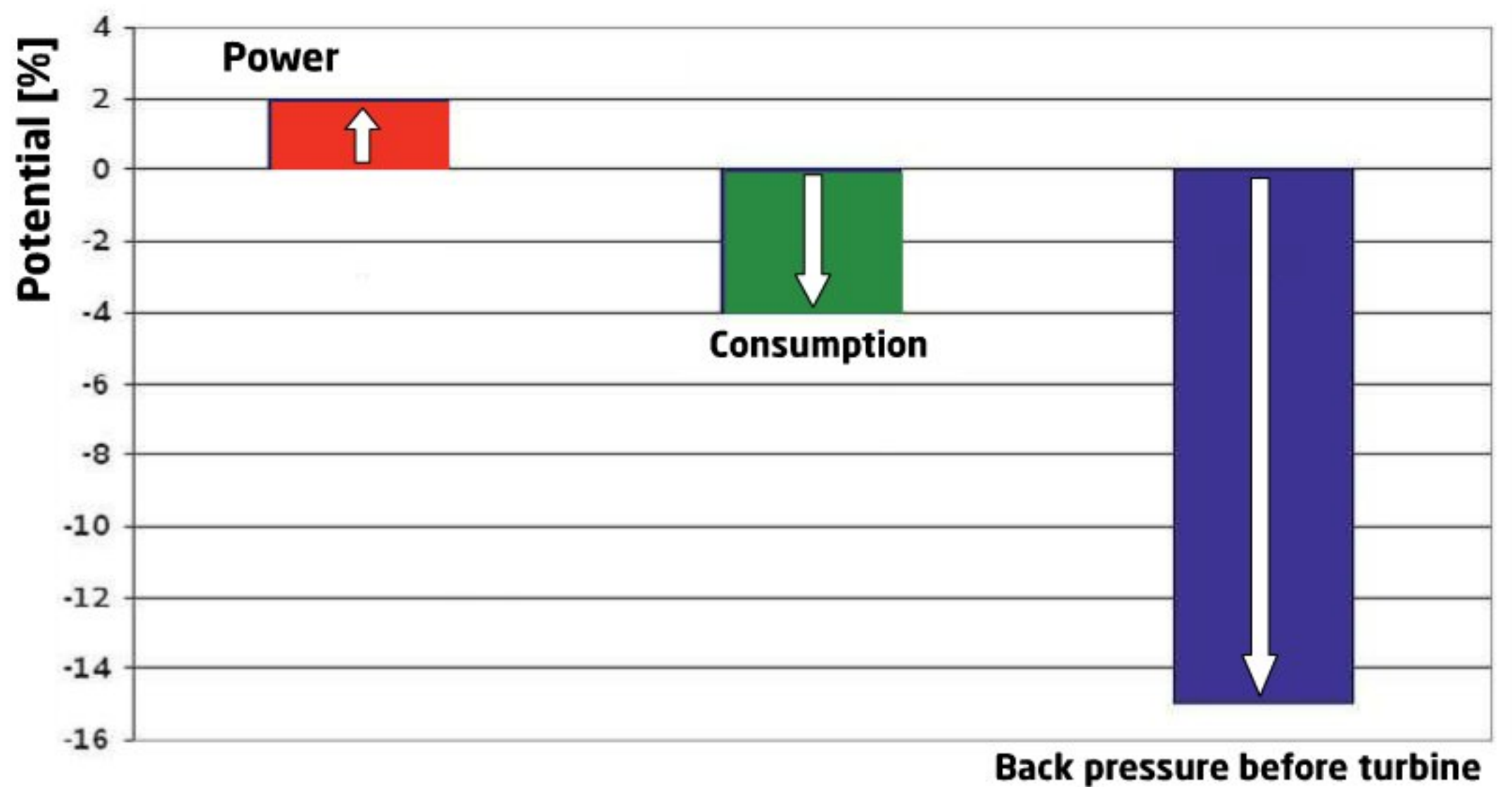

Potential VTG to wastegate exhaust turbocharger under static conditions

Honeywell is keen to detail specifics the blades and levers of the turbine, but the guide blades are made of high-temperature steel alloys. Controlling the single-sided bearing mount and set-up of component play was particularly critical. Blade control was made via a linear actuator

pressurised oil and drained by one stage of the dry sump scavenge pump. All elements are equipped with closure mechanisms allowing rapid replacement during races.

The greater efficiency of the VTG has a particularly advantageous effect on the

intake air temperature leads to an increase of the air mass and thus higher torque. However, in the restricted rev range a temperature reduction brings no further power increase since the maximum air mass is limited by the restrictor. Boost pressure drops in the restrictor range with constant air mass and decreasing charge air temperature. This can create more safety reserves in relation to boost pressure limits at higher ambient temperatures and the resulting higher charge air temperatures.

A drop in the charge air temperature after the compressor opens the possibility of reducing intercooler dimensions on the car, and thus reducing drag. 'A compromise must be found here between car performance, engine

**the charge air temperature was reduced by around 12%**

with very high adjustment speeds regulated by the engine control unit.

The turbocharger is mounted on ball bearings. The bearing housing is supplied with

charge air temperature after the compressor. On the R15 it was reduced by approximately 12%. In the case of constant charge air cooling in the unrestricted rev range, a reduction of the



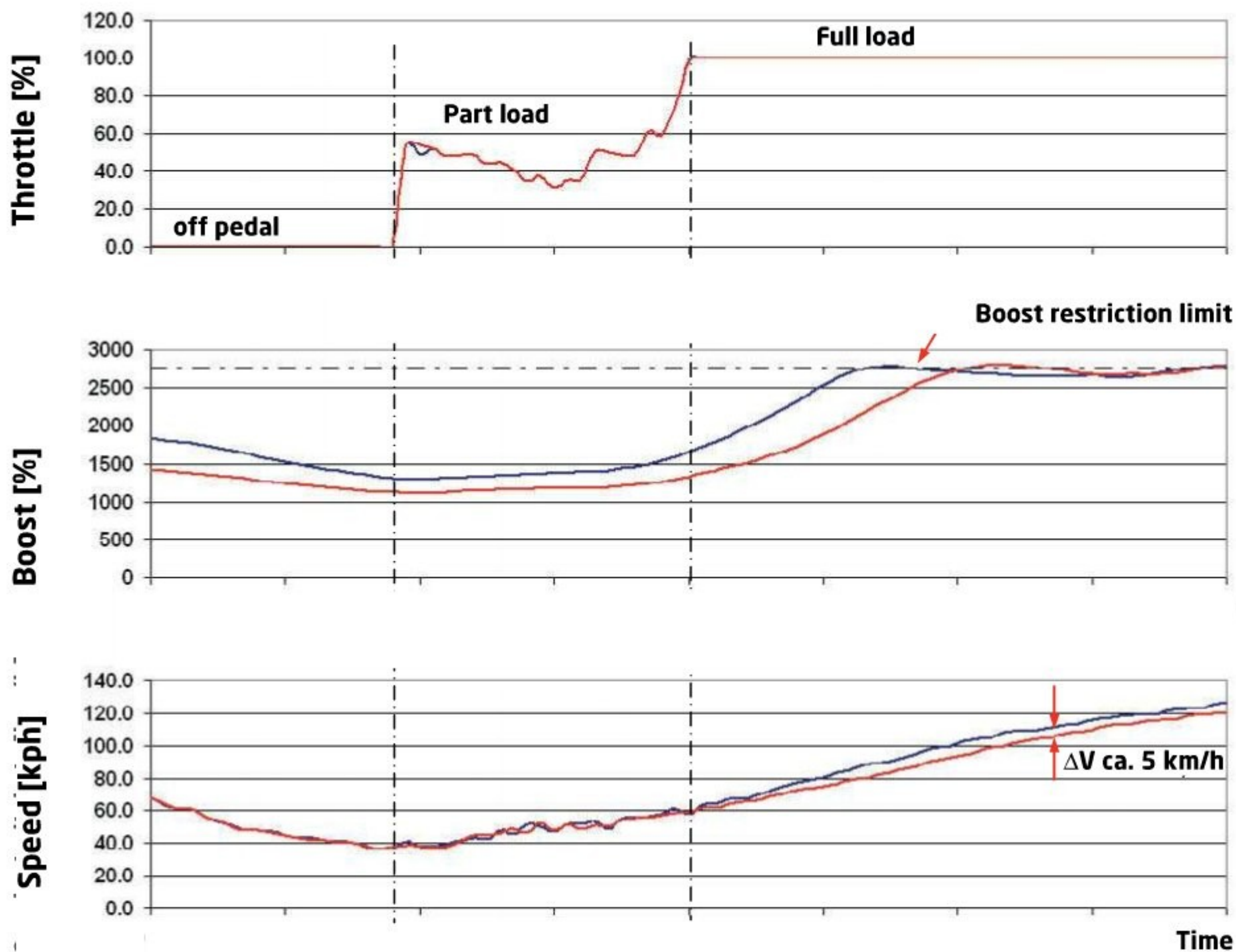

Owing to the precise and thus effective incident flow to the impeller wheel a comparatively high boost pressure level is also achievable in overrun conditions. In transient operation, the transition between overrun and full load, this leads to a significant improvement in response behaviour due to the rapid rise in boost pressure. The above table, which shows a comparison between the conventional exhaust turbocharger with wastegate and the VTG system, clearly illustrates this progress.

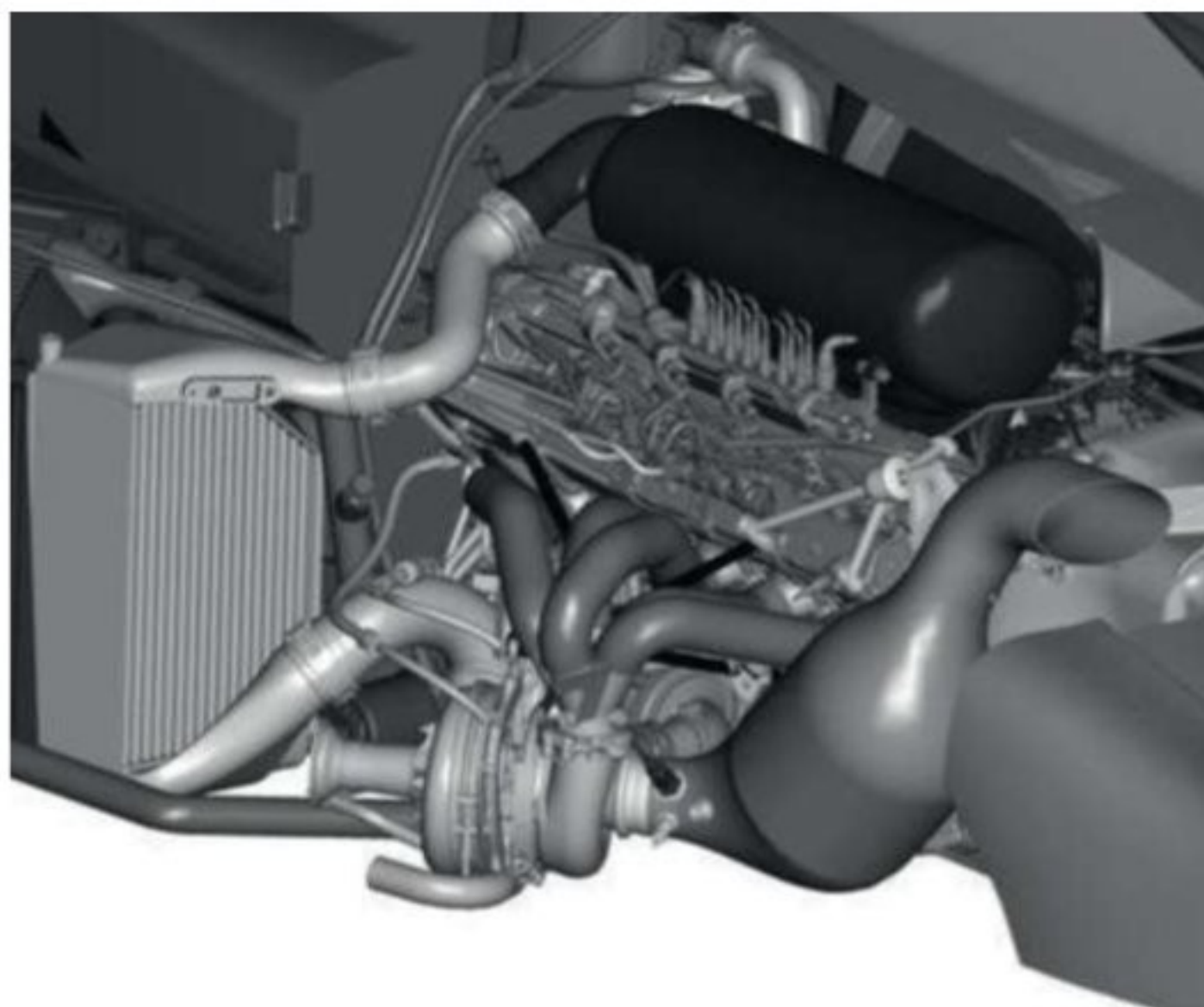

The turbocharger orientation was changed significantly compared to the R10. The turbochargers on the R15 are mounted considerably closer to the engine, the particulate filter is placed directly after the turbine exit and exhaust pipe exits were aimed upwards over the end portion of the rear cover. The reasons for this lay in the R15 package design, which specified a modified intake and exhaust air concept. Gas flow to the DPF located directly behind the turbine was optimised to guarantee uniform pressurisation of the particle filter.

torque and safety reserves in the event of possible intercooler blockage/fouling during a race,' explained Baretzky.

For the 2011 season Audi again launched an all new sports prototype, and again it was fitted with an all new engine, this time a V6 fitted with only one turbocharger. Honeywell had once again developed a new VTG unit for Audi and given them the edge over Peugeot. Whilst this technology is conventional on road cars the units used by Audi on its Le Mans races herald a technological breakthrough, and with F1 switching over to downsized turbo engines they too could follow sportscar racing's lead - but they will be playing catch up.

'F1 has refused to take VTG,' said Baretzky. 'I proposed it and they said no. I think they were worried we would come in with all our experience against the others who have none. Engineers

who have been working in F1 for as long as 20 years have never seen a turbo. So they know nothing about them and it's a clean sheet of paper. They are a bit worried so want to keep it simple at first, though I think it will come in future.'

One thing Formula 1 will introduce is turbo compounding, and here VTG could have some real benefits. 'Turbo compound layouts are electrically very clever, and this is really a road going thing,' says Baretzky. 'It could help people believe in, and understand, the capability of hybrids. This is a strategic point. Turbocharging and all the things around it are making a difference.' Audi has already revealed that the R18 was designed with the future installation of a hybrid system, and many believe it will be based on turbo compounding. All Baretzky would say is; 'lets see what the future holds.' 





The Titanium Specialists  
www.titanium.com



- BUY DIRECT
- AVAILABLE FROM STOCK
- TO YOUR SPECIFICATION
- AT COMPETITIVE PRICES
- ANY SIZE

Titanium Industries UK have extensive stock of Bar, Billet, Plate, Sheet, Wire, Tube and Pipe at their Midlands Centre for fast delivery throughout the UK.

The stock is certified to British, American and International specifications for Aerospace, Defence, Chemical Process Plant, Offshore and Down-hole Oil, Motorsport and Biomedical applications.

Titanium Industries UK have qualified metallurgists and engineers to advise on applications, specifications and processing techniques.

Titanium Industries UK are accredited to ISO 9001:2000, AS 9100 and customer approvals include BAE Systems, Westland SQA 50.



- STOCK**
- BAR
  - BILLET
  - BLOCK
  - GROUND BAR
  - PIPE & FITTINGS
  - PLATE
  - SHEET
  - STRIP
  - WELD WIRE

- SERVICES**
- BAND SAWING
  - GUILLOTINING
  - WATERJET CUTTING
  - FORGING

*Non-standard items can be produced or sourced on short lead times, so if you use titanium for any application, consult Titanium Industries first.*



Unit 38 Elmdon Trading Estate, Bickenhill Lane, Marston Green, Birmingham, B37 7HE  
Telephone: + 44 (0)121 782 9708 Email: uksales@titanium.com

[www.titanium.com](http://www.titanium.com)



LMP2 LE MANS 24 HOURS 2011  
**WINNERS**

Zytek Z11SN - 1st in LMP2 Class  
and 6 laps clear of it's nearest competitor



Thank you to Greaves Motorsport and all our suppliers in contributing to this outstanding achievement.

[zytekgroup.co.uk](http://zytekgroup.co.uk)

Zytek Engineering Limited, Main Street, Repton, Derbyshire DE65 6NZ, UK  
Tel: +44 (0) 1283 707 000 Fax: +44 (0) 1283 707 001 Email: motorsport@zytek.co.uk





# Under pressure

With the FIA trying to reduce engine capacity, the search is on for more power

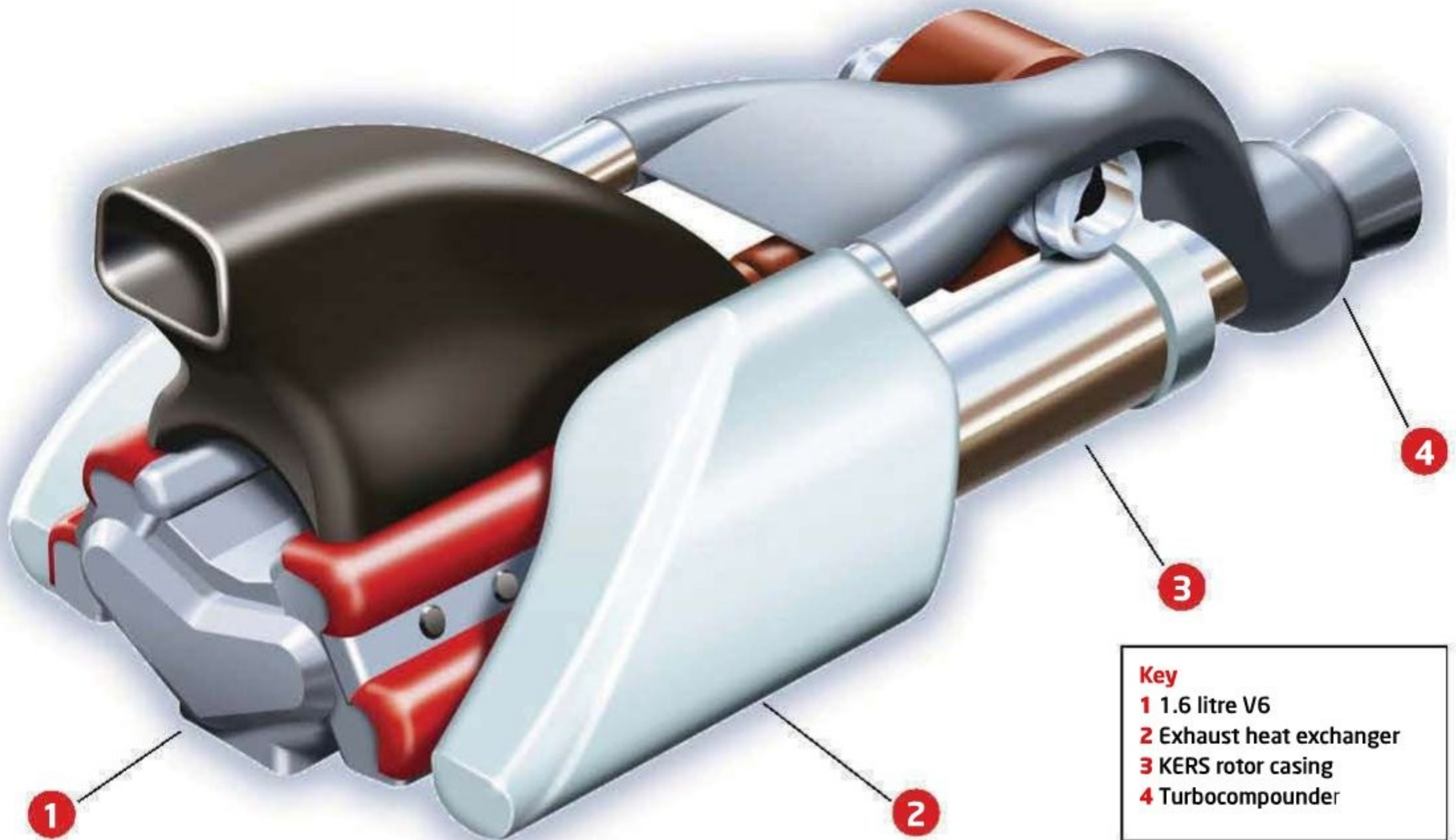

**Key**  
**1** 1.6 litre V6  
**2** Exhaust heat exchanger  
**3** KERS rotor casing  
**4** Turbocompounder

Since the 3.0 litre era ended, the FIA has been reducing the displacement of Formula 1 engines and employing stricter regulations in an effort to reduce development costs and limit the power output of the units.

In 2006 and 2007, the regulations pushed manufacturers towards a 2.4 litre 90 degree naturally aspirated V8 engine while allowing teams to run 2005 engines with a rev limit. In 2008, a limit of 19,000 rev/min was imposed and in 2010 this was reduced further, to 18,000 rev/min. Furthermore, a complete engine freeze has been implemented from 2008, stopping all development on engines for a period of 10 years.

This can only be contested

after five years, with the consent of all the teams. In recent years, there has been an incentive to promote a greener image of the sport to

mirror the movement of the automotive industry.

In 2009, KERS was implemented to recover braking energy, which is then used to increase the output of the engine. Proving to be a challenge for manufacturers, it was dropped in 2010 before being reintroduced in 2011. With the first five year term of the engine freeze coming to an end after the 2012 season the FIA, teams and engine manufacturers are in discussion to bring dramatic changes to the 2013 powertrain regulations. The aim is to increase the relevance of Formula 1 engines to road cars and increase the efficiency of the power train to showcase F1's environmental responsibility.

What is currently planned is to change the configuration to a straight four cylinder engine with

a maximum speed of 12,000 rev/min and reduce the displacement to 1.6 litres. KERS will remain part of the powertrain and it has been suggested that turbo compounding will make its debut in motorsport.

## TURBO COMPOUNDING

Turbo compounding is a term that is employed to describe a form of exhaust energy recovery that is used with internal combustion engines. It uses a turbine to recover energy from the exhaust gases, which are then used to increase the power output of the engine, hence the term turbo compounding, which means 'to combine with a turbine'. As an example, the simplest form of turbo compounding is presented in Figure 1.

After combustion, the burned gases are released from



**Racecar Engineering got its predictions almost correct way back in May 2007**



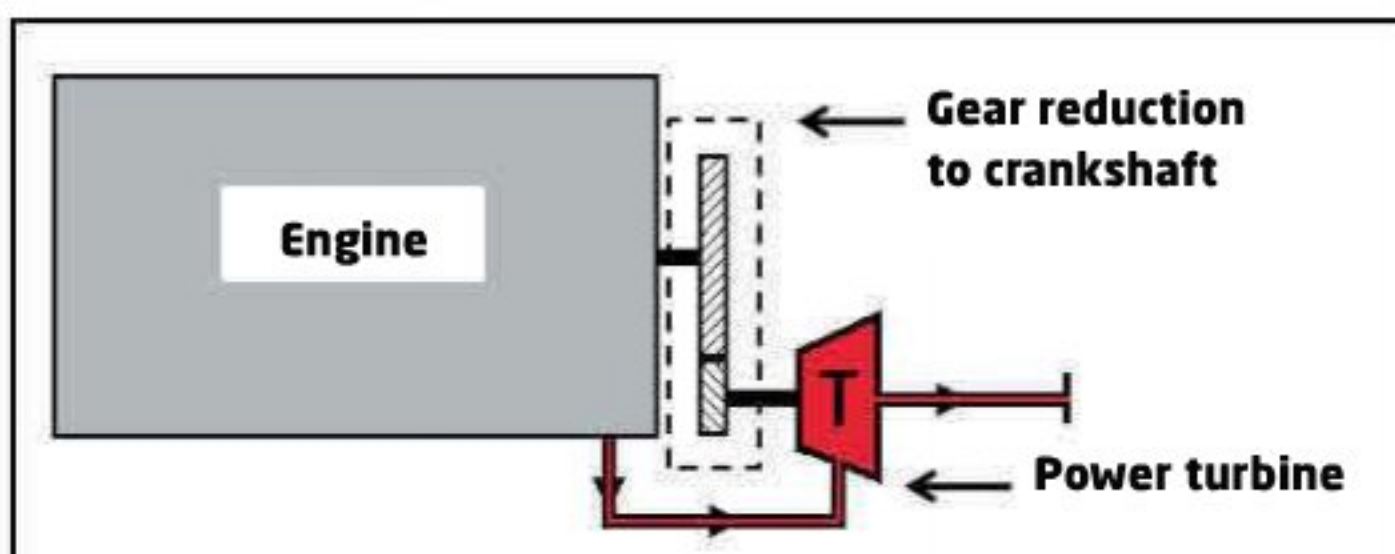

Figure 1: Basic turbocompounding

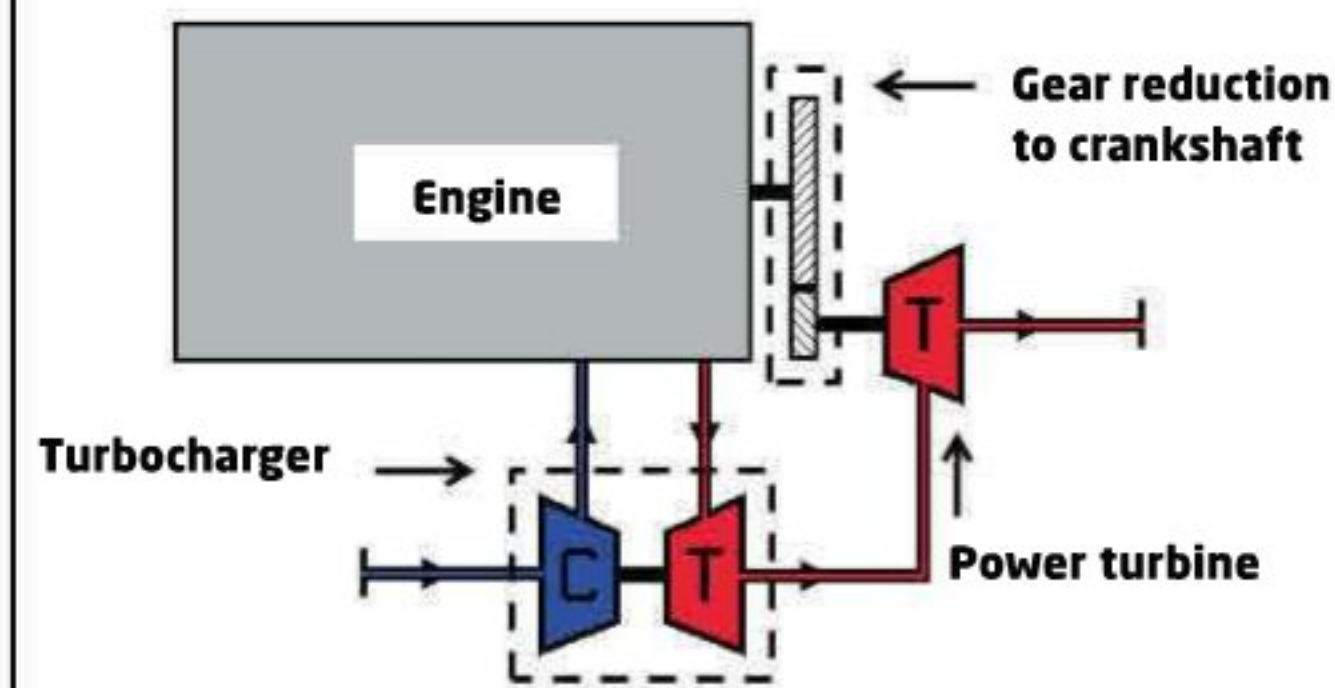

Figure 2: Turbocharged turbo compound layout

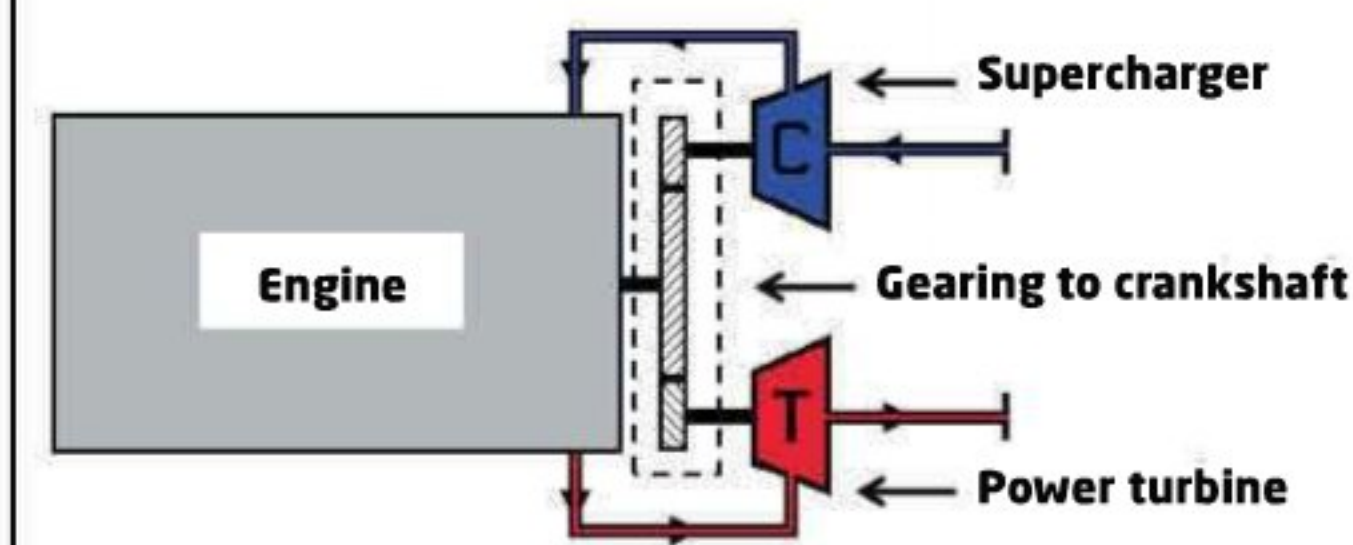

Figure 3: Supercharged turbo compound layout

the cylinders to the exhaust primaries at very high pressure, velocity and temperature. As they travel through the exhaust, they encounter the power turbine which acts as a blockage and causes the gas to build to a higher pressure which increases the pressure differential across the turbine (as the other end is at ambient pressure) and causes it to spin at many multiples of the engine speed.

The energy built up in the speed of the turbine is recovered from the energy contained in the exhaust gas. As a result, the gas will exit at the other end of the turbine at a much lower pressure and temperature. The energy of the turbine is then transmitted to the crankshaft through a gear reduction, which reduces rotational speed in favour of torque. This added

torque translates into an increase in engine power, which is the ultimate goal behind turbo compound layouts.

The configuration presented in Figure 1 is a simplified model used to describe the mechanism behind the technology. However, it is not a practical configuration because the back pressure built up by the gases before the turbine hinders the scavenging of the cylinders, which is detrimental to the performance of the engine. To overcome this, a higher charge pressure is needed which will force the burned gases out of the cylinders. Consequently, turbo compounding has to be combined with turbocharging or supercharging to be beneficial for an engine as is shown in Figure 2 and Figure 3 respectively.

Turbo compounding was first

used in the 1950s on aircraft engines. This technology was employed because radial aircraft engines were very inefficient. More than 50% of the energy input in the form of fuel mass flow ended up as lost energy in the exhaust. The most successful and documented engines were the Wright R-3350, the Napier Nomad and the Allison V-1710.

#### WRIGHT R-3350

The first mass produced turbo compound engine was a radial aircraft engine developed by the Curtis-Wright Corporation called the R-3350. It was a supercharged and turbo compound 18-cylinder engine with a displacement of 54.9 litres mainly used to power military aircraft such as the Lockheed P2V-7 and the Fairchild C-119. The turbo compound configuration of the engine is shown in Figure 4.

The burned gases are released through the exhaust system and directed towards the turbine. The power produced by the turbine is mechanically linked to the crankshaft through two gear reductions and a fluid coupling. The turbine is first connected to a set of bevel gears, which provide a first gear reduction. The bevel gear is then connected to the fluid coupling that is connected to the crankshaft through a pinion providing a second gear reduction resulting in a total ratio of 6.52:1.

The role of the fluid coupling is essential in providing a mechanical link between the crankshaft and the turbine. It absorbs the vibrations of the turbine caused by the irregular flow of exhaust gases and it dampens the inertia loads of the crankshaft created during gear changes. Hence it allows a smooth transmission of the power from the turbine to the crankshaft. There are of course losses incurred by the slippage in the fluid coupling but they are very small, in the range of one to two percent of the energy recovered by the turbine.

In cruise condition, the rate of fuel injected into the cylinders equates to a power of 5,650 hp. This is calculated by multiplying the mass flow rate of the fuel (kg/s) by the lower heating value

(energy contained per unit mass kJ/kg), which gives a result in kilowatts. This is then multiplied by the conversion ratio of 1.34 to obtain the result in horsepower. Out of that total energy, 1,680 hp (29.7%) is converted into engine power and 2,915 hp (51.6%) is released in the exhaust gases. The remaining 1,055 hp (18.7%) consists of mechanical, thermal and supercharger losses. Out of the 2,915 hp released into the exhaust, 920 hp is contained in the kinetic energy of the gases, which is the recoverable portion of the energy. The turbine generates 195 hp, which is 21%

**The added torque translates into an increase in engine power**

of the kinetic energy. However, 35 hp is lost in the mechanical linkage resulting in a net power recovery of 160hp which translates in a 9.5% increase in total engine power.

#### NAPIER NOMAD

The Napier Nomad is also a noteworthy compounded engine that was developed by D. Napier & Son Limited over a period of seven years starting in 1947. It is a two-stroke 12-cylinder diesel engine that was aimed at aircraft used for air transport services and was built with the objective of having the best possible fuel economy. Napier opted for a two stroke mainly because there is no risk of detonation, allowing high compression ratios across the compressor, which minimizes the effect of backpressure created by the turbine.

The system works like a conventional turbocharger where the exhaust gases released from the cylinders spin the turbine, which in turn spins the compressor that increases the charge air density and boosts the engine's output. The main



## DESIGN AND INNOVATION

difference is a mechanical linkage between the turbocharger shaft and the crankshaft.

In cruise condition, the turbine will always recover more energy than is needed to spin the compressor and achieve the required pressure ratio. This additional energy is transmitted through the mechanical linkage to the crankshaft. The linkage used is an infinitely variable gear (IVG), which maximizes

the efficiency of the system at every speed.

At cruising altitude, the engine produces 2,500 hp. The power recovered from the exhaust by the turbine is also equal to 2,500 hp. However, 1900 hp is used to drive the compressor leaving 600 hp that is transmitted to the crankshaft. This results in a 24% increase of net power output for a total of 3,100 hp.

### ALLISON V-1710-E27

The Allison V-1710 was a military aircraft engine designed for the US army and used during World War II on fighters such as the Lockheed P-38 and the P-51 Mustang. It was a 60-degree V-12 with a displacement of 28 litres. In 1944, Allison decided to continue developing the engine in an attempt to increase its output through the use of an exhaust turbine that is directly

connected to the crankshaft. The main requirement for the military was to have more power at sea level, in order to be able to take-off with heavy fuel loads, and at altitude in order to increase top speed. As a result, the V-1710-E27, a turbocompounded version of the original engine was born.

The system used is an elaborate two-stage supercharged turbo compound. The exhaust gases drive the turbine, which in turn drives the first stage supercharger. Excess energy is then sent to the crankshaft through fixed ratio gearing. A second stage supercharger is powered by the crankshaft to further increase the pressure of the charge.

In cruise conditions, at 9,144 metres and 3,200 rev/min, the engine produced 1,530 hp with the turbine contributing 550 hp to that output. An original V-1710 produces 1,200 bhp in the same conditions, which shows a 27.5% increase in power for the compounded V-1710-E27 model. Despite this improvement in performance, only one engine was built and the project was dropped to make way for the more efficient turboprop engine.



Radial aircraft engines were the first application for turbocompounding

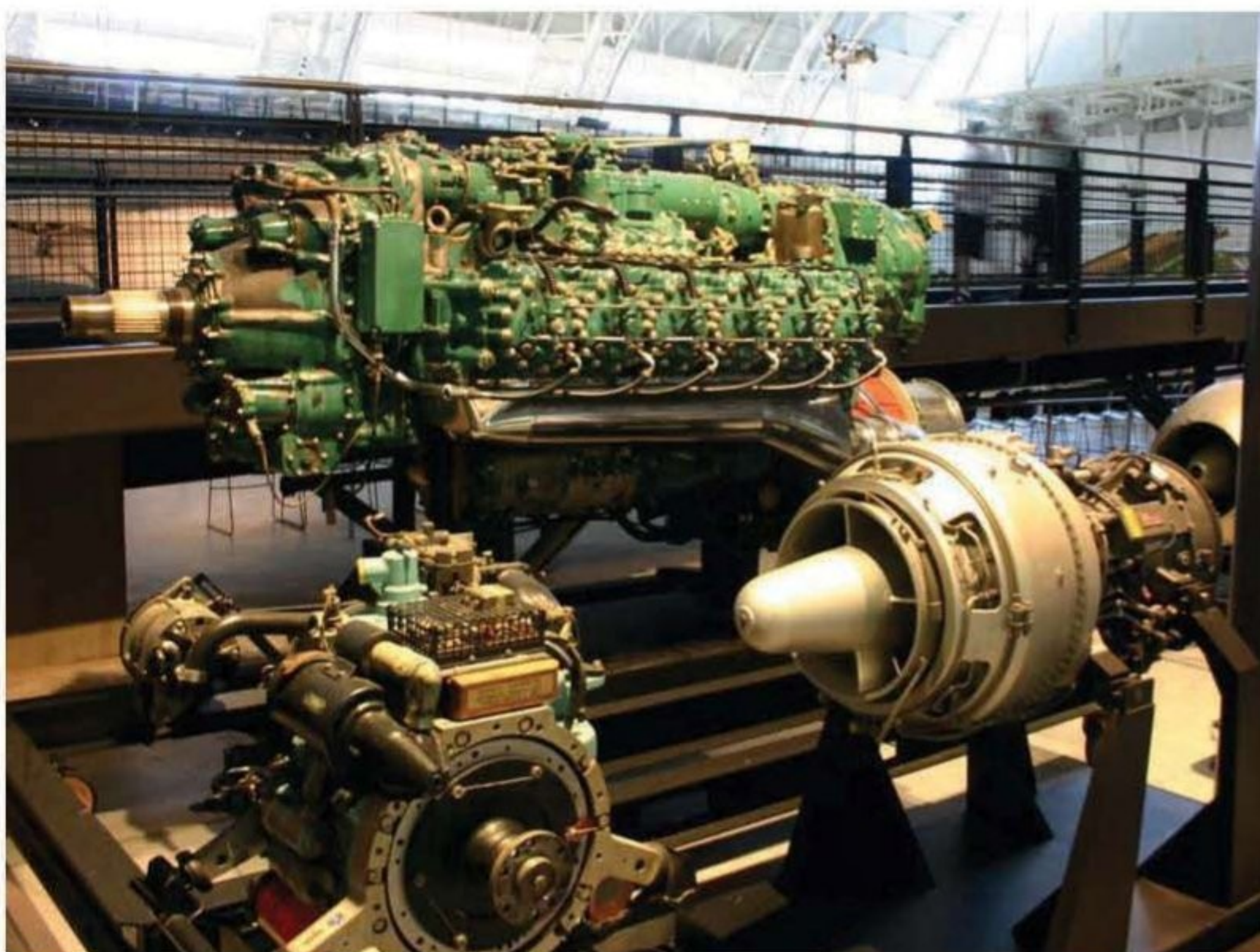

The Napier Nomad engine was a highly complex turbocompounded two stroke diesel

### STATE OF THE ART

Today, turbo compounding is mainly used on large displacement diesel engines designed for use in heavy ground vehicles such as trucks and agricultural equipment. In contrast with the aerospace industry's thirst for power, the automotive manufacturers implemented the technology to reduce fuel consumption. Two manufacturers are noteworthy for their intricate systems, Cummins and Caterpillar.

Cummins was the pioneer in automotive turbocompound technology. In the 1970s it implemented turbo compounding on the NTC-400, a turbocharged six-cylinder diesel engine with a displacement of 14 litres, designed for Class 8 trucks, which is the U.S. classification for vehicles above 15,000 kg.

The system is very simple and is split into three main modules. Module 1 consists of a radial turbine that is powered





# WE MAKE, YOU RACE!

## WINDFORM ADDITIVE MFG:

CAR AERODYNAMIC FEATURES  
CAR BRAKE DUCTS  
WIND TUNNEL PARTS  
MOCKUP PARTS

## WINDFORM ADDITIVE MFG:

ELECTRIC COVERS AND SPECIAL PIPES  
INTAKE MANIFOLDS

## MECHANICS:

UPRIGHTS/SPINDLES  
ROCKER ARMS  
SUSPENSIONS END FITTINGS

## MECHANICS:

SPECIAL SPLINED EDM PARTS  
GEARBOX  
ENGINE PARTS  
COMPLEX 5X CNC MACHINED PARTS

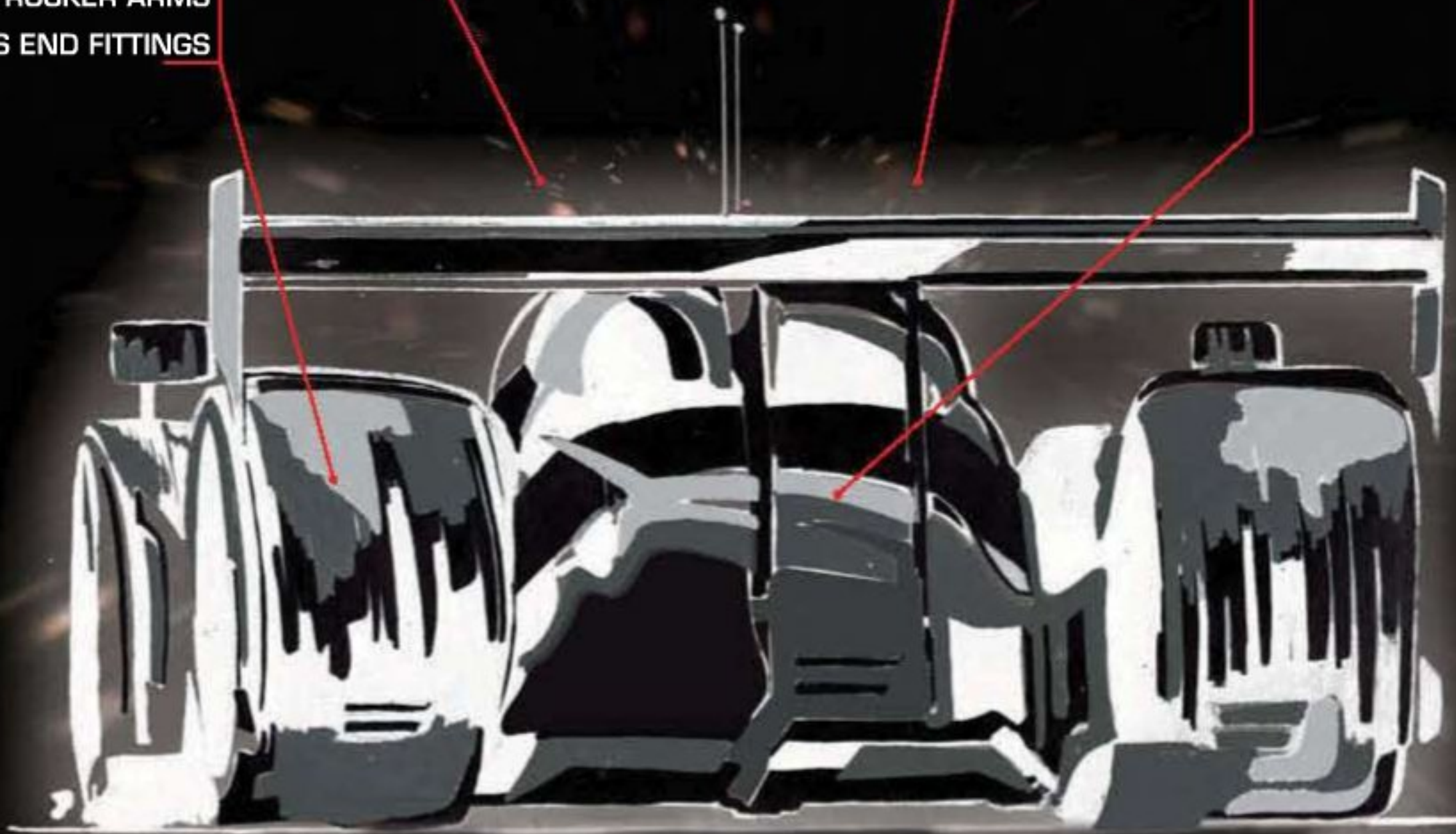

## OTHER WINDFORM ADDITIVE MFG:

MOULD INSERTS  
MASTER MODELS  
SPECIAL JIGS

AT 300 KM/H, QUALITY ISN'T OPTIONAL, IT'S YOUR LIFE!

[www.crp.eu](http://www.crp.eu)

[www.crp-usa.net](http://www.crp-usa.net)



[info@crp.eu](mailto:info@crp.eu)

[info@crp-usa.net](mailto:info@crp-usa.net)

HS CNC MACHINING . ADDITIVE MANUFACTURING . RAPID CASTING . ENGINEERING & REVERSE ENGINEERING  
C.R.P. Group · Via Cesare Della Chiesa 21 · 41126 MODENA · ITALY · Phone +39 059 821135 · Fax +39 059 822071





## SHELL RACING SOLUTIONS

### Bringing Technology Together.

#### Supply

In-house production and global reach of specific and reliable fluids

#### Technology

Product development and technical support for cutting-edge technologies

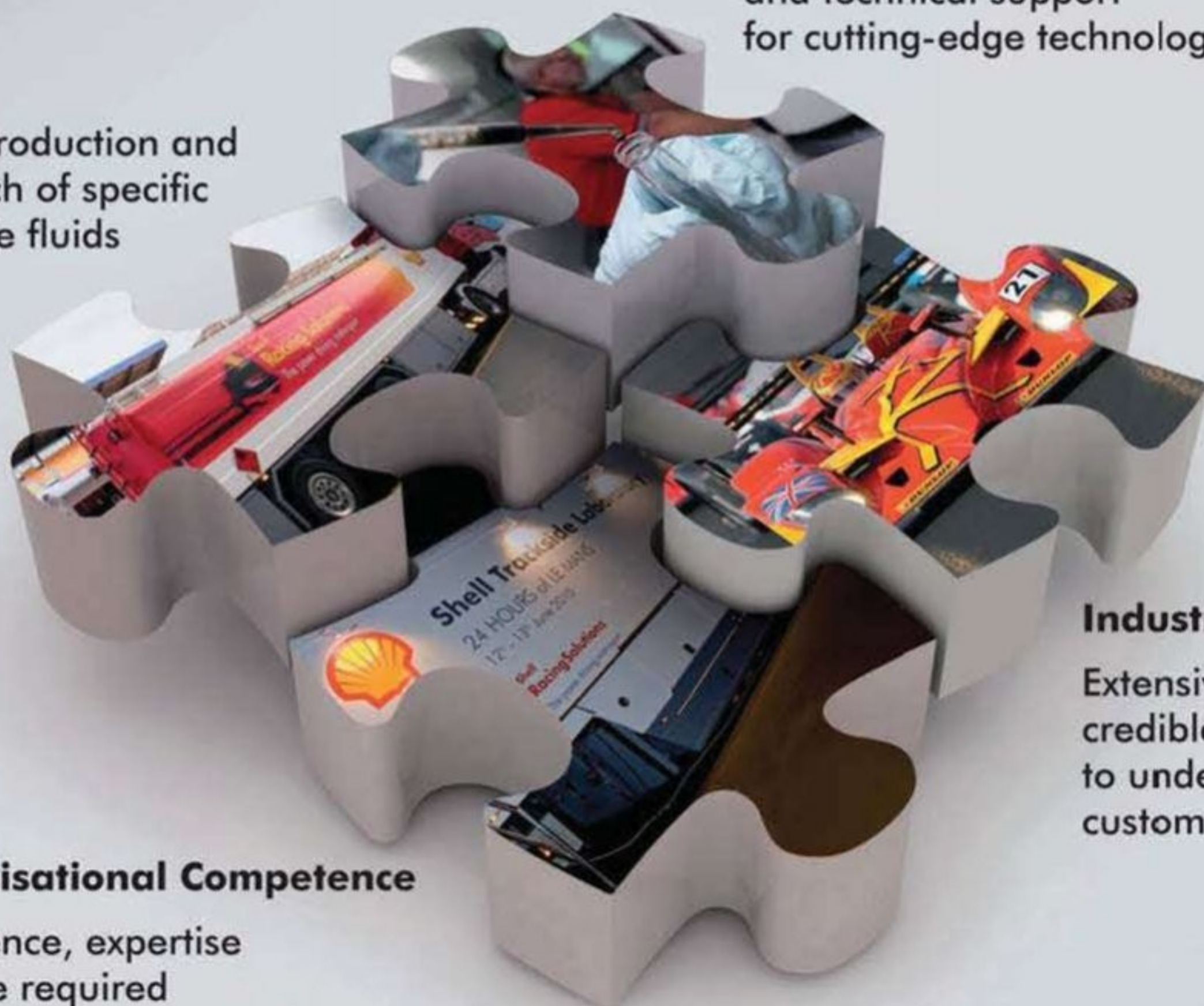

#### Industry Knowledge

Extensive network and credible partnerships to understand the customers' needs

#### Organisational Competence

Experience, expertise and the required speed of response

## Race Fuels. Race Lubricants.

Exclusive UK distributors

One-Fuel Ltd.

Unit 1, Control Tower

Wolverhampton Business Airport

Bobbington, South Staffs

DY7 5DY.

T:01384 90 40 31

E:sales@onefuel.co.uk

[www.shellracingsolutions.co.uk](http://www.shellracingsolutions.co.uk)





by the exhaust gases. Module 2 is a fixed ratio gear reduction and Module 3 consists of the fluid coupling and the final gear reduction. The fluid coupling fulfils the same essential function of damping the inherent torsional vibrations as in the Wright R-3350.

The turbo compound engine produced 450hp, which represented a 50hp increase over the original engine. This allowed the NTC-400 to reach the same power as the original engine while running 200 rev/min slower. This translated into a reduction of fuel consumption of 24.3 to 30.4 g/kW.h throughout the operating range.

**CATERPILLAR**

More recently, Caterpillar developed an electric turbo compound system for the

same class of vehicles that the Cummins NTC-400 was targeting. The system uses an innovative setup shown in Figure 4.

The electric turbo compound differs from the conventional turbo compound in that there is no power turbine. It employs the same principle used by the Napier Nomad, relying on the excess power generated by the turbocharger turbine.

In this case, the power is not mechanically transmitted to the crankshaft. Instead, a motor generator converts it to electrical power for storage in a battery. The stored energy can then be used to power the ancillaries, drive a motor geared to the crankshaft or be sent back to the motor generator to assist the turbocharger in case the turbine does not have enough power to

spin the compressor at the required speed to achieve the required pressure ratio. Simulations on the C-15 truck engine showed a 5 to 10% decrease in fuel consumption.

It is systems such as this with an electric component in the turbocompound system which shows the path for future motorsport applications such as the one detailed here.

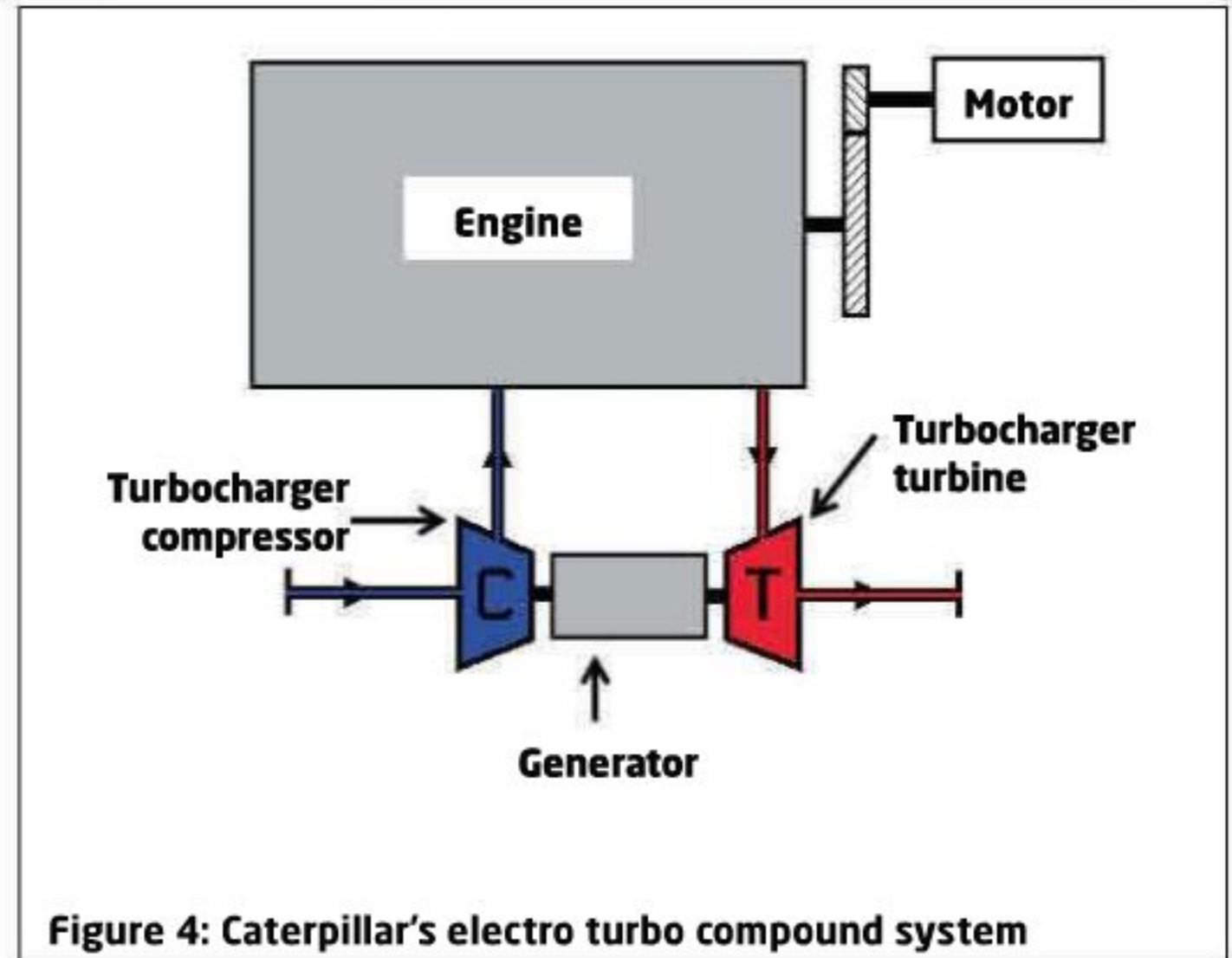
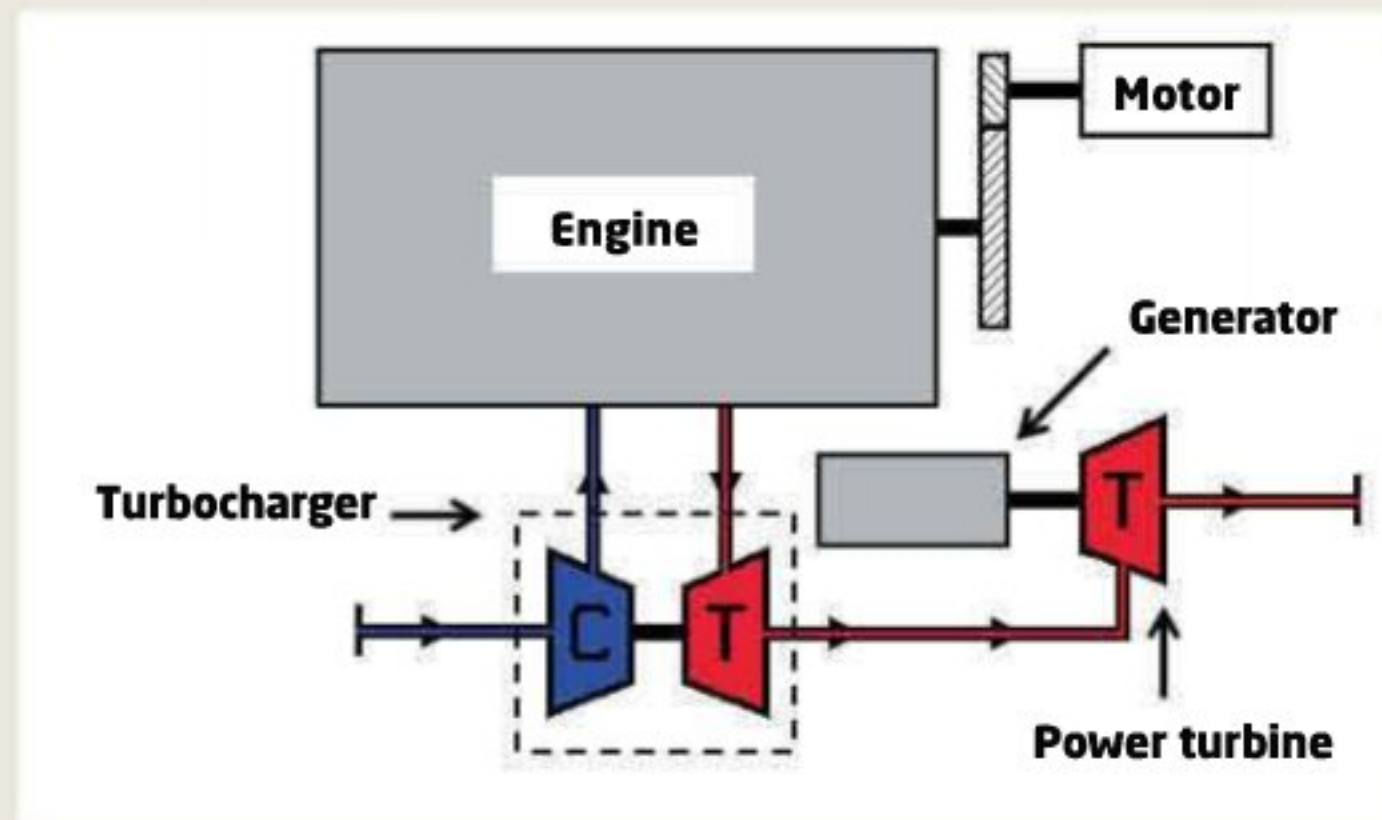

**Figure 4: Caterpillar's electro turbo compound system**

**APPLICATION FOR AN F1 ENGINE**

The power train arrangement is similar to a conventional turbocharged turbocompound engine described earlier with the exception of the power transmission mechanism. There is no mechanical link between the turbine and the crank shaft. Instead, a generator is employed to convert the power recovered by the turbine to electricity. This is where the Kinetic Energy Recovery System (KERS) plays an important role. Its battery and motor generator are used by the turbo compound system as well. The recovered electricity is stored in the KERS battery and then can be used at a later point to power the KERS motor generator adding torque to the crank shaft and hence increasing the power output of the engine.

Another aspect that may differ in an F1 engine from conventional turbo compound engines is the power turbine. Radial turbines are more generally used as power turbines because they are already mass produced for the turbocharger and supercharger markets and therefore are cheaper to implement. However they require a high pressure differential in the exhaust which creates unwanted



<b>Table 1: The original engine proposal</b>	
Configuration	Straight 4 (I4)
Displacement	1.6 litres
Speed	Limited to 12,000rpm
Bore	82mm
Stroke	75.74mm
Fuel Consumption	Limited to ~26g/s
Aspiration	Turbocharged
Energy Recovery	KERS & turbo compound

back pressure on the engine. Axial turbines are rarely used for this scale of applications and require a more significant investment in terms of research and development. It should be considered that they rely more on the velocity of the flow and hence require a lower pressure differential resulting in less backpressure on the engine.

In F1, efficiency being

paramount and financial resources not being an obstacle, an axial turbine would be more appropriate.

Simulations done by the author at Cranfield University and supported by Cosworth have shown that turbo compounding can significantly increase the power output of the engine for no additional fuel consumption which is very important because

the fuel mass flow is expected to be limited. The 2013 F1 engine was simulated in AVL Boost with slightly modified parameters such as a speed limit of 10,000 rev/min, a fuel mass flow limit of 25 g/s and a fixed gear mechanical link between the crank shaft and the power turbine. The engine produced 432.5 kW at 8,500 rev/min with 31.5 kW being attributed to turbo compounding. This represents a significant 7.3% increase in power over the turbocharged engine for the same fuel mass flow and translates into an increase in thermal efficiency from 36.95% to 39%, which is a significant leap forward.

Turbo compounding can be beneficial to Formula 1. Not only will it help promote a greener image to the sport by significantly increasing the efficiency of the power train, but it will also re-affirm F1's position as the pioneer in vehicle technology by being the first to showcase the potential of turbo compounding to the automotive industry. The exact specification of the new engines is yet to be revealed but it will be a 1.6 litre turbocompound V6, and they will likely appear in 2014.



# A golden year - despite Englebert

How the spirit of a legendary Ferrari was recreated and returned to the racetrack

**E**ngelbert Humperdinck had two number one singles in 1967; Release Me and The Last Waltz. Also in the charts were the Beatles, the Monkees and Petula Clark. It was a different time to today, not only in music terms, but also in the automotive industry. For James Glickenhaus, a former film director, producer and actor and now Wall Street investor, this was a golden year for car

manufacture, and he has in his collection no fewer than six cars from that year.

The most significant of those is the 1967 Ferrari P3/4 which the American used as a base model for Pininfarina's creation, the P4/5. First revealed at Pebble Beach in 2006, it was a stunning redevelopment of the last Ferrari Enzo sold, with styling and engineering from famed coach builders Pininfarina.

Pininfarina's styling team leader, Ken Okuyama, said that the firm 'wanted to stay away from retro design and move towards a more forward thinking supercar.' Ferrari President Luca di Montezemolo loved the car so much he allowed the project to use the official Ferrari badge. However, even he shied away when Glickenhaus decided to develop a racing car in a similar vein.

'The Enzo had a carbon fibre tub, a V12 engine that was not fuel efficient, and also it was not an homologated car,' said Glickenhaus at the Nürburgring 24 hours in June. So, with N-Technology, and help from Paolo Garella, former Head of Special Projects at Pininfarina, a new concept was derived.

Glickenhaus wanted a road legal car that he could also race, in the spirit of the 1960s, but





needed a series that would accommodate him. He found one in the organising body of the VLN, who agreed to his principal and gave him the racing platform.

He bought a Ferrari 430 road car for the tub, and road homologation, and also bought a Ferrari GT2 racecar for the engine and transmission. He married the two, and then fitted a carbon fibre body over the top of it to produce an outlandish design.

'The road car is wider at the back, so we made it square,' said Glickenhaus. 'We narrowed the back to make it two metres wide, which involved redesigning the suspension and drive shafts. We took the roof off the road car, we built the roll cage out of steel to meet with FIA safety standards, and then in CAD/CAM we did all the other systems.'

The P4/5 Competizione retained the road-homologated lights from the P4/5 by Pininfarina, but otherwise was

completely new. The company developed the four litre V8 engine slightly, working on the pistons and connecting rods to make the engine higher revving and more fuel efficient to be competitive at the 'Ring. Base weight of the car is 1200kg.

There are no plans to integrate a new F458 engine,

efficiency is very important because at the 'Ring if you can go seven, eight or nine laps it makes a difference.'

The racecar is road legal, and raced at the Nürburgring with New York licence plates, having passed the pollution and crash testing procedures.

'As a crash test as an

**“ In the 1960's you could buy a car, tape the headlights and go racing, it was very different ”**

with a direct injection engine, despite the need to complete nine laps of the 25km Nordschleife on a tank of fuel to be competitive. 'There is nothing inherent in the 458, except the direct injection, that would make it more efficient,' said Glickenhaus. 'If we had less restriction on the aero we could make enough horsepower. Fuel

individual you are allowed to do it on the computer,' said Glickenhaus. 'We are running catalytic converters and mufflers and because this is not a commercial venture, I am not selling the cars, they cut you a little more slack.'

Ferrari was clearly not that worried about the Competizione as it sent Mika

Salo and Nicola Larini to the 24 hour race to join former FIA GT Champion Luca Cappellari and multiple touring car champion Fabrizio Giovanardi in the car, racing under the Scuderia Cameron Glickenhaus name. Victory was hardly likely, even in its E1 XP2 class. It was up against the factory BMW Schnitzer squad, racing the 1300kg M3, and despite problems, the BMWs finished second and 26th overall, while the Ferrari finished third in class, 40th overall.

'You have Porsche, BMW, Mercedes and Toyota and a bunch of guys who go out and buy a BMW, stick in a roll cage and go racing,' said Glickenhaus, now a firm lover of the Nürburgring 24. 'In the 1960s you could buy a car, tape the headlights and go racing. Today road cars are not racecars. In 1967 or earlier, you had very different motor vehicles.' This is as close as he could get. 





# HOW TO BUILD A F1 CAR WITHIN FIVE MONTHS

On Pole at Lotus Racing.



Visit [www.capricorngroup.net](http://www.capricorngroup.net) for the complete story.

 **capricorn**  
A U T O M O T I V E



# Forward thinking

Thwarted by a lack of budget and development time, the March 711 paid the price for being aerodynamically ahead of its time



BY ALAN LIS

Current Formula 1 chassis designs may seem, to the outsider at least, to differ only in their livery, so a look back at the cars that raced in F1 in the early 1970s is an eye-opening exercise. A prime example of the diversity of approaches in use at that time is the 1971 March 711 which, even 40 years after its introduction, remains startling and instantly recognisable.

The March 711 broke new ground with its aerodynamic configuration. Pre-eminent automotive aerodynamicist Frank Costin was consulted on this during the design phase. Starting in the 1950s, Costin established his reputation through his work with Vanwall in Formula 1, and the likes of Lister, Lotus and Maserati in sportscar racing. By the time he was contacted by March, he had also designed and built cars in his own right

as the 'Cos' in Marcos, and had produced the radical Protos Formula 2 racecar in 1967, which featured a plywood chassis and all-enveloping bodywork.

On the March 711, Costin's role was the design of the wings and the shape of the monocoque and bodywork. 'I went up to see Frank in his workshop near Caernarvon castle and we talked about the car as I envisaged it,' recalls March Engineering chief designer Robin Herd.

'While low drag was definitely a target, it wouldn't be true to say that it was more of a priority than downforce. It was really a combination of the two. The 711 front wing was pretty damn big and we had a decent sized rear wing too, so there was plenty of downforce available.'

When the March 711 was unveiled to the press it caused a sensation. Breaking with the F1 fashion of the time, the car was clothed in bodywork from





Much of the 711s rear bodywork was discarded when engine cooling problems arose during initial track testing.

the tip of its bulbous nose to the rear of its Cosworth DFV engine. Its side-mounted coolers were cowled and the driver was protected by a cockpit surround that one writer at the time described as looking like the conning tower on a submarine.

The most startling feature of the 711, however, was a full width elliptical front wing mounted on a central strut rising from the nose. According to Herd, the front wing was Costin's idea, although the March man had been thinking of a similar aerodynamic concept already (see photo caption P73).

#### **MEDIA INTEREST**

Having created a lot of media interest at its launch, the March 711 ran into trouble almost immediately. During the first meaningful tests in the high

designed special combined oil and water radiators, but early testing proved that they weren't big enough, and by that time we couldn't afford to design and make new ones. We had spent all the available budget, aside from the £10,000 we had left to run Ronnie [Peterson] for the season.'

The addition of larger, separate water radiators brought the engine water temperature under control, while separate oil coolers mounted beneath the rear wing did a similar job for the engine lubricants, but at the cost of a change in weight distribution and a compromise to the car's original aerodynamic concept.

In addition to the cooling problems, the 711's original engine cover design, with NACA ducts recessed into it, was found to be deficient in its ability to feed enough air to the engine

low-mounted side air inlets, as in the Costin re-design, but at the Mexican Grand Prix the works Matra team took this burgeoning area of development a step further by fitting its cars with a glass fibre engine cover / air scoop. This collected air from above the rollover bar, although it was not fully sealed onto the engine inlet trumpets, and was therefore less effective than it might have been.

Following Matra's lead, and working on the basis that the airbox was part of the engine rather than the car's bodywork (the height of which was limited), Tyrrell designer Derek Gardner came up with a properly sealed air collector box with its inlet positioned above the roll hoop, where it was able to ingest a stream of far less turbulent air than that collected by the Costin design. With this deemed legal, March and every other F1 team was effectively obliged to follow the Tyrrell lead, but otherwise the 711s ran with their rear ends unclothed for the remainder of the season.

#### **FALTERING START**

The new March's racing career had a faltering start, too. At the South African Grand Prix, team leader Peterson was the best placed of the three 711s that took part, and finished 10th, but was unable to pass one of



the previous year's 701s, now in private hands, on Kyalami's long main straight. Then a brake shaft failure at the non-points Race of Champions led to all 711s having their inboard front brake discs moved outboard onto the uprights, further compromising weight distribution and handling.

It was not until the Monaco Grand Prix, the third round of the 1971 Formula 1 World Championship, that the 711's season finally took off. With an updated rear suspension, Peterson started from eighth on the grid, vaulted up to fifth on the opening lap and brought his car home in second place, beaten only by Jackie Stewart's Tyrrell. A few races later, Peterson excelled at the British Grand Prix, qualifying fifth and finishing second again behind Stewart.

The Austrian Grand Prix on the fast-flowing Österreichring circuit threw up another problem. Peterson struggled home to an uncompetitive eighth place finish, while F1 debutant, Niki Lauda, was slowest of all in qualifying, and pulled out of the race with handling problems

**“ The most startling feature was a full width elliptical front wing ”**

ambient temperatures and high altitude of the Kyalami circuit in South Africa, the 711 overheated, so the engine cover and radiator cowlings were removed. 'There was a slight miscalculation by Frank and me on the cooling system,' says Herd. 'Initially, we'd

beneath it. Costin came up with an alternative design with protruding side inlets that cured the problem but, before it was introduced, the rival Tyrrell team effectively moved the goalposts.

During 1970, Team Lotus had used an engine cover with





The March 711 raced on into 1972 with the independent Williams team, which ran it with a more conventional nose and a single element rear wing

before half distance.

'If the front wing was tipped up too far, the downforce disappeared,' explains Herd. 'The 711 didn't work very well on circuits with long, fast corners, and the absolute killer was the Österreichring. At that track we were really stuck in a downward spiral. In a fast corner the aerodynamics are significant and the downforce generated at the front of the car is about 40 per cent. The driver accelerates as soon as he can and as the nose of the car lifts under acceleration, it reduces the downforce so the car tends to develop an aerodynamic understeer. You can live with that for a while on normal circuits, but on tracks with long, fast corners it tended to overload the front tyres because of the understeer. At the Österreichring the drivers found that it was okay for a few laps but it would eventually get to the point where the tyres would not be able to recover before the next corner.'

The 711 ought to have been perfectly suited to the high-speed straights and corners of Monza, the venue for the Italian



End plates are fixed to several of the wings in current Formula 1 use. Their purpose is to prevent air spilling over the sides of the aerofoil, reducing the lift. Air tends to flow from the high pressure beneath the surface to the low pressure above, so creating a trail of 'tail vortices' from both wing tips. End plates tend to prevent this end flow, but unfortunately the plate size needed to prevent these vortices must be so large that they create a significant amount of drag themselves. However, with the limited wing span of a Formula 1 car this 'artificial' means of raising the aspect ratio has its attractions. Much of this problem can be overcome using an elliptical rather than a rectangular wing shape in plan view - a shape such as was used on the Spitfire.' Robin Herd, *Autocourse*, 1968.





In ultra low drag form, the 711 came close to winning the 1971 Italian Grand Prix, the last F1 race held at Monza before chicanes were added.

Grand Prix, and to maximise its low-drag potential, the 711's front wing and most of the elements of the rear wing were removed. 'The 1971 race at Monza was the last time F1 cars ran at Monza before the chicanes were built,' recalls Herd. 'Because of the high speeds, the teams would look to cut drag as much as they could. The 711 was very much in its element at Monza, but it wasn't as fast as it could have been. Due to finances that year, Ronnie's engine should have been rebuilt two races before and so was way down on power. Ronnie finished second to Gethin's BRM by only 1/1000th of a second. With a fresher DFV it might have been different...'

The Monza race also brought to an end Costin's involvement with the 711. At the beginning of the project he had agreed to be paid a fee calculated on the amount of effective horsepower gain due to reduction of the aerodynamic drag of the car relative to the 701 it replaced. A method of determining the improvement was devised, but the track tests required to validate the figures never happened due to a shortage of budget. After the Italian Grand Prix Costin made calculations based on data from Monza, and showed a 60-70bhp improvement. March disputed the claim and Costin was not paid for his work on the car. Chastened by the experience, he never worked on another F1 project.

**SO NEAR, YET SO FAR**

With his 711 restored to its usual aero spec Peterson scored another second place finish behind Stewart in the wet Canadian Grand Prix at Mosport and, by the end of the season, had gained a total of 33 world championship points, securing the Swede second place in the driver's championship, and March fourth in the constructors' table.

A championship race win eluded the 711, but it did score one race victory in 1971 at the non-points Oulton Park Gold Cup with Henri Pescarolo winning the first of two races in Frank Williams' chassis.

'It was a good car everywhere really, and we were unlucky with the pitch sensitivity issues relating to the front wing, but the big disappointment of the 711 was that it wasn't actually any quicker in a straight line than the 701, and it's still not clear why that was,' says Herd. 'The 711 had a relatively long wheelbase, a low moment of inertia and was always very easy to set up. The 701 was the opposite.'

For a design so rooted in aerodynamic theory, the March 711 was devised with no use of a wind tunnel and never saw one until it had been raced several times. 'There was no wind tunnel model of the 711 before we built the full-scale car. What wind tunnel testing there was came after that. Compared to modern-day Formula 1 we were living in a completely different world.'

**A 2011 RE-APPRAISAL**

↳ *Racecar Engineering* asked Dr Mark Handford, who was chief aerodynamicist at Benetton and Jaguar and has worked on racecar aerodynamics for more than 20 years for his assessment of the March 711.

'A streamlined body with everything tucked out of the way can make a big drag reduction,' he said, 'but as March found with the 711, it's also an easy way to make life difficult for yourself with cooling the engine. As a result they ended up removing large parts of the bodywork and fitting larger radiators, which spoiled the original concept.'

'Given that an early '70's Cosworth DFV was only producing around 450bhp, Frank Costin's performance claim seems excessive and somewhat optimistic. It would probably have been possible to cut drag

is just behind the driver's helmet and so I doubt that there's low turbulent flow in that area. That would result in quite poor pressure recovery, compared to an airbox with a forward facing scoop inlet.

'The elliptical front wing looks distinctive, but I would question its use on a racecar. With an aircraft wing the target is not an elliptical shape but elliptical loading distribution. If you plot a graph from the centreline of a wing to the tip you ideally want to see a gradual reduction in the amount of lift produced the nearer you get to the tip.

'Racecar wings are limited on span and, as a result, tend to have a very low aspect ratio. That means that a lot of tip spillage will occur unless end plates are fitted.

'If you put end plates on a racecar wing you will create a

**“ The elliptical front wing looks distinctive, but I would question its use on a racecar ”**

by about 10 per cent with the 'streamliner' approach and, at 150mph, that might work out as a 30-40bhp gain, but if you then have to add bigger coolers and remove large parts of the bodywork you could easily lose the whole lot.

'Looking at the car with full bodywork as it was launched, they seem to have done a good job in reducing the drag resulting from the structure around the driver's head. There's a fairing behind the cockpit, but it's curious to see that the fairing is not swept down towards the rear of the car to make the wake of the car as narrow as possible. Instead, it just stops. Also, the apparent inlet to the engine is a single NACA duct on the top of the head fairing. NACA ducts work well when they are operating in a thin boundary layer and in low turbulent flow. But the NACA duct on the 711

given amount of downforce at a shallower angle of attack. You actually have less drag because you have more uniform loading across the span of the wing.

From a 2011 perspective, not using front wing end plates was quite a large mistake. Worse yet, it seems that the front wing was run desperately close to stall angle, so whenever the driver accelerated on corner exit, he probably lost most, if not all, of the front-end downforce.

'It's intriguing to think how the car might have performed if the nose wing support had been inverted, coming off the underside of the nose so that the wing itself ran in ground effect. The car would then probably have had all the downforce that it could use. It would have been more efficiently generated too, and would also have made the rear wing work better.'



**ACCRA LITE**  
performance forged  
pistons

A DIVISION OF



**ENGINEERED TO PERFORM**  
world leaders in high performance pistons



MANUFACTURERS OF WORLD CHAMPIONSHIP WINNING PISTONS  
FOR MOTOGP, WORLD SUPERBIKE & SPEEDWAY. WE POWER  
WINNERS IN THE AMA, LE MANS, BTCC AND MANY MORE...



**Omega Pistons**

Oak Barn Road, Halesowen  
West Midlands B62 9DW

Tel: 0121 559 6778

Fax: 0121 559 6779

info@omegapistons.com

www.omegapistons.com



**MOCAL** High performance  
air to oil coolers



Oil cooler  
installation kits



Remote filter heads  
& take offs



Electric water pumps,  
release engine power



Dashboard gauges



Oilstats control oil  
temperature for  
more power & mpg



**LAMINOVA**  
oil to water coolers



Electric oil pumps for  
transmission cooling



Holley & Facet  
fuel pumps



Custom hoses for oil, fuel,  
brakes & coolant, Aeroquip,  
ProGold, Moquip & Speedflow



World biggest filler  
cap distributor



Early warning  
switches & bulbs

Manufacturers of  
**MOCAL** & Moquip  
oil cooling equipment.  
Distributors of automotive  
fluid control products.

Online shop @  
www.thinkauto.com  
Catalogue £2 refundable.

**Think  
Automotive**

**www.thinkauto.com**

292 Worton Road, Isleworth, Middlesex, TW7 6EL

Tel 0208 568 1172 Fax 0208 847 5338

Email info@thinkauto.com



# Theory of revolution

Composites are an integral part of racecar construction, and now they have taken the next step: to the heart of the matter in the engine bay

Since the 1970s, composite materials have steadily replaced their metal counterparts in racecar construction, being used for every conceivable application from bodywork to gearbox casings. One area that has remained largely untouched by composite creep is the engine, mainly due to the high temperatures and vibrations, which are not conducive to the survival of composite components.

Beyond external ancillary items, its use for structural engine parts has been minimal, though pioneering work was done in the late '70s and '80s by Matti Holtzberg, owner of Compcast Technologies LLC in New Jersey, USA. Holtzberg developed a number of engine components for the ubiquitous Ford 2.0-litre Pinto engine using his patented Compcast plastic casting process. He cloned the 2.0-litre, eight-valve Ford product, and worked with this for several years, learning more about behavioural characteristics of the materials. The story then goes that when someone at Ford commented that the only components not covered were the block and the head, the idea of the Poly-motor was conceived. In 1980, the decision was taken to change some key areas of the design and develop a twin-cam valvetrain, based on the Ford / Cosworth BDA. Over the next few years the engine was refined and raced in a Lola 616 chassis in the Camel Lights series, and in the British Hillclimb Championship, in a Vision chassis.

Despite success on the track, the engine was not a commercial success, with US manufacturers only just waking up to the benefits of aluminium construction techniques. Moving away from the complete engine concept, the next two decades saw Holtzberg use his Compcast

process to develop components for other industries.

## HOLD THE FRONT PAGE

By 2004, the motor industry was becoming more receptive to the idea of mass-produced composite components. In 2009 a front page feature in the *New York Times*, focusing on the ideas Holtzberg had developed, brought the concept to the attention of the major players within the US automotive industry.

The key factors in this were the twin possibilities of reducing the manufacturing cost of a block

by 50 per cent, and its weight by up to 40 per cent, combined with considerable reductions in noise, vibration and harshness (NVH). This spurred Holtzberg into action and the decision was taken to develop a completely new block. 'I looked at all of the different blocks all over the world and settled on the Ford Duratec, which I decided had the best potential, from both an engineering and commercial perspective,' he says.

Huntsman chemicals, probably most familiar to readers as the producers of the Araldite adhesives range, were supportive

of the idea, and a project to reverse engineer the Ford block got underway. Due to other commitments, the new engine project could not take centre stage over Composite Casting's main product lines, so it was treated as part-time project and subsequently took nearly a year to complete the initial moulds.

## BLOCK MODIFICATIONS

During the reverse engineering process, a number of modifications to the normal Duratec block architecture were undertaken. 'Composites are different



Holtzberg saw his Poly-motor plastic engine concept fitted to a Lola 616 sports racer. Now he is using carbon fibre and hopes for equal success

LOLA/GARY HAWKINS



due to the fact they have an almost grain-like structure,' says Holtzberg. 'I tend to equate the high modulus fibres floating in a low modulus resin to the grain structure of forging steel. You try to control the structure to give you the optimum strength, and that is what is different [to cast aluminium]. With aluminium you have an isotropic structure with strength in all directions and you make it strong by adding ribs and reinforcements.' The actual fibres used are in the region of 6mm long and the moulds are designed to allow these fibres to be orientated in different directions, providing an anisotropic structure with strength in different planes. The moulding process is non-pressurised, relying on gravity to flow the material, and has proved highly successful for producing components from both Nylon 6 and carbon fibres, giving the same strength and finish properties as similar components made using injection moulding methods. In the

initial design for the composite block, all of the strengthening ribs were removed and analysis used to establish areas that should be made thicker or thinner to suit the characteristics of the new material. Holtzberg also ascertained that a number of the ribs on the production block played very little role in its structural integrity and were more to do with controlling NVH. 'It looks like they designed the basic architecture and then discovered that these aluminium blocks can be very noisy,' says Holtzberg. 'I feel that a lot of the [ribs] have other purposes than to stiffen an area, therefore we started off with a 'naked' block and worked from there.'

NVH is not such an issue with the composite design, thanks to the material's ability to dampen vibration, a fact that was discovered during the original Poly-motor project, with the engines being considerably quieter than their alloy brethren.

#### COOLER RUNNING

Coefficients of thermal expansion are also less of a worry, with the composite blocks running significantly cooler - around 15degF (6degC) - than an aluminium block, and the material is not a great thermal conductor. This is of vital importance to the structural integrity of the blocks, given that the higher the temperature, the less stable the material. To accommodate the resulting increase in cylinder temperature, the water jacket has been tweaked to ensure optimum heat transfer to the coolant.



**A typical die-casting die will cost \$1million, and it will be shot after 100,000 parts. With composites, up to a million parts can be made, with a lower priced die**

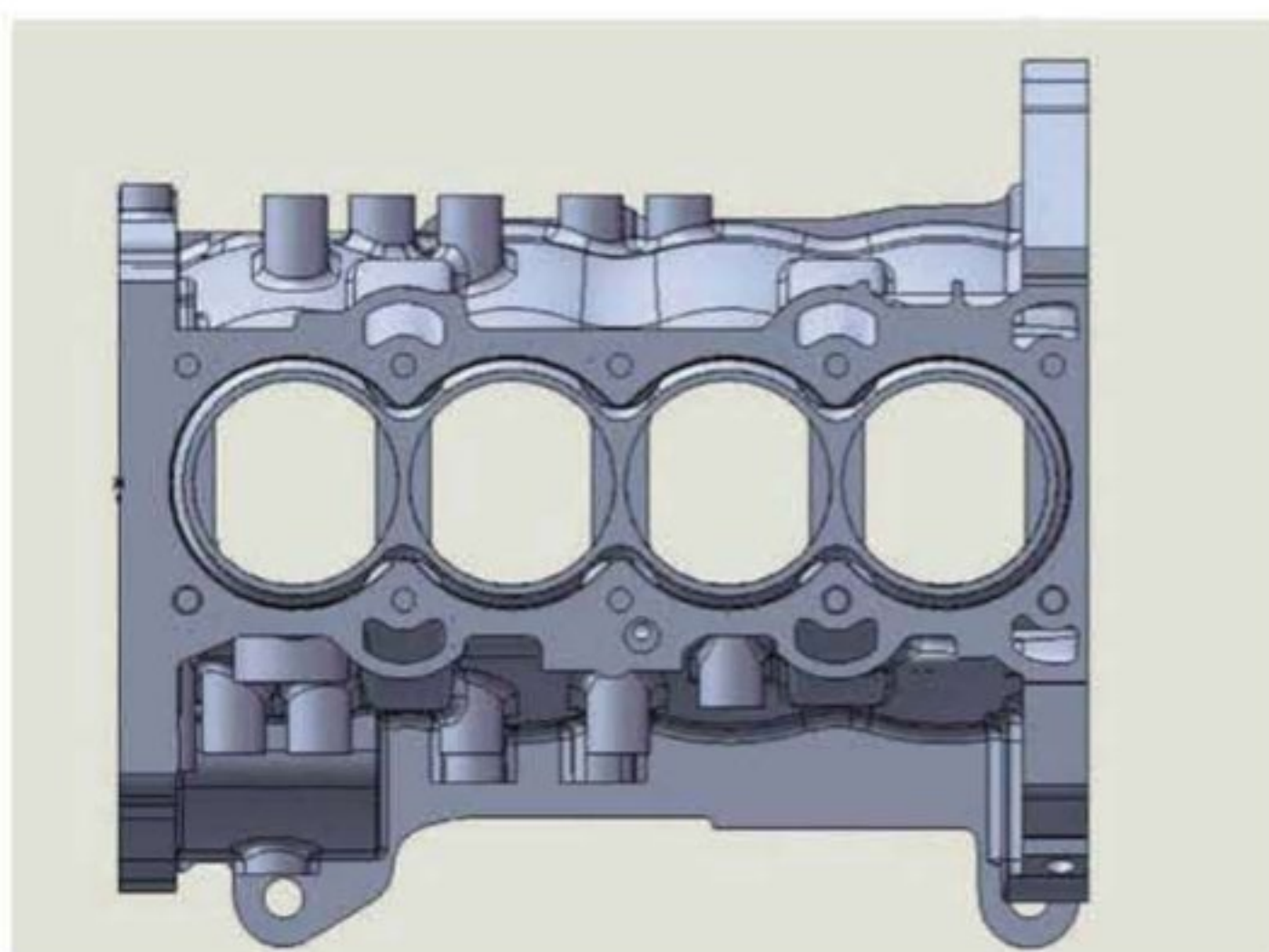

**The carbon engine concept offers dual advantages; it reduces the cost of a block by 50 per cent and its weight by 40 per cent**

The final key feature of the block design is the use of pressed-in aluminium cylinders, with each pair of bores siamesed together and located by a flange to the bottom of the block. This design gave Holtzberg two options in terms of lining the bores; either use a ductile iron sleeve or coat the raw aluminium. The previous Poly-motor had iron sleeves, but for the new design advances in the available technology made coating a viable option. The particular process used is supplied by Sulzer-Metco, and involves using a plasma spray to deposit a mixture of exotic alloys on the bore, providing a hard-wearing and efficient surface finish, without the prohibitive expense of creating liners from the same material blend. The end result is a further considerable weight saving - a ductile steel liner would weigh in the region of 18lb (8.16kg) whereas the alloy liner comes in at just under 9lb (4.1kg). The only other metal within the block is in the area of the main bearings, which feature an aluminium insert added during the casting process, principally to make align boring of the case more straightforward as the alloy is easier to machine than the composite material.

The plan is to run the motor with a standard Duratec alloy head, but there are plans to produce a composite head. There is also the potential to run a direct injection system, based on the Mazda MZR cylinder head, which shares the same architecture as the Ford unit.

#### FIRST TESTS IMMINENT

With the first engine due to run on the dyno imminently, it is likely that the new motors could be seen in competition in 2012-13. While the cost of the initial blocks will be very high in comparison to standard aluminium units, thanks to their bespoke nature, if they prove successful the process can be automated using existing gravity casting methods, greatly reducing the unit cost. This cost reduction will also be aided by the low pressure / temperature nature of the casting technique, which allows for moulds to be produced easily from low melting point alloys, removing the need for expensive steel items.

'We don't know how many blocks we will sell. We may sell five, we may sell 500. The main purpose of the project is to demonstrate a way to produce engine parts using metal casting methodology with composite materials. If you can die cast [a component] from aluminium we can die cast it from composite. A typical die-casting die will cost in the region of \$1million, and it will be shot after 100,000 parts. With our process you do not have the thermal degradation and could make up to a million parts, with a lower priced die to start with.'

Based on the success of the previous Poly-motor, and taking into account factors such as improved materials and a market more receptive to composite components, this may well mark the dawn of a new era in engine manufacturing.



**Matti Holtzberg pioneered the use of composite materials in structural engine parts**



Find more issues at  
magazinesdownload.com

# TOTAL SEAL®

*High Performance*  
PISTON RINGS

## The Leader in Piston Ring Innovation & Technology...

### Total Seal® Advanced Profiling™ Steel Rings

- Stronger and Longer Life – Most Precise Tolerances
- Thinner – Flatter – Lighter
- Conforms Better to the Cylinder Wall
- More Face & Anti-Friction Side Coatings
- Custom Sizing – Specialized Face Profiles
- Available In Gapless®, Napier or Conventional Styles

AP  
**ADVANCED  
PROFILING™**  
STEEL RINGS

### Total Seal® Diamond Finish\* Rings

- Axial Tolerances of  $\pm 1.27$  Microns
- Improved Sealing Between Piston and Piston Ring
- Optional PVD Coatings
- Custom Axial Thickness Down to 0.6mm
- Available In Gapless®, Napier or Conventional Styles

### Total Seal® Gapless® Top\*\* or 2nd Rings

- Increased Horsepower and Torque
- Wider Torque Curve
- Longer Engine Life – Fewer Teardowns
- Improved Consistency – Longer Ring Life
- Cleaner, Cooler Engine Oil – Better Oil Control
- Less Friction – Increased Horsepower
- Increased Intake Signal – More Engine Vacuum

\*\* Patented

If you've got a ring problem, we offer the technical expertise and assistance to help give you the Total Seal® horsepower advantage!

### Home of the Gapless® Piston Ring

Total Seal® pioneered this horsepower producing technology over 40 years ago and has been perfecting it ever since. Available in both our patented Top or 2nd ring applications.

UK distributor:  
**PERFORMANCE UNLIMITED**

Phone +44 (0) 1904 489332

Fax +44 (0) 1904 488355

e-mail [info@performanceunlimited.co.uk](mailto:info@performanceunlimited.co.uk)

[www.performanceunlimited.co.uk](http://www.performanceunlimited.co.uk)



Available from:  
**Total Seal, Inc.**  
[www.TotalSeal.com](http://www.TotalSeal.com)  
**800-874-2753 (U.S.A.)**  
**Tech Line: 623-587-7400**

\* U.S. Patent No. 6899595, U.S. Patent No. 7207870,  
U.S. Patent No. 7267602





# Sensor occasion

Knowing which sensors to log is a vital part of your data analysis programme

One of the most vexed questions I hear in the pit lane amongst race and data engineers alike is which sensors should be used on a car? It may seem like a trivial question, but it's one that is discussed at length. Too few, or the incorrect ones, and you could be missing out on some crucial information that could help you produce an accurate vehicle model. I've also seen a number of vehicle dynamics videos showing cars with so many sensors on you can barely make out the car underneath the instrumentation!

BY DANNY NOWLAN

There has to be a happy medium. The purpose of this article is to outline the sensors you *need* on a car so you can really get to the bottom of what the car is doing. Before we get to that, though, it is advisable to look at the racecar as a whole, and decide just what it is we need to log. After all, if you don't know what you need, how in the world are you ever going to get it? So to kick off this month's discussion, let us once again consider the beam pogo stick visualisation of the racecar, as shown in figure 1, overleaf.

As always, for simplicity I've omitted anti-roll bars and third springs, but you will soon realise that the following are important things to record and know:

- The movement of the chassis in pitch and roll
- Tyre movement
- Tyre loads at the point when the tyres hit the ground

The next step in our discussion is to consider what is driving our tyres. As a rough rule of thumb, tyre forces and what drives them can be described in equation 1, overleaf.

As we can see from equation 1, if we want to understand what the tyres are doing, we need to have sensors that can log the following factors:

- Slip angle and slip ratio
- Camber
- Tyre loads and temperatures
- Tyre rotational speed

Now that we know what we are after, we can use a bit of vehicle dynamics knowledge to help us fill in the blanks.

The first standout from both figure 1 and equation 1 is that if you are going to have any



**Equation 1**

$$\begin{bmatrix} F_z \\ T_t \\ V_{tyre} \\ \delta_{camb} \\ \alpha \\ SR \\ P_t \end{bmatrix} \rightarrow \begin{bmatrix} F_y \\ F_x \\ M_T \end{bmatrix}$$

where,  
 $F_z$  = vertical load on the tyre (N)  
 $T_t$  = mean carcass temperature of the tyre (K)  
 $V_{tyre}$  = rotational velocity of the tyre (m/s)  
 $\delta_{camb}$  = negative camber angle of the tyre (deg)  
 $\alpha$  = slip angle of tyre centreline relative to the ground (radian)  
 $SR$  = tyre slip ratio (ratio)  
 $P_t$  = tyre pressure (Pa)  
 $F_y$  = lateral force of the tyre (N)  
 $F_x$  = longitudinal force of the tyre (N)  
 $M_T$  = self-aligning torque of the tyre (N)

**Equation 2**

$$F_s = (k(x_s) + c(\dot{x}_s)) \cdot MR$$

where,  
 $F_s$  = the force of the spring damper unit at the wheel  
 $x_s$  and  $\dot{x}_s$  = the movement and velocity of the spring  
 $k$  = spring rate or function  
 $c$  = the damper rate or damper function specified at the damper  
 $MR$  = the motion ratio of the spring / damper unit, expressed as damper / wheel movement

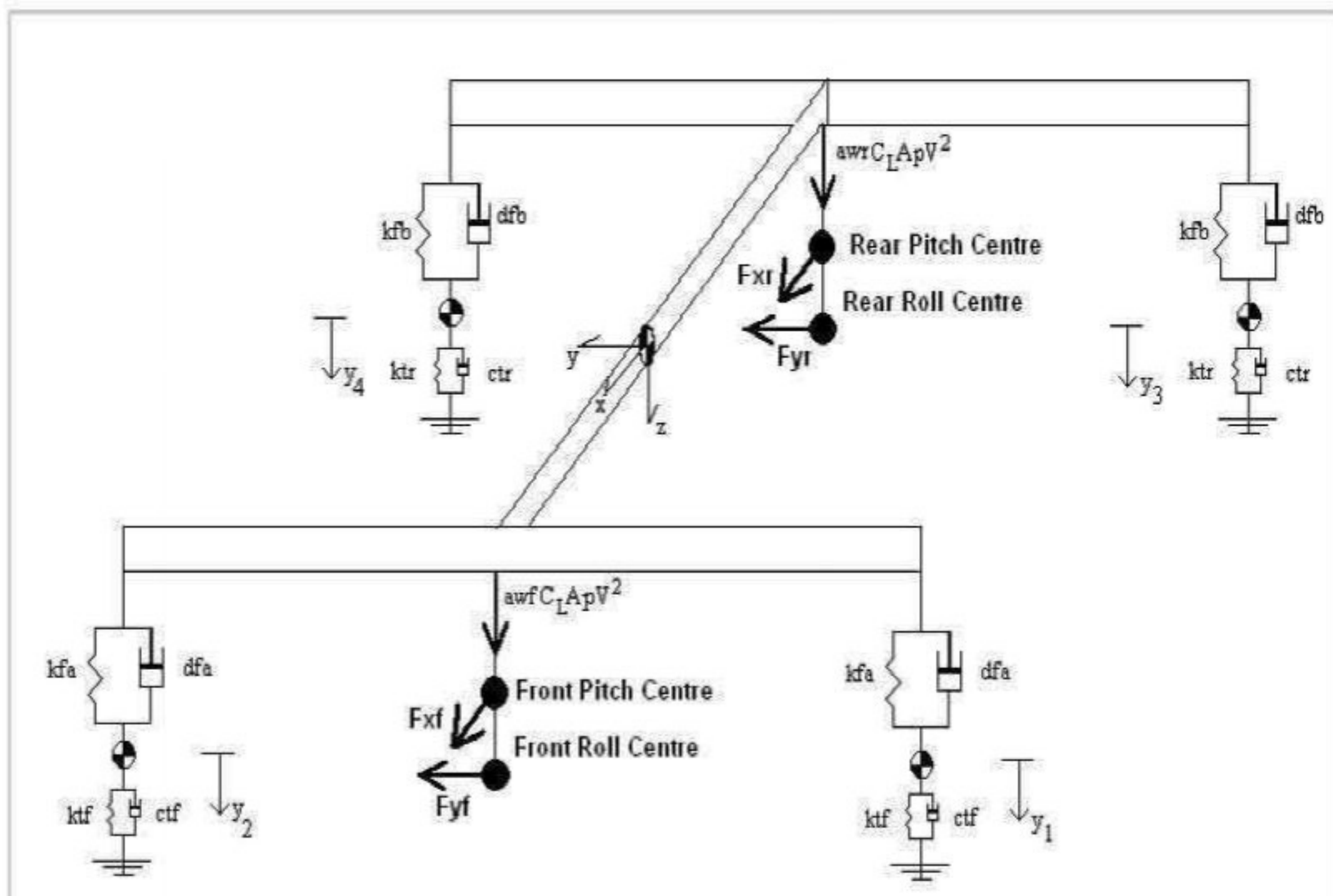

**Figure 1: the spring rate of your tyres (this determines the wheel movement)**

hope of divining what's going on, you need to run damper pots. I am astounded that there are some racing organisations and motorsport regulators who still refuse to see that this is a necessity. Examining figure 1 at the equilibrium case, or when the car is slowly moving, the spring force, and hence the tyre load, can be approximated by equation 2.

This is an immediate standout the moment you do a free body diagram of figure 1. Consequently, knowing the spring deflection is absolutely vital.

**TYRE CAMBER**

The other follow on from knowing your suspension movements is that you can determine the camber of the tyres. To do this from suspension movement alone, you need to know the following:

- The spring rate of your tyres (this determines the wheel movement that can be seen in figure 1)
- The vertical movement of your chassis. This can be integrated from vertical acceleration (that said, if you don't have that, calculating out your forces from suspension movement is a good approximation)
- Initial cambers measured from the ride height position

Once you have that, there is a plethora of kinematic software out there that will help you fill in the blanks. Alternatively, you can do it from first principles. It's actually not that hard - you just need to use programs such as Matlab or Maple and a bit of common sense.

The next item on the agenda is load cells. These help us nail down the loads at the contact patch, and they are also great for picking up chassis flexure issues. Also, in my experience, when I have been constructing aeromaps I have found that having strain gauges brings the aeromap to the next level. Nevertheless, it's amazing how far you can move forward on damper pots alone. In short, if budget is tight, buy the damper pots first, but plan to upgrade to strain gauges as soon as you are able.

Speed sensors, accelerometers, rpm and steering sensors come next. This section has its origins in equation 3 (below).

**Equation 3**

$$SR = \frac{\Omega \cdot R_0}{V} - 1$$

where,  
 $SR$  = slip ratio  
 $\Omega$  = rotational velocity of the wheel (rad/s)  
 $R_0$  = rolling radius of the tyre (m)  
 $V$  = forward velocity of the tyre (vehicle velocity) (m/s)

Engine rpm, combined with front or rear wheel speed sensors, will give us a very good knowledge of our slip ratios. For example, if we have a car that is rear-wheel drive, the rear slip ratios can be readily determined from looking at the front wheel speeds and comparing that to the rpm. It's also a great sanity check on our selected gears. It goes without saying here that logging gear number is a pretty good idea, too. Lateral and longitudinal accelerometers and speed sensors then help us fill in the following blanks for generating slip angles. To look at this in further detail, consider the equations below - 4, 5, 6 and 7 - for slip angles:

**Equation 4**

$$\alpha_1 = \delta - \frac{a \cdot r + V_y}{V_x + tr \cdot r}$$

**Equation 5**

$$\alpha_2 = \delta - \frac{a \cdot r + V_y}{V_x - tr \cdot r}$$

**Equation 6**

$$\alpha_3 = \frac{b \cdot r - V_y}{V_x + tr \cdot r}$$

**Equation 7**

$$\alpha_4 = \frac{b \cdot r - V_y}{V_x - tr \cdot r}$$

where,  
 $V_y$  = sideways velocity  
 $V_x$  = forward velocity  
 $r$  = yaw rate



Knowing forward speed and longitudinal acceleration gives us a clear picture of vehicle speed ( $V_x$ ). As we can see from equations 4-7, if we don't know forward speed we cannot calculate slip angle.

However, to finish calculating slip angles we also need to know yaw rate and sideways vehicle speed, which raises some interesting questions on what to do with lateral accelerometers. To consider this question in further detail, let's look at what the logged acceleration is telling you.

### Equation 8

$$a_{ymeas} = \dot{V}_y + V_x \cdot r$$

On paper, if we have lateral acceleration and yaw rate, all we need do is re-arrange equation 8 and we can integrate to find sideways velocity, which is in the realm of most data analysis packages. The only problem is that, strictly speaking, both the yaw rate sensor and accelerometer need to be mounted at or near the c of g of the racecar.

The work around for determining lateral acceleration and yaw rate is to mount lateral accelerometers on either axis of the car. For the sake of argument, let's say we have two lateral accelerometers -  $a_{yf}$  at the front axle and  $a_{yr}$  at the rear axle. It can then be shown that we have equations 9 and 10, below.

Here we are assuming the acceleration is being measured in  $m/s^2$ . If it isn't, simply multiply

the  $a_y$  terms by  $g$ . Equation (10) can then be integrated to give you yaw rate and, as I touched on earlier, most data analysis packages should be capable of doing this. The thing I really like about this approach is that it allows us to measure the axle forces on both ends of the car, which tells us a wealth of information about what the car is doing. However, for this approach to work, you need to know  $I_z$  and your data analysis software needs to have a good integration routine. If this is not the case, you are better off mounting a yaw rate / accelerometer at the c of g.

### TIER 1

This brings us to what I would call my Tier 1 level of sensors, or what I would want to have as

## your data analysis software needs to have a good integration routine

the bare minimum to construct a picture of the racecar.

- **Forward vehicle speed. If possible, four wheel speed sensors (though this is banned in some formulae)**
- **rpm**
- **Steering, throttle and brake pressure**
- **Damper pots**
- **A single lateral and longitudinal accelerometer fitted at or near the c of g**

While, strictly speaking, from a vehicle dynamics perspective we really don't need throttle and brake pressure, both these sensors tell you a great deal about how the driver is driving the car. Having the throttle trace will also help you tune in the tyre model as well, particularly longitudinally. My Tier 1b requests are then the following:

- **Everything in Tier 1**
- **Strain gauges to measure tyre loads**
- **Vertical g as wheel (three-axis accelerometers are now very common, so this is almost academic)**

Tier 1 will tell you 85 per cent of what you need to know, provided you have been sensible

gold because it gives a true picture of what is going on with the car, so you can really help the serious drivers achieve all they can and protect yourself from the wayward drivers.

### TIER 2

Our Tier 1 level of sensors is what I consider your basis, it's now time to add the sauce, or what I call the Tier 2 level of sensors. The first thing I would be adding in Tier 2 is laser ride height sensors, with a bare minimum of one at the front and two at the rear. Reviewing our beam pogo stick model from figure 1, and combining this with damper pots and load cells, this is what we can tell from laser ride height sensors:

- **Ride heights and roll and pitch angles**
- **The current tyre spring rates since we can now properly determine tyre spring rates by measuring tyre deflection**
- **If we are running four ride height sensors, we can also nail down chassis flexibility**

This new information, while we can *infer* it from the Tier 1 sensors, allows us to fully understand what's going on and really takes us to the next level.

The next thing I would be adding to the Tier 2 level of requests is tyre temperature and tyre pressure sensors, which further help you to understand what is going on with the tyres. Tyre pressure sensors are a no brainer. I've lost count of the number of times I've been in the pit lane sweating bullets hoping the tyre pressures work out. Usually they do, but this removes a layer of uncertainty. Tyre temperatures are the finishing touch, and allow you to understand what actually

with the tyre spring rates. The strain gauges will then get you to the 90 per cent point. I can tell you from practical experience that you can determine aeromaps and tyre models from this information, because what I've just listed is the basis of the ChassisSim monster file import system.

Finally, my Tier 1c requests would be the following:

- **Everything in Tiers 1 and 1b**
- **Either accelerometers on both ends of the car or a yaw rate sensor**

Upgrading to this will allow you to nail down slip angles but also, more importantly, will allow you to evaluate the car's stability index. The value of this is pure

### Equation 9

$$a_{ymeas} = wdf \cdot a_{yf} + wdr \cdot a_{yr}$$

### Equation 10

$$r' = \frac{\text{sign}(a_y) \cdot (a \cdot wdf \cdot m_t \cdot a_{yf} - b \cdot wdr \cdot m_t \cdot a_{yr})}{I_z}$$

Here we have,

$wdf$  = front weight distribution

$wdr$  = rear weight distribution

$a$  = distance of front axle to the c of g

$b$  = distance of rear axle to the c of g

$m_t$  = total mass of the car

$I_z$  = yaw polar moment of inertia

$\text{sign}(a_y)$  = 1 if right-hand turns are logged as positive acceleration, otherwise -1

**Table 1: approximate data logging costs**

Data sensor level	Approximate cost
Dash + Tier 1	\$10,000
Dash + Tier 1b	\$12,000
Dash + Tier 1c	\$14,000
Dash + Tier 2 - tyre pressure sensors	\$16,000
Dash + Tier 2 - tyre pressure and temperature sensors	\$18,000
Dash + Tier 2 - the lot	\$22,000



drives tyre grip generation. Combined with the tyre load, you should now be able to build up a complete picture of your tyres. Properly interpreted, this information is priceless.

The final thing I would add to my request list for Tier 2 is strain gauges on the suspension arms. This information will confirm your tyre force and is a fantastic cross reference if you have accelerometers at both ends of the car. In most cases you can get away with not having them, but having them there adds that final missing piece.

The great thing about all the sensors we have discussed

## quality data logging is exceptionally cost effective

is they can be easily fitted to the car. More importantly, they can be fitted in such a way that you don't need specialised bits with things pointing out of the car and potentially affecting performance, so the information you are logging is a true picture of what is going on with the car.

Naturally, cost will come into your decision making, so listed in table 1 is an approximate US

dollar value of everything we have been discussing.

These prices are, of course, only approximate, but they give you some idea of the amounts we are looking at. Putting them into context, if, say, a Porsche 997 GT3 Cup car costs approximately \$300,000 (£183,000), an engine re-build approximately \$15,000 (£9,150), depending on your engine type, and, for

a professional race team, the sticker price to get the crew to a single event and run the car is approximately \$10,000 (£6,100) per meeting. Now remember, with your data logging you pay this price only once, and then have an invaluable resource you can draw on time and time again. It's not hard to see then that having good quality data logging is exceptionally cost effective, so don't let anyone tell you any different.

While this is by no means the last word on what sensors you need to put on your car, it is a good starting point and will provide you with invaluable information as you seek to



# SPECIAL SUBSCRIPTION OFFER

**ONLY £60**  
per year  
**USUALLY £72**

**Save £12/\$15 every year**

- ➔ £1 per issue off the usual rate
- ➔ Free delivery to your door

SAVING OVER **15%**

Subscribe **NOW**

By telephone: +44 (0)1858 438443 quoting P108

Online: [www.subscription.co.uk/racecar/P108](http://www.subscription.co.uk/racecar/P108)



## Racecar Engineering magazine subscription

Rate for 1 year (12 issues)

- UK **£60** (usually £72) – £12.00 off!
- USA **\$120** (usually \$135) – \$15.00 off!
- Rest of World **£72** (usually £84) – £12.00 off!

Rate for 2 year subscription (24 issues)

- UK **£110** (usually £144) – £34.00 off!
- USA **\$225** (usually \$270) – \$45.00 off!
- Rest of World **£130** (usually £168) – £38.00 off!

## Or subscribe to our digital edition



- ➔ Download to your iPad, PC or Mac
- ➔ Instant delivery worldwide!
- ➔ Adjustable font size for easy viewing

Go to [www.Racecar-Engineering.com/P108](http://www.Racecar-Engineering.com/P108)



# AMARI AEROSPACE LTD

*Quality Service Providers of Aerospace Metals*

- ALUMINIUM
- STEELS
- TITANIUM
- NICKEL ALLOYS
- BAR
- PLATE
- SHEET
- TUBE
- SAWING
- GUILLOTINING
- ETCHING
- TESTING



For a prompt, courteous and competitive quote, please contact our motorsport sales team on:

Tel: +44 (0)2380 742 750 Fax: +44 (0)2380 741 947  
Email: [sales@amari-aerospace.com](mailto:sales@amari-aerospace.com)



[www.amari-aerospace.com](http://www.amari-aerospace.com)



**texense**  
by TEXYS

TEXYS designs, manufactures and distributes a range of sensors for racing, automotive and industrial applications:

- Infrared temperature sensors (for tyre, brake disc, clutches...)
- Thermocouple amplifiers (patented)
- Accelerometers and gyroscopes
- Strain gauge bonding + amplifiers (push rods, wishbones...)
- Pitot sensors and differential pressure sensors
- Gear shift devices (flexion and tension/compression model)

TEXYS is renowned for **product reliability and accuracy** and is consequently called upon to work with major professional teams and manufacturers. The company has been working with motor sports professionals **since 1999** and is involved in all the main international motor racing championships: Formula1, MotoGP, WRC, Nascar, IRL, Le Mans Series...

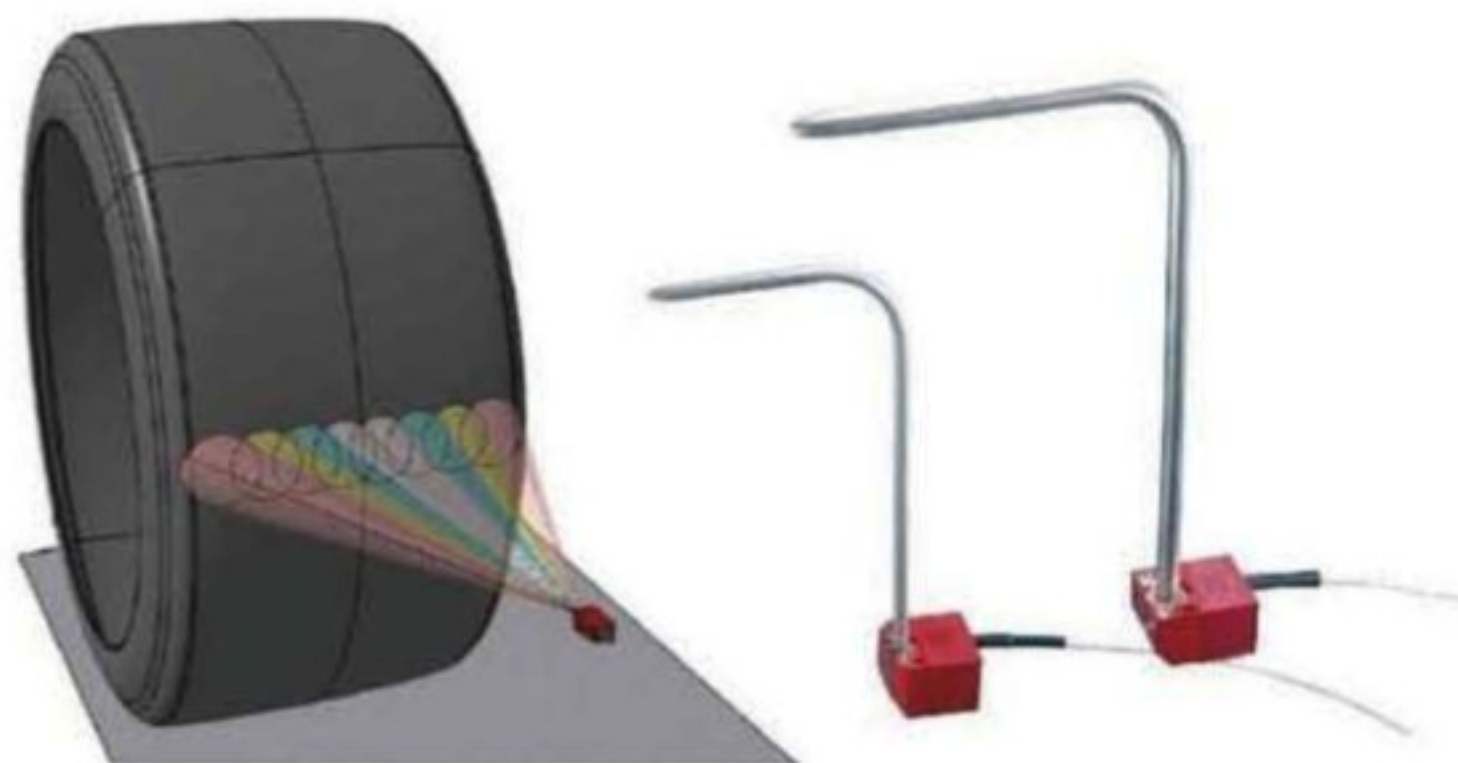

Our multi-expertise set up enables us to work on the customised development of specific analogue and digital sensors. Our products are distributed through a network of agents and through our subsidiary in the United States.

[www.texense.com](http://www.texense.com)

Tel : +33 (0) 386 21 27 18

**texense**  
world pro by TEXYS



# More than a badge

**As far as Chevrolet** Director of Racing Mark Kent is concerned, the 2012 IndyCar engine bearing his company's name will be more than just badge engineering. It will reunite Chevrolet with Ilmor, which first supplied the company with engines in 1986.

In 1994, Ilmor turned its attention to the infamous 1024hp 3.4-litre Mercedes-Benz push rod, which took advantage of a loophole in the rules to win the 500. Illien first approached Chevrolet with this idea but the vehicle manufacturer pointed out that it was already had its Buick pushrod engine programme for Indianapolis. Design work at Ilmor was carried out in such secrecy that drawings were sent to suppliers carrying false name, such as 'Pontiac'. It was only in the month before the 500 that Mercedes-Benz agreed to give its name to the unit.

At the end of the year the pushrod engine was banned but the Mercedes-Benz name continued on the Ilmor 2.56-litre unit, which, of course, had started off as a Chevrolet. Such is the world of badge engineering.

Kent says that all has now changed, and Chevrolet has been



**All Chevrolet is [at present] prepared to show is this basic illustration**

highly involved in the design and development of the new IndyCar engine from the outset, with technology transfer a key element of the work. 'Unlike other programmes where people buy the valve cover and put their name on it, we really wanted to play a role on the development of this engine. The technologies that are in the rule set for the IndyCar engine are exactly the same as those who want to apply to production cars - to improve fuel efficiency and improve emissions.'

The engine is a 2.2-litre, aluminium block, aluminium, direct injection V6 with twin turbochargers. Kent admits that the use of twin turbo may not be consistent with what other manufacturers will offer. However, he believes that the enhanced responsiveness of two, smaller turbos will offer an advantage on road courses where the driver is on and off the throttle. On ovals it will make no difference.

The turbochargers will come from a common supplier whatever

the engine. All the twin turbos will be to the same design, likewise the singles. 'In this way, the IndyCar Series will maintain a closer performance level, contain costs and protect us from ourselves,' quips Kent. As yet, the IndyCar Series has not announced who will supply the turbo.

The use of small displacement, turbocharged, direct injection V6 engines fuelled by E85 is mirrored by Chevrolet's production car development. Cars from either end of the spectrum such as the Cruze and the V6 Camaro use direct injection. 'One area we initially discussed with Ilmor was how we could help them. They recognised they did not have a great deal of experience in these two fields but that we did.'

In addition to providing its resources and expertise in direct injection and E85, Chevrolet has seconded a young engineer from its powertrain group, Matt Wiles, to Ilmor's Northamptonshire base, where he has become fully integrated. Kent reports that Wiles, who has written SAE papers on E85 and direct injection, 'has contributed greatly in the development of this new engine. It is one area where we think we

## P&O offer

**P&O Ferries** offers the widest choice of routes and the most frequent service to the Continent via its Dover to Calais, Hull to Rotterdam and Hull to Zeebrugge routes. The company introduced new ship the Spirit of



Britain on its Dover to Calais service in January at a cost of £150 million and a second ship, the Spirit of France, will join her in September. The pair are the largest and most revolutionary ships ever to be seen on the Dover Strait, offering unparalleled levels of comfort and convenience with the capacity to carry up to 2,000 passengers and a dedicated car deck for passengers.

Fares on the Dover to Calais service start from £35 each way for a car and up to nine passengers. Upgrades to include Club Lounge cost £12 per person each way when pre-booked, and Priorite is £12 per car each way, or £6 per car each way if booked with Club.

## DJ Firestorm off to a blazing start

**Wallace Menzies**, owner of the 3.2 DJ Firestorm hill climber, which is powered by a Cosworth XD and has featured extensively in Racecar Engineering, has seen considerable success in the British Hill Climb Championship. The car secured a brace of second places in rounds 7 & 8 of the championship at Gurston Down, Wiltshire, UK, on May 29th. Despite a horsepower deficit compared to the NME V8 and Judd V8 powered cars, it attained the fastest

finish-line speeds (a best of 153mph in the class runs), suggesting very good aerodynamic efficiency. The car runs DJ-manufactured, Wing Shop-designed wings, and Simon McBeath of The Wing Shop, SM AeRo Techniques and long-time Racecar contributor, provided assistance for the overall aerodynamic design of the car. The Firestorm was also aerodynamically refined in the MIRA full-scale wind tunnel over the winter.



## BRIEFLY...

### Composite expansion

Carbon fibre specialists Amber Composites recently announced that the company has broken ground on a new building at its production facility in Langley Mill, Derbyshire, UK. The building will be dedicated to the production of composite materials including Amber's prepreg, surface film, adhesive film and syntactic core products, and will more than double their production area. 'The demand for lightweight materials continues to rise,' said Managing Director Jonathan McQueen, 'and we're investing in technology, equipment and facilities to meet that demand while keeping our lead times as short as possible.'

### VI-grade conference

VI-grade GmbH, a provider of products and services to bridge the gap between technical simulation and real world testing, has announced that the fourth edition of the International Users Conference on October 18th-19th. Following the first three conferences, respectively held in Marburg, Udine and Bad Nauheim in 2007, 2008 and 2010, VI-grade has decided to host the 2011 event in Udine, Italy.

### New machining solutions

Tooling manufacturer Dormer Tools has invited manufacturing firms to test its new 'productivity centre,' based in Yorkshire, UK. Equipped with a wide range of machining centres, the intention behind the initiative is to demonstrate to companies how tooling can aid production efficiency. John O'Donoghue, general manager at Dormer Tools, said: 'Dormer's significant investment in R&D means that our cutting tools are designed to last longer and work more efficiently, providing our customers with cost-effective solutions that give value for money.'

have more experience than our on track competition.'

To further enhance the technology transfer Chevrolet has called upon its production engine supplier base to be involved. 'We are going to take the enhancements we learn and incorporate them into our production engine portfolio.'

There is much that Kent will still not say about the engine and that includes the identity of these suppliers. 'This is going to be a whole new technology and we want to keep it, our partners, our approach and concept under wraps for as long as possible.'

Most of the initial concept work for the engine was carried out by Ilmor. 'We relied on them for the initial studies and then brought our expertise to the areas we felt we best could,' said Kent.

All components will be engineered at Brixworth but it is as yet uncertain where they will be manufactured. The engines will certainly be maintained at Ilmor's North American facility at Plymouth, and Kent envisages that some of the components will come from there. Conveniently, Plymouth is about 10 miles from Chevrolet's Wixom test facility, where race development of the Corvettes is carried out.

The first engine will have run

by the end of June. Track testing is scheduled to commence in the third quarter of the year, probably in September. By that time Chevrolet hopes to have its customer line-up in place. Team Penske - which was instrumental in bringing Chevrolet back to Indianapolis for 2012 - is the only one so far to have been announced, in the same way as Honda said Target Chip Ganassi was to be its 'anchor team' the week of this year's Indianapolis 500. Neither Kent nor Chip Ganassi like the term, as all

**“ this is going to be a whole new technology ”**

customers are to be treated equally. 'We are hoping to get several high quality teams and have them work together to elevate the Chevrolet family.'

With around 24 to 27 full-time entries projected, and three possible engine manufacturers, Kent will be happy if Chevrolet can power nine or 10. 'For one manufacturer to have a disproportionate share would be against what we are all trying to achieve,' he said. As yet, the IndyCar Series has still to announce how it makes sure each has its fair share. Each

participant will pay \$690,000 under a lease agreement, considerably less than at present. This sum will be consistent across all manufacturers to avoid any one being more financially attractive than the others. Ilmor will provide the engines directly.

It is important that the customers are all known prior to testing, as Chevrolet then wants the teams to participate 'aggressively' in the development process. 'To come to one of our tests you have to be aligned to us,' said Kent.

Engineers, mechanics and drivers are all going to be asked to attend so that when the teams take delivery of their own chassis in December 'they will be so much further ahead.'

Honda is currently ahead in the testing programme, by up to two months, but Kent is relaxed that Chevrolet is on schedule.

Chevrolet also intends to supply an aero kit which, like the engine, will be a collaboration 'providing our own internal resources with those of a technical partner (yet to be announced).' Any team wanting to run with such a kit will, logically, have to use a Chevrolet engine. However, it will still be possible to use the standard, default Dallara aero kit. 

## Students heading to DC in 2012

English R&D firm DC Electronics is repeating its highly successful Formula Student workshops next year. This time the events aimed at those taking part in FSAE competitions are being run in conjunction with connector supplier Deutsch Autosport. The half-day wiring loom workshop is designed to give students the opportunity to get the full potential from their cars. Attendees will learn how to design and build a bespoke and winning wiring harness from one of the most knowledgeable and technically advanced teams in the business. In addition, DC Electronics is also

offering exclusive discounts on wiring products and hardware from manufacturers including Cosworth, DTA, GEMS, MoTeC, OBR, Race Technology and Stack. David Cunliffe, Director and Co-founder of DC Electronics, said: 'Formula Student is a fantastic initiative which provides our budding motorsport professionals of the future the opportunity to compete with each other on the international stage for the first time.' DC Electronics has more than 10 years experience in the design and build of high quality, professional and reliable electrical systems

for the motorsport and high-performance road car industries. Their products can be found in rally, world touring cars, GT, NASCAR, superbikes, F1 and even power boats. Deutsch Autosport connectors are specified across the world of motorsport. A company spokesman said 'we're pleased to support Formula Student teams and the training programme with DC Electronics after the success of the previous years' events, and are committed to expanding the use of the top level components and techniques to the very start of students' careers.' Both companies will be represented at Silverstone for Formula Student on 15th July.



## RACECAR ENGINEERING COMPETITION

Win these 4 VELOCE books worth **OVER £100!**



Here at Racecar Engineering we've teamed up with Veloce Publishing to offer one lucky reader four of the most exciting technical books in the industry.

### **Forza Minardi!**

by Simon Vigar

### **Bluebird CN7**

- The inside story of Donald Campell's last Land Speed Record Car  
by Donald Stevens

### **BRM V16**

by Karl Ludvigsen

### **Alpine & Renault**

- The Development of the Revolutionary Turbo F1 Car: 1968 to 1979  
by Roy Smith

---

## **ANSWER THIS SIMPLE QUESTION**

How many valves does the Audi R18 have in its engine?

---

**ENTER ONLINE AT**

**[www.racecarengineering.com/veloce1](http://www.racecarengineering.com/veloce1)**



## STRAIGHT TALK

# Bernie and the F1 sale



PAUL J WEIGHELL

For Sale. One used TV show. 525 million viewers. POA (ludicrously large offers only). No time wasters. Terms and conditions apply. Genuine reason for sale, owner retiring...

**B**ernie Ecclestone has not only hinted at retirement, but seems to be hyping the sale of at least two assets - F1 and Queens Park Rangers FC. I say 'hyping' loosely as he is in fact loudly acclaiming that no one has even contacted him to enquire if the assets are for sale, which may be as near a for sale sign as he wishes to admit.

Ecclestone's public statements regarding the possible sales of F1 and QPR, as well as the throwaway comment he made about his own pension, have all come within a very few weeks, so perhaps there is some meat in the rumours of the much-vaunted Ecclestone exit.

He purchased the F1 commercial rights lease from the FIA for just \$386m in 2001, and that lease still has some 90 years to run, which is long enough for almost anyone to make a decent return on the sport's commercial business, as long as that business can be kept going without Ecclestone.

CVC bought about 63 per cent of the business in 2006, and has since spent time making it a more integrated and professional-looking business organisation.

It's now up to CVC to try and set a sale price, and Ecclestone would no doubt be pleased to receive some more cash for his stake if he sold that as well. I lose count, but is it not three times now that he has bought / sold large chunks of F1? There is an apocryphal tale of the famous Warren Street used car dealer who regularly re-sold his pet homing pigeon. At the end of 2012, the

current Concorde Agreement lapses and, if the unseemly mess that was the re-negotiation last time is anything to go by, then there may never be a new one. I spoke to someone recently who had signed the current Concorde, but admitted to being not too familiar with its contents. It is a most curious contractual document and, if anything encapsulates Bernie Ecclestone's career in a nutshell, it is the Concorde Agreement.

However, the usual pre-bargaining noises about breakaway series are already being heard from the wings, and Ecclestone has already responded

**the usual breakaway threats are already being heard**

by mooted the idea of charging teams annually to enter F1 if they won't sign another Concorde. CVC would love an income stream from the teams rather than having to pay them 'benefits', so the war has already started with opening salvos fired in both directions. No doubt the new Concorde story will run and run until Ferrari et al get more money and go back to work, just like any other trade union.

What, then, is F1 worth if a sale does happen? The total Delta TopCo revenue earned since CVC purchased their stake is estimated to be about \$5.9 billion, on which the net profit was about \$1.2 billion. A nice little earner then.

Half a billion here, half a billion there and pretty soon you're

talking real money.

A recent estimate values Delta TopCo at \$5-7 billion, which would need a nine to 14-year payback period, given an annual \$500m profit, all other things being equal. This is an over-high valuation estimate in my opinion, as Formula 1 may not last as profitably for another 10 years, but then I am not a likely buyer and only the final buyer will set the price.

Ecclestone and his family trust still own about 14 per cent of Delta TopCo, but it must be remembered that CVC have first refusal on equity sales, as well as a locking approval clause on any new owners. And a sale without Ecclestone as CEO may be worth less than a sale with him. But then he is not as young as he once was either...

Unlike CVC and F1, however, QPR is Ecclestone's lone decision to sell, as he owns 62 per cent of the football club that he and Briatore bought for around £14m. Although he does have to give first refusal to Briatore, it is still likely that the club could now sell for somewhere around the £100m price tag publicised. Given that QPR was losing some £15m a year before making it to the Premier League, the new TV cash flow is worth the difference. Perhaps to bolster the team's balance sheet for a sale, QPR has just hiked ticket prices by 40 per cent, so any Australian media-owning businessman who might be hoping that Bernie has gone soft in the head is just not betting sensibly!

## WRC gets connected

**Mobile phone** manufacturer Nokia has teamed up with the FIA World Rally Championship (WRC), as part of a new multi-year partnership. The agreement confirms Nokia as an international partner for the championship, with the intention of bringing a new technological experience to the fans. This will include an exclusive mobile application, providing access to video footage, live standings and car telemetry data. The app will help fans keep up to date with the performance of their favourite teams, and track their position on Nokia maps, as well as bringing the latest news, stories, and up-to-date information on the WRC calendar. Jerri DeVard, Nokia's Chief Marketing Officer said: 'We are excited to be partnering with North One Sport on the World Rally Championship. This is a great opportunity for Nokia to connect people around the world with their passion for rally sports and Nokia will make the WRC experience more accessible on their mobile phones.'

## Rising energy cost concerns

Sixty per cent of manufacturers say that rising energy costs are of high concern to their business, placing them above labour costs, falling consumer spending and the administrative burden of regulation, according to a new survey by the Institution of Mechanical Engineers. IMechE President John Wood said: 'The UK is showing clear leadership by moving forward to a low carbon economy, and this is going to mean higher energy costs for everybody. But manufacturers are worried, and the government needs to make sure it doesn't force energy intensive industries out of the UK and into countries with more lax climate change targets.'





In association with **Racecar**  
engineering

## What's on and when at the 2012 event

It may only be July, but the motorsport industry is already gearing up for next year's International Motorsport Business Week, which takes place from 9-15 January 2012. The week draws together an extended range of focused business and networking opportunities in order to launch the 2012 motorsport season, culminating in Europe's largest dedicated motorsport trade show, Autosport International.

The motorsport industry is worth more than £4.6 billion in the UK alone, and the week provides those involved with the opportunity to nurture existing relationships and generate new business. It acts as an information hub to find out about the latest news and launches within the sector.

Supported by Racecar Engineering, International Motorsport Business Week comprises conferences, seminars, an international business exchange and an industry awards dinner.

### **Autosport Engineering in association with Racecar Engineering** 12-13 January 2012 - NEC, Birmingham

A dedicated two-day trade only 'show within a show' that is integrated within Autosport International, aimed at specialist suppliers to the motorsport and performance engineering sector. The show embraces the crossover of technology from other industries and showcases new suppliers and manufacturing expertise, creating new business and networking opportunities.

### **Autosport International** 12-15 January 2012 - NEC, Birmingham

As the world's largest motorsport show, Autosport International is the place to start the motorsport season. It covers all areas of the sport, both professional and grass roots, from Formula One all the way through to karting. The must-attend event incorporates two trade days followed by two public days, catering for the industry and motorsport fans alike.

### **MIA** **MIA's Low Carbon Racing Conference** 11 January 2012 - NEC, Birmingham

The sixth MIA 'Low Carbon' Cleaner Racing Conference will take place on the Wednesday 11 January at the NEC. The conference provides an opportunity to listen to experts on alternative fuels, renewable energy and how lessons learned on the race track can benefit the wider automotive industry.

### **MIA's Business Awards Dinner** 12 January 2012 - NEC, Birmingham

The MIA Business Awards Dinner recognizes business excellence at all levels within the motorsport industry.

Held on the evening of Thursday 12 January to conclude the first day of Autosport International, the MIA Business Awards provide another valuable networking opportunity amongst leading companies from the motorsport industry and attracts over 500 international guests.

### **MIA's Workshops** 12-13 January 2012 - NEC, Birmingham

Each year on the first two days of Autosport International the MIA offers a programme of free business workshops, which are open to MIA members and non-members alike.

### **UKTI International Business Exchange** 12-13 January 2012 - NEC, Birmingham

The International Business Exchange (IBEX) is a match-making event consisting of one-to-one meetings between international visitors and UK suppliers. Hosted by UK Trade and Investment in association with the MIA, the IBE takes place on the International Business Lounge on the Thursday and Friday trade days of Autosport International.

### **Motorsport Safety Fund "Watkins Lecture"**

**13 January 2012 - NEC, Birmingham**  
The annual Watkins Lecture on motorsport safety issues has become an integral event at Autosport International and is primarily for the benefit of those directly involved in marshalling and safety in motorsport. Previous speakers have included Malcolm Wilson, Sir Jackie Stewart, Max Mosley, Niki Lauda, David Richards, Ross Brawn and Bernie Ecclestone. Attendees for 2011 included Christian Horner, Adrian Newey and Martin Brundle.

## EXHIBITOR NEWS

### **RETURNING EXHIBITORS TO AUTOSPORT INTERNATIONAL**

A total of 82,000 visitors attended Autosport International in 2011, with 28,900 motorsport trade buyers from 50 countries helping to generate £800 million worth of business across the four days.

The success of the show means that stand bookings for the 2011 show are already well underway with many returning exhibitors securing their space.

### **GEMS Performance Electronics**

Another success story from the 24 hours of Le Mans, GEMS supplied the cars that finished second, third and fourth overall in the highly prestigious endurance race, as well as the winners of the GTEPro Class with the GEMS LDS4 driver display. A leading developer and producer of engine management, transmission control, data acquisition and in-car display systems, both within motorsport and in other industries such as aviation, GEMS will be exhibiting at Autosport International for the fourth year in 2011.

Recently GEMS has also supported Briggs Automotive Company (BAC) with its new project, the BAC Mono, which launched in April this year. The ultra-light single-seater trackday car uses a GEMS EM40 ECU to control its Cosworth engine and its LDS4 colour display.

GEMS' Sales and Marketing Executive Richard Huff said: "Autosport International puts us not only face to face with existing clients, but also new customers. Ultimately it is a networking event for us, along with increasing our media exposure. We are planning to launch some new products towards the end of this year and will have them on display at the show."

### **MoTeC Europe Ltd**

Banbury-based MoTeC will also return to the Birmingham NEC in 2012. The engine management and data acquisition company has recently been chosen by V8 Supercars Australia as the exclusive supplier of electronic systems for its Car of The Future (COTF).

MoTeC has been the control supplier of engine management to the V8 Supercars for a number of years, and from 2013 the V8s will use the M190 ECU to manage all aspects of the engine, including fuel and ignition, RPM limiting, fuel pumps and pit lane speed limiting.

Each car will also incorporate the MoTeC ADL3 (Advanced Dash Logger), which stores data and transmits telemetry data for the teams to monitor many parameters.

The MoTeC SLM (Shift Light Module) and Video Capture System (VCS) will also be fitted, indicating gear change points and allowing further data analysis, especially in the event of an incident investigation.





**TRADE-ONLY DAYS**  
12 & 13 JANUARY 2012

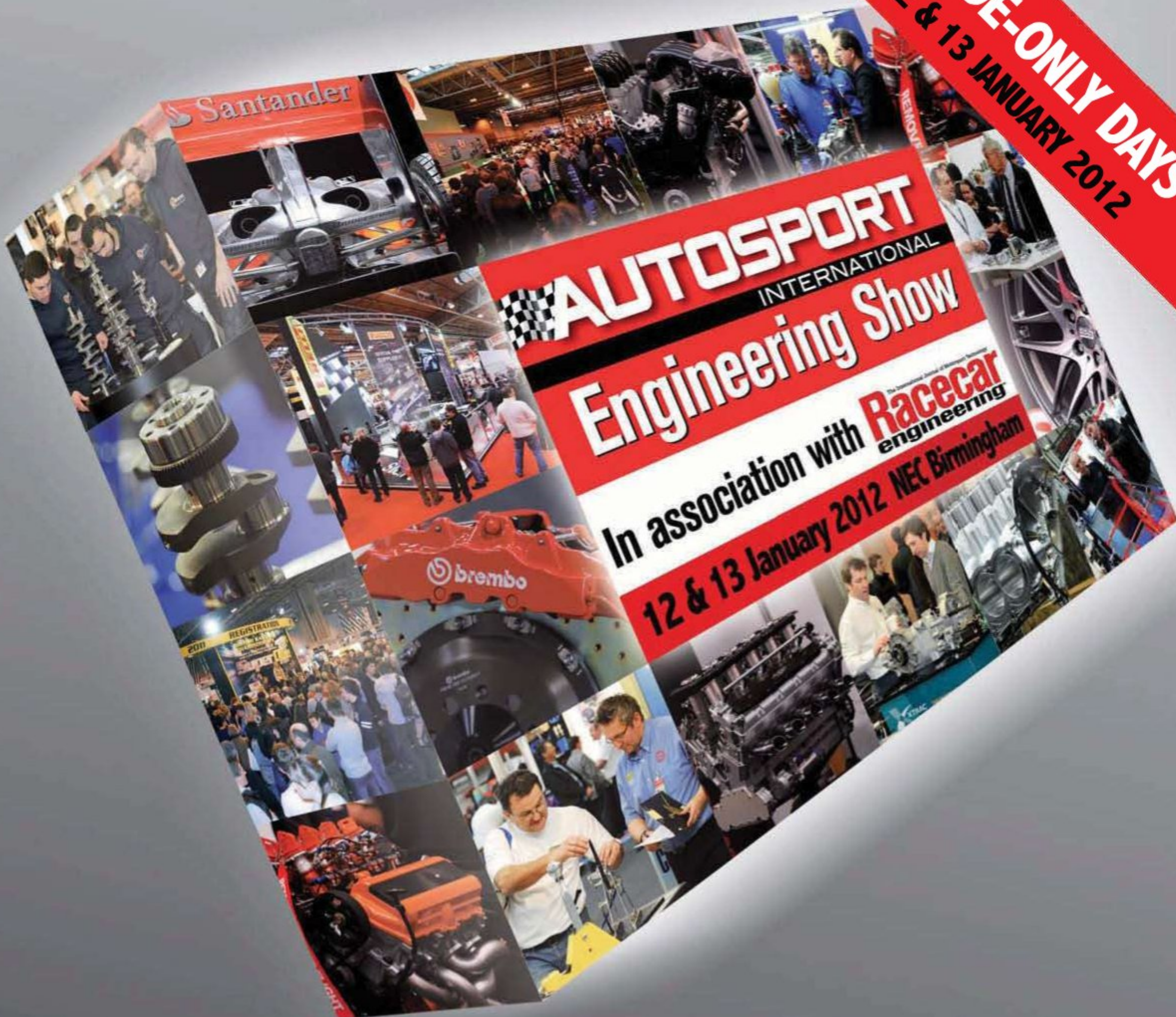

**GEAR UP FOR 2012!**

- £800m+ worth of business generated in 2011
- Over 28,000 motorsport trade visitors from over 50 countries
- 67% of trade visitors have sole or joint responsibility for purchasing
  - 53% of trade visitors do not attend any other exhibitions

**FOR INFORMATION ABOUT EXHIBITING**

call: **020 8267 8300**

visit: **[www.autosportinternational.com/trade](http://www.autosportinternational.com/trade)**

email: **[tony.tobias@haymarket.com](mailto:tony.tobias@haymarket.com)**



Wm. C. Mitchell Software - Racing by the Numbers  
 Introducing version 4.02 of the WinGeo3 Suspension Geometry program with Force-based Roll Centers  
 ----- explained! -----



www.MitchellSoftware.com  
 800-844-7296 from USA and Canada  
 125 East Plaza Drive, Suite 117

704-660-0330 voice  
 704-663-0085 fax  
 Mooresville, NC 28115 USA

## Dunnell Engines

Duratec and Zetec engines and components for road and race

**Duratec full race and rally applications**

**zeturtec**  
 Duratec Engine  
 2.0-2.5 Litre  
 200-330 BHP

**zetec**  
 Zetec engine  
 1.6, 1.8 & 2.0 litre  
 175-270BHP

Knut Ove Borseth -  
 2009 European Rally Cross Champion  
 Using our latest Duratec RX series engine



**Complete engine & component development**  
[www.dunnellengines.com](http://www.dunnellengines.com)  
 Tel: +44 (0)1449 677726 Email: info@dunnellengines.com  
 Unit 10 Tomo Business Park, Creeting Rd,  
 Stowmarket, Suffolk, IP14 5AY, England

## Autotel Digital Race Radio

### Motorsports Communications Systems

Complete Range of analogue & digital Race Radio systems for all levels of motorsport.

Show discounts

Dealer Packages

Autotel Race Radio  
 0044(0)1508 528837  
[www.raceradio.co.uk](http://www.raceradio.co.uk)



## The Difference is Clear



# SBD Motorsport

Vauxhall, Ford Duratec & Hayabusa  
 MBE Management systems, kits & components available



**MBE9A8**  
 Fuel injection up to  
 8 cylinders



**MBE9A4**  
 Fuel injection up to 4 cylinders



**MBE9A4i**  
 Ignition only up to  
 4 cylinders

Unit 15, Red Lion Business Park, Red Lion Road, Surbiton, Surrey KT6 7QD  
 Tel: 020 8391 0121. Web: [www.sbdev.co.uk](http://www.sbdev.co.uk). Email: [sbdmotorsport@btclick.com](mailto:sbdmotorsport@btclick.com)



New from Rowley Race Dynamics

3rd Edition

# An Introduction To Race Car Engineering Book 1



With the help of powerful software packages, this exciting new book provides the race engineer with considerable insight into the possible performance envelopes of a modern race car.



TO ORDER:  
[www.rowleyrace.com](http://www.rowleyrace.com)

**ATL RACING FUEL CELLS**

**PROUD SUPPLIER TO EVERY F1 TEAM!**

PLUS OFFICIAL SUPPLIERS TO:

- > BTCC (BRITISH TOURING CAR CHAMPIONSHIP)
- > STCC (SWEDISH TOURING CAR CHAMPIONSHIP)
- > DTM (DEUTSCHE TOURENWAGEN MASTERS)

**ATL UK**  
Tel: +44 (0)1908 351700  
sales@atltd.com  
www.atltd.com

**ATL USA**  
Tel: +1 201 825 1400  
atl@atline.com  
www.atline.com

## MOTORSPORT QUALITY ROD ENDS AND SPHERICAL BEARINGS



*broadest range in Europe metric and inch sizes*

contacts in English, Deutsch, Français, Italiano

## INTERNATIONAL STOCKING DISTRIBUTORS AURORA® · RODOBAL® · Seals-it®

ACCESSORIES:  
side seals  
protection boots,  
jam-nuts  
bearing installation tools

Getecno srl  
16141 GENOVA - Italy  
fax +39 010 835.66.55  
phone +39 010 835.60.16

[www.getecno.com](http://www.getecno.com) - [info@getecno.com](mailto:info@getecno.com)

## MSA / FIA COMPLIANT FUEL SAMPLING KIT FROM THINKAUTOMOTIVE

As of 2009 the MSA states in its Blue Book (page 150 [C(b)] 19) that cars competing in British + MSA titled championships must have a system built in that is capable of taking a fuel sample. Here at Think Automotive we have a variety of kits available to enable you to comply with both MSA and FIA regulations.

Prices start from:  
**£73.25**



CALL US NOW ON:  
**0208 568 1172**  
OR VISIT:  
[www.thinkauto.com](http://www.thinkauto.com)

**Aeroquip**

**MOCAL**  
Fluid Systems

# CHASE

CHASECAM.CO.UK

# CAM

## THE NEW CHASECAM ONBOARD DATA MODULE IS HERE...



### Your PDR has just got smarter...

The PDR 100 GF solid state digital recorder can now capture both high quality video **AND** record data!

Using our new **Data Module** and **Dashware** software, any PDR can record data from our 10Hz GPS, onboard accelerometers, vehicle sensors and even OBD2. Analyse raw data and view as graphics on the video. Custom graphic packages also available.

See our new products in action on The Ring video, go to the **ChaseCamTV** channel on YouTube or see our website [www.chasecam.co.uk](http://www.chasecam.co.uk) for further details.

[www.chasecam.co.uk](http://www.chasecam.co.uk)  
Tel : 0333 666 0366 or Email : [sales@chasecam.co.uk](mailto:sales@chasecam.co.uk)





# “THERE’S NOTHING LIKE IT!”

**1,100 EXHIBITORS • 3,200 BOOTHS**

MORE THAN A **TRADE SHOW!**

RACE INDUSTRY WEEK 2011:

- Advanced Engineering Technology Conference
- International Council of Motorsport Sciences
- Professional MotorSport Circuit Owners, Investors and Suppliers Forum
- Stock Car Setup Seminar
- Bobby Rahal Young Drivers Symposium
- Vehicle Dynamics & Data Acquisition Seminar



TRADE ONLY • 40,000 BUYERS • 65 COUNTRIES REPRESENTED

**24<sup>TH</sup> Performance  
Racing Industry  
ANNUAL TRADE SHOW**

**DECEMBER 1-3, 2011**  
ORLANDO, FLORIDA • USA  
[www.performanceracing.com](http://www.performanceracing.com)





## John Doonan INTERVIEW



### Q What is Mazda's future in motor racing?

Sylvain Tremblay's SpeedSource has been commissioned by us to carry out a study with regard to how our new production car based SKYACTIV programme can be used in motorsport. This includes the diesel engine architecture SKYACTIV-D. We are looking at GT as well as top level sports car applications of this. The 20th anniversary of Mazda's win at Le Mans has us searching hard for what form of motorsport can serve as a tool to communicate the SKYACTIV message. It would be amazing to come back here and compete with the new SKYACTIV-D diesel technology, but it all comes down to budget and we have always lived within our means.

### Q Are you saying that there might be a diesel Mazda at Le Mans?

There are certain questions you don't have to answer just yet! SpeedSource is looking at areas of motorsport application for both the SKYACTIV-G petrol and SKYACTIV-D diesel initiatives and examining where these particular programmes can lie. SKYACTIV is Mazda's new way of thinking. Rather than adopt hybrid or electric technologies, it is based on small displacement efficient engines, transmissions and more rigid chassis. The

#### Manager, Motorports Team Development at Mazda and MMNAO

- 1988-1992 : Augustana College, BA
- 1992-1997 : Western Illinois University, MBA
- 1993: Development Officer, Augustana College
- 2003: Regional Advertising Manager Mazda North American Operations
- 2005: : Manager, Motorports Team Development, Mazda and MNAO

internal combustion engine is going to be a critical part of the automotive story for decades to come. I believe SKYACTIV can assist our motorsport image in the same way that the rotary engine has done. It will bring the same spirit.

### Q When will SKYACTIV be used for racing??

SKYACTIV technology is being introduced on road cars this year. The latest Mazda3 has elements of SKYACTIV-G with full SKYACTIV-D being introduced next year with new engines, transmissions and body styles. Depending upon the availability of product, it will be late 2012 or early 2013 before any application of SKYACTIV can be announced for racing.

### Q What is the situation in grass roots racing?

According to the SCCA, Mazda currently has a 50 per cent share of grass roots racing in the USA while 8-9,000 customers purchase competition parts from us. The first two generation RX-7s and the Miata have become staples in club racing. Although some of our competitors have withdrawn from running series at this level and car counts are down, we remain focussed on this sector. Our ladder programme also continues to be important as far as image is concerned, introducing younger drivers to the brand and presenting it as an alternative to the more expensive, premium makes. The Mazda Road to Indy and the Mazda Scholarship remain in place for open-wheel and closed car aspirants

### Q What are your short term plans?

We will continue in ALMS and Grand-Am racing for now, at least until the end of the year. Initially, the MZR-R engine had reliability problems, but we and AER have overcome this. The changes in regulations mean that we now compete in LMP1 and the car count is well down. The Grand-Am RX-8 also comes to the end of its life next year. We are, thus, currently assessing what we do in ALMS, Grand-Am and on a bigger scale.

## RACE MOVES

**Steve Nielsen** is to leave the Renault Formula 1 team. Nielsen has been with the team for over 10 years and is under contract until the end of this year, though it's thought he will depart after the Singapore GP at the end of September.

**John Wickham**, who was once the technical and operations manager of the now-defunct A1GP series, has been asked to conduct an efficiency study of the Renault F1 team and he is also expected to take up a position within the organisation. Wickham was the team manager of the Spirit F1 outfit in the early '80s, where he was responsible for bringing Honda back into F1 as an engine supplier in 1983.



John Wickham

**David Higdon** has been named managing director within NASCAR's newly-formed Integrated Marketing Communications department. Higdon joined NASCAR from the LPGA Tour, but has previous motorsport experience working as vice president of strategic development and communications at ChampCar from 2007 until 2008.

**Dale Inman** and **Glen Wood** are amongst the 2012 class of inductees into the NASCAR Hall of Fame. Inman was **Richard Petty's** crew chief at Petty Enterprises for nearly three decades,

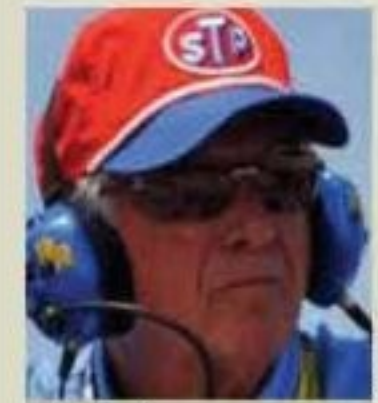

Dale Inman

setting records for the most wins (193) and championships (eight) by a crew chief. Wood is best known for his collaboration with brothers Leonard and Delano at Wood Brothers Racing. The team, which dates back to 1950, has amassed 98 victories. Drivers **Cale Yarborough**, **Darrell Waltrip** and **Richie Evans** complete the line up of new inductees.

**Chad Johnston** has replaced **Pat Tryson** as crew chief for **Martin Truex jr's** no 56 Michael Waltrip Racing Toyota, which competes in the NASCAR Sprint Cup. Johnston was previously lead engineer at MWR, while Tryson had been crew chiefing the Truex car since the start of the 2010 season.

**Bobby Hutchens** has been released from his position as director of competitions at NASCAR outfit, Stewart-Hass



# Formula Student on the Racecar Engineering website

Exclusive, unrivalled coverage of the biggest student motorsport event in the World



- **Breaking News**
- **Every car**
- **Blogs + Data**

[www.racecar-engineering.com/formulastudent](http://www.racecar-engineering.com/formulastudent)



## RACE MOVES



**Leena Gade** became the first female race engineer to win the Le Mans 24 Hours when the Audi R18 she tends crossed the line first at this year's classic encounter. Gade, 35, is from London and is a graduate of the University of Manchester

Racing, as part of a management shake up. Hutchens, who was a fixture at Richard Childress Racing before becoming vice president of competition at Dale Earnhardt Inc in 2008, was among the first to join the Stewart-Haas organisation.

In the same management shake up that saw the departure of **Bobby Hutchens**, **Matt Borland**, a former crew chief who had been the Stewart-Haas technical director, has been promoted to vice president of competition. Borland will also serve as director of competition on an interim basis until that position is filled permanently.

**Rick Viers** is now crew chief on the Rusty Wallace Racing no 62 Toyota that competes in the NASCAR Nationwide

Series. Viers came to RWR after a spell with the Roush Fenway Racing Nationwide team last year, while he was also a crew chief at Red Bull Racing in 2007-'08. Meanwhile, former no 62 crew chief, **Jason Overstreet**, will now take on the role of car chief for RWR's no 64 Toyota.

**Stephen Charsley** has been appointed Lola's vice-president for North America. Charsley has been Lola's manager in North America since 2008, while before joining the company he had F1 experience with Arrows and Brabham. He has also worked in Group C and NASCAR.

**Richard Childress** has been fined \$150,000 by NASCAR after the team owner was involved in an altercation with **Kyle Busch** after the truck race at Kansas. Childress has also been placed on probation until the end of the season.

**Gary Frost**, who is a crew member on the no 31 Richard Childress Racing entry in the NASCAR Sprint Cup Series, has fallen foul of the governing body's strict substance abuse policy. Frost has been indefinitely suspended from all NASCAR competition.

Team Lotus boss and Air Asia Group CEO, **Tony Fernandes**,

## James Gornall INTERVIEW



### Q Formula 2 is into its third season now, how's it been doing?

Very good. Obviously this is a very difficult time to be running any championship. With it being a new championship [in 2009] we came in with a bang, but other championships have also come in with a bang since, and so we got the limelight for a short time, but we have continued to improve. We've got good grid numbers, and you can see all across the world that grid numbers are struggling, so we're doing well.

### Q Where exactly is F2 in relation to other championships?

We don't have a car that's as quick as a GP2, but we also don't charge a million and half euros for a season [F2 is £225,000]. World Series by Renault is a good championship, but that's also three times as expensive as F2, even if you can go a couple of seconds quicker - though we've proven to be as quick on certain circuits as that car.

As for GP3, that's a junior formula. We are offering something quicker, and we would like to go quicker still, we're always developing the car. It came out so quickly in 2009 that the car wasn't developed to its full potential straight away. We improved

it a lot for the 2010 season and we're still improving it, but the whole idea of the championship is to keep it cost effective. Now, we could make it quicker by throwing lots of money at it, but then we would have to put the price up which is not what the drivers want. So we're looking for a nice balance.

### Q Many championships are now going down the turbocharger route; do you think F2 was a bit ahead of the game in this respect?

I think so. Everything seems to be going turbocharged. It's all about efficiency, isn't it? Running a small capacity engine and boosting it with a turbocharger is going in the right direction, they're talking about it in Formula 1 and it's in World Touring Car and British Touring Car, so it's all coming towards where we are, because they're looking at being a little greener and they're looking to reduce costs. We went in with that aim all along.

### Q The VAG 1.8T is quite an old engine now though, isn't it?

Well, it's one that's tried and tested. We used it in the Formula Palmer Audi Championship in previous years, so we knew exactly what it could do. But then again this engine's completely different, it might look the same on the outside, the same block, but the internals and the turbocharger are completely different. We work with Moutune and we have got a lot out of it. They don't need rebuilding during a season - they do an entire season comfortably - so that saves a lot of money.

### Q The championship is run centrally without teams, so how do you allocate race engineers?

It's not an engineer for each driver. We pool the resources, and this brings the cost down. There are three drivers to every one engineer, with ample time for each driver to do what he needs to do. We do actually, in the interests of fairness and equality,

### FIA Formula Two championship coordinator

- 1995-2002: karting
- 2003: BARC Formula Renault Champion
- 2003-2006: Oxford Brookes University studying business management; also involved in Formula Student, driving the car and working on marketing
- 2006: joined Motor Sport Vision as race driving instructor, eventually becoming 'Super Senior' instructor
- 2008: British GT champion
- 2009: took position as F2 championship coordinator at end of season



# Get Racecar Engineering direct to your computer

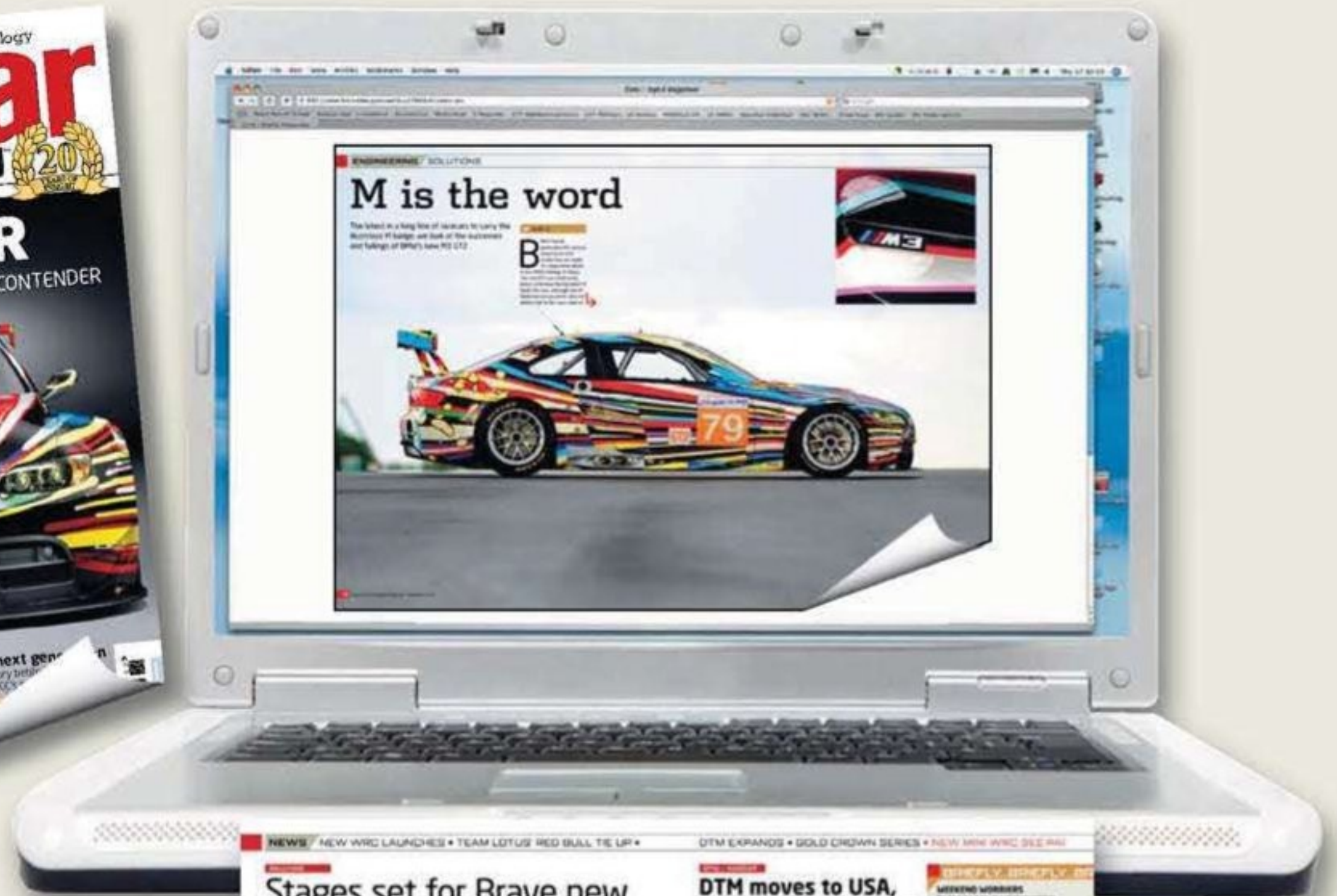

## THE WORLD'S LEADING MOTORSPORT TECHNOLOGY PUBLICATION

Each month **Racecar Engineering** brings the best possible insight into all forms of the rapidly changing world of motorsport engineering.

From keeping pace with the latest technologies to expanding your knowledge of racecar design and operation, no other magazine gets you closer.



Go to [www.racecar-engineering.com/digital](http://www.racecar-engineering.com/digital) to get a sneak preview and see the latest great offers



## RACE MOVES

has been awarded with the Panglima Setia Mahkota, one of Malaysia's highest honours. The award is given to 'distinguished citizens who have given meritorious service to Malaysia' and there are only 250 recipients of the title at any given time. It's been a good year for Fernandes where gongs are concerned, as he's also received a CBE from the Queen and the title of Officier of the Legion d'honneur from the French Government.

**Jenni Alexander** has returned to Delta Composites to take on the position of supply chain controller. She formerly joined the company in 2008 from Red Bull Technology to work as production coordinator, but left in 2009 to expand her career in supply chain management.

**Anna Rees** is another new addition to the Delta Composites supply chain team. Rees has previous experience in credit control, accounting and banking and her role will involve direct liaison between customers and production planning. Meanwhile, as part of an ongoing expansion of the business, Delta Composites has also

taken on five new trainee laminators.

The MSA's Go Motorsport initiative has appointed rally co-driver, **Howard Davies**, as its regional development officer for the North Wales area. Davies won the 1996 British Rally Championship as a co-driver alongside Gwyndaf Evans, and now presents the Welsh language *Ralio* TV programme for S4C.



Aldo Costa

**Aldo Costa** has stepped down as technical director at Ferrari while the Scuderia has also announced a new structure for the technical team. **Pat Fry** is taking on the role of director of the chassis side (technical director in all but name), while production will be in the hands of **Corrado Lanzone**. **Luca Marmorini** will continue to be in charge of the engine and electronics departments and all will report directly to team principal **Stefano Domenicali**.

■ Moving to a great new job in motorsport and want the world to know about it? Or has your motorsport company recently taken on an exciting new prospect? Then send an email with all the relevant information to Mike Breslin at [bresmedia@hotmail.com](mailto:bresmedia@hotmail.com)

## James Gornall INTERVIEW

CONTINUED

rotate the engineers, but all of our engineers are extremely experienced, they all know the car very well, and there's nothing to stop any driver going and talking to any of the other engineers, or in fact our chief engineer, James Goodfield. So while you have one engineer for three drivers, you actually have many, many engineers you can go and talk to for a second opinion if you want to.

### Q There's talk of 'ghost engineers' in F2, too, what exactly is a ghost engineer?

Well, we don't stop anyone bringing a friend along and if your friend happens to be Paddy Shovlin, then that's fine! Ultimately the driver has the final say on the set-up and he can bring an engineer with him and we will let them get involved. We call these ghost engineers. However, there are certain rules. People outside of Formula 2 aren't allowed to touch the cars, everything goes through our engineers, and during a session only our own F2 personnel are allowed to talk to the drivers.

Before we go to any event James Goodfield will produce our recommended baseline set-up. Drivers can alter that

if they want. But you can probably just leave it in that set-up and go and win the race.

### Q How do you ensure parity between the cars?

One of the key points of Formula 2 is that we share data, so every single time the cars go out on the track the data of the fastest lap - as well as the video because we have onboard cameras with data overlay - can be seen by every single driver on the grid. You can see everything, including the boost pressure that the engine is creating. It's all very transparent, and there's no argument. Sometimes people think they might not have the same amount of power, but they look at the data and they can see that actually it's creating the same boost, there's no problem, and they go out the next session and try a different line and Bob's your uncle, they're just as fast.

### Q What's the future for F2?

We obviously want to see some Formula 1 drivers come out of Formula 2, and we will be taking steps into making the car faster, but everything we do will have the cost in mind.

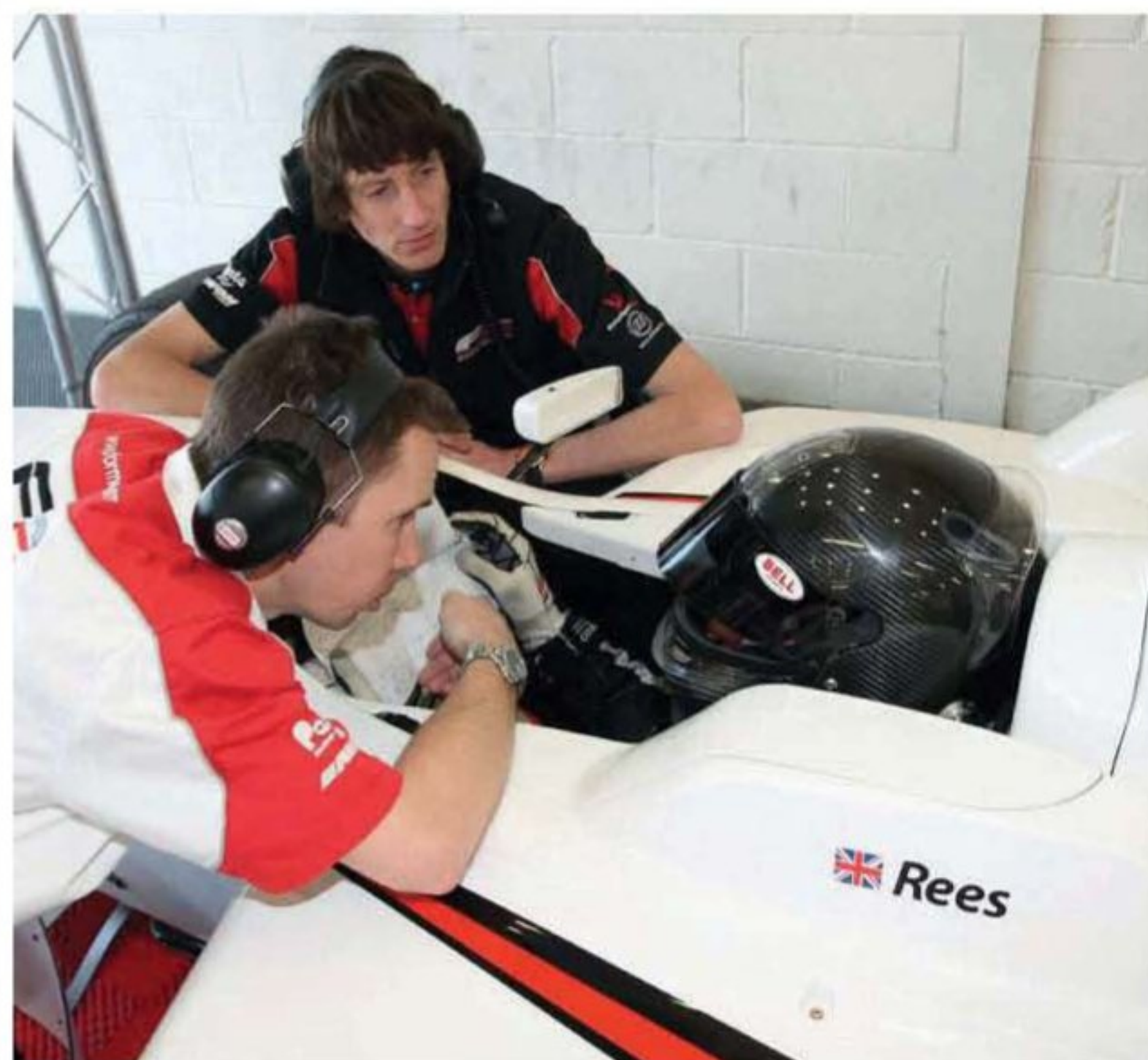



## PIT CREW

**Editor**

Andrew Cotton

**Deputy Editor**

Sam Collins

**News Editor**

Mike Breslin

**Design**

Dave Oswald

**Chief Sub Editor**

Mike Pye

**Staff Writer**

Lawrence Butcher

**Contributing Editors**

Paul Van Valkenburgh

**Technical Consultant**

Peter Wright

**Contributors**

George Bolt jr, Alan Lis, Ralph Koyess, Simon McBeath, Danny Nowlan, Mark Ortiz, Paul Truswell, Ian Wagstaff, Paul J Weighell

**Photography**

LAT, Gavin D Ireland

**Group Sales Director**

Steve Ross

Tel +44 (0) 20 7349 3161

Email [steve.ross@chelseamagazines.com](mailto:steve.ross@chelseamagazines.com)**Head of Business Development**

Tony Tobias

Tel +44 (0) 20 7349 3176

Email [tony.tobias@chelseamagazines.com](mailto:tony.tobias@chelseamagazines.com)**Senior Ad Sales Executive**

Lauren Mills

Tel +44 (0) 20 7349 3186

Email [lauren.mills@chelseamagazines.com](mailto:lauren.mills@chelseamagazines.com)**Publisher**

Luke Bilton

**Senior Publisher**

Sarah Arthur

**Managing Director**

Paul Dobson

**Editorial**

Racecar Engineering, Chelsea

Magazine Company,

Suite 19 Chelsea Wharf,

15 Lots Road,

London SW10 0QJ UK

Tel +44 (0) 20 7349 1920

**Advertising**

Racecar Engineering, Chelsea

Magazine Company,

26-30 Old Church Street,

Chelsea, London SW3 5BY UK

Tel +44 (0) 20 7349 3150

Fax +44 (0) 20 7349 3160

**Worldwide Subscriptions**

CDS, Tower House, Sovereign Park,

Market Harborough,

Leics LE16 9EF UK

Tel +44 (0) 1858 438749

Fax: +44 (0) 1858 434958

**Subscription Rates**

UK £72 (12 issues)

USA \$135 (12 issues)

ROW £84 (12 issues)

**News Distribution**

COMAG, Tavistock Road, West

Drayton, Middx UB7 7QE

**Printed by**

Wyndeham Heron

**Printed in England**

ISSN No 0961-1096

USPS No 007-969

[www.racecar-engineering.com](http://www.racecar-engineering.com)

## BUMP STOP

# Tomorrow, the World...

It was what the commentators, teams and manufacturers had been waiting for, but when the news was confirmed at Le Mans that there would, indeed, be a World Endurance Championship, the questions immediately started. Why had the ACO handed over its crown jewels? What was in it for them? Was endurance racing a pawn in the game of chess that Jean Todt is playing with Bernie? Was the ACO so naïve as to believe that it had done well out of this deal? What would happen to the Le Mans Series and the ALMS? What made matters worse was that neither the ACO nor the FIA was answering the questions. 'It will be sorted out', they said, and that raised suspicions further.

The deal is for three years, with an option to extend a further 10 in 2014. The World Endurance Series will comprise six races, plus the Le Mans 24 Hours. In the first year, it will follow the same calendar as the Intercontinental Le Mans Cup and, after that, there will be two races in the US, two in Europe and two in the Far East.

That immediately set the heckles up at Peugeot, which has in the past gone on record to say that they would block a race in Japan in favour of one in Brazil. The commercial promotion of the Championship will be run by the Le Mans Endurance Series Management Company, of which the ACO has the majority holding, while the ACO will retain legal, commercial and financial autonomy over the Le Mans 24 Hours.

The FIA will get its fingers into the pie on technical regulations - a move that delighted Aston Martin Racing chairman, David Richards, who says that the balance of performance will now lose its commercial element. The FIA will set up a technical working group, and will share equal representation on it with the ACO, along with manufacturers and private teams. Their proposals will then go to the World Motor Sport Council for final approval, as they do with Formula 1 and the World Rally and Touring Car Championships. But commentators are worried about this. The ACO has given up autonomous control of its regulations. Why?

The ACO says that the 'World' title will make it easier

to sell to television and to raise advertising. A World title is what the manufacturers want, and now the ACO has it, it must guarantee two LMP constructors, and three in 2014, as well as four GT Endurance constructors.

In return, the deal has given the FIA substantial amounts of money, particularly in sportscar terms. In real terms, the FIA is looking to make 1.152million Euros out of the entry fees, calendar fees, regulatory fees and homologation fees, less than half of what the ACO will make from the same criteria. The FIA's share will rise to 1.5m Euros in year two, and more than 2.2m Euros in 2014, based on an entry of 26 cars.

The money is useful, and the FIA needs it, but Todt will have political pressure coming down on his

shoulders to promote green technology, as well as road safety. He is already warring with teams in Formula 1, trying to push through 1.6-litre engine regulations, but manufacturers have turned their back on F1, and Renault's future hangs in the

balance. So fast is the saga moving that, by the time this is published, it will all be decided, one way or the other.

Todt now has a new platform, a place to offer manufacturers who want to test technology in racing conditions. He can satisfy those who require his FIA organisation to promote alternative drivetrain technology, and can count on an income from what could be a prosperous series.

But what has he had to give up to achieve this? The ACO says that this is a contract like no other the FIA has ever signed, and that Todt has an interest in Le Mans, having won it with Peugeot in 1992 and 1993. Jean-Claude Plassart, President of the ACO, was once in charge of the French supermarket chain Carrefour, so is clearly one who knows how to write a contract.

The ACO may have given up autonomy, and privately officials admitted that the deal could still go pear shaped but, as Todt was whisked back to Paris, the ACO walked their paddock looking extremely happy.

**EDITOR**

Andrew Cotton

the 'World' title will make it easier to sell to television and to raise advertising

For subscription queries or to buy *Racecar Engineering*, go to  
<http://www.subscription.co.uk/racecar/> or [racecarengineering@subscription.co.uk](mailto:racecarengineering@subscription.co.uk)  
 telephone 0844 243 0778 +44 1858 438443 (overseas)

• *Racecar Engineering*, incorporating *Cars & Car Conversions* and *Rallysport*, is published 12 times per annum and is available on subscription. Although due care has been taken to ensure that the content of this publication is accurate and up-to-date, the publisher can accept no liability for errors and omissions. Unless otherwise stated, this publication has not tested products or services that are described herein, and their inclusion does not imply any form of endorsement. By accepting advertisements in this publication, the publisher does not warrant their accuracy, nor accept responsibility for their contents. The publisher welcomes unsolicited manuscripts and illustrations but can accept no liability for their safe return. © 2011 Chelsea Magazine Company. All rights reserved.

• Reproduction (in whole or in part) of any text, photograph or illustration contained in this publication without the written permission of the publisher is strictly prohibited. *Racecar Engineering* (USPS 007-969) is published 12 times per year by Chelsea Magazine Company in England.



# Made for winners!



*max-line*



- Coilovers in 3 dampening variants
- Max. technical lowering
- With german TÜV-certificate



- Optimum performance on the race track
- With adjustable top mounts
- For the race track and the road



- Motorsport suspension for top-level motorsport
- 2- and 3-way adjustable
- Numerous motorsport successes



KW automotive GmbH  
Phone: +49 7971 9630-0  
[www.KWsuspensions.de](http://www.KWsuspensions.de)



KW automotive North America, Inc.  
Phone: +1 888 721 3888  
[www.KWsuspensions.com](http://www.KWsuspensions.com)



KW automotive UK Ltd  
Phone: +44 870 990 7536  
[www.KWautomotive.co.uk](http://www.KWautomotive.co.uk)



WHAT'S IT FEEL LIKE ON THE  
OTHER SIDE OF THE FENCE?



FIND OUT.

NEW!  
Visit our  
facebook shop!



PERFORMANCE<sup>®</sup>  
FRICTION  
BRAKES